

(19)



(11)

**EP 3 076 418 B1**

(12)

**EUROPEAN PATENT SPECIFICATION**

(45) Date of publication and mention of the grant of the patent:  
**19.07.2017 Bulletin 2017/29**

(51) Int Cl.:  
**H01H 9/16 (2006.01) H01H 19/02 (2006.01)**  
**H01H 9/18 (2006.01)**

(21) Application number: **15382167.3**

(22) Date of filing: **01.04.2015**

**(54) LIGHT-SIGNALLING SYSTEM FOR ELECTRIC CONTROL AND COMMAND DEVICES**

LICHTSIGNALSYSTEM FÜR ELEKTRISCHE STEUERUNG- UND BEFEHLSVORRICHTUNGEN  
 SYSTÈME DE SIGNALISATION LUMINEUSE POUR DISPOSITIFS DE CONTRÔLE ET DE  
 COMMANDE ÉLECTRIQUES

(84) Designated Contracting States:  
**AL AT BE BG CH CY CZ DE DK EE ES FI FR GB  
 GR HR HU IE IS IT LI LT LU LV MC MK MT NL NO  
 PL PT RO RS SE SI SK SM TR**

(43) Date of publication of application:  
**05.10.2016 Bulletin 2016/40**

(73) Proprietor: **Gave Electro. S.L**  
**08430- La Roca del Vallès (ES)**

(72) Inventors:  
 • **Carrión Soriano, Sebastián**  
**08430 LA ROCA DEL VALLES (ES)**

• **Perez Cano, Baldomero**  
**08430 LA ROCA DEL VALLES (ES)**

(74) Representative: **Oficina Ponti, SLP**  
**C. de Consell de Cent 322**  
**08007 Barcelona (ES)**

(56) References cited:  
**WO-A1-2010/071922 DE-A1-102008 035 458**  
**US-A- 5 710 544 US-A1- 2005 155 159**  
**US-A1- 2011 030 609**

**EP 3 076 418 B1**

Note: Within nine months of the publication of the mention of the grant of the European patent in the European Patent Bulletin, any person may give notice to the European Patent Office of opposition to that patent, in accordance with the Implementing Regulations. Notice of opposition shall not be deemed to have been filed until the opposition fee has been paid. (Art. 99(1) European Patent Convention).

## Description

### Object of the Invention.

**[0001]** This invention consists in a light-signalling system built into switches to show the position and/or status of the installation, machine or circuit they control.

### State of the Art:

**[0002]** There are and have been different types of control switches on the market that have an illumination module and which can therefore be considered state of the art with regard to the invention.

**[0003]** These control switches govern other main power switches, using lights to identify the status of the circuits by means of lighting systems.

**[0004]** This solution for viewing the control of other switches makes integration of a light module in a circuit switch costly and complex.

**[0005]** In addition, current solutions to see the status of elements of machines in the circuit controlled by the switch normally required the use of a column with different light indicators so as to view the operating parameters of the installation, machine or circuit, resulting costly and complex to install. In addition, current systems to see the status of switches (On or Off) required the installation of pilot lights with the resulting installation cost and the need to be in the proximity in order to see their status (On or Off).

**[0006]** The document DE 10 2008 035458 A1 discloses an operation panel for an air-condition system in a vehicle (see figures 1, 2A, 2B) with control elements 4, 5 for an user input for adjustable air-conditioning functions and elements 6, 7 for visual indication of the function selection and the setpoint and/or actual value of the selected function. A control circuit 3 is connected to and receives user input via the control elements 4, 5 and to is connected and generates output to the elements 6, 7 for visual indication, such that the displayed visual indication is associated with the state of the control elements.

**[0007]** The document US 2005/155159 A1 relates to an appliance controller for a washing machine comprising a main controller module with an user cycle selector (see e.g. figure 28), wherein the user cycle selector is rotated by the user in order to select a particular operating cycle of the washing machine (i.e. a selected appliance cycle). During rotation of the user cycle selector, individual LEDs 307 are alternately lit depending on and in accordance with the direction of rotation of the user cycle selector and the speed of rotation. The processor 60 generates position signals for the individual LEDs 307 depending on the direction of rotation of the user cycle selector and the rate of rotation. The position signals are used to light and turn off the appropriate LEDs. As the user cycle selector is rotated, the appropriate or next LED is lit while the previously lit LED is turned off. Once a desired cycle or position within a cycle is selected (i.e.

the appropriate LED is lit), the user puts the washing machine into the cycle operation mode by pushing the control knob inwardly toward the overlay 388.

**[0008]** The document US 5 710 544 A relates to an operation state display apparatus and a displaying method thereof capable of displaying an operation state of an electric appliance with a shuttle switch and providing a more fashionable product by providing an improved display unit, which includes a shuttle switch for producing a certain code signal in accordance with its turn in leftward direction or rightward directions; a microprocessor for recognizing a code signal outputted from the shuttle switch, for outputting a control signal corresponding to the thusly recognized code signal, and for controlling a control object; and a display unit enabled by a control signal outputted from the microprocessor for displaying an operation state of the control object in accordance with an operation of the shuttle switch.

### 20 Scope of the Invention:

**[0009]** This invention aims to provide a light-signalling system, suitable for combination with a switch, corresponding to a control with fitted lights, which by using signals that are external or internal to the command-switch assembly, make changes in the lighting mode according to programmed parameters, so that it is possible to signal either the position of the control, status of the installation, machine or circuit, or both options at once and in a simple and economic manner.

### Description of the Invention:

**[0010]** This invention is materialised in a light-signalling system that can be fitted to switches with an illuminated control device that carries out a change in lighting according to the signals captured internally or received from outside, according to the configuration of the module that governs the parameters for the changes of this type of lighting. As said above, these signals can be internal, such as the detection of the functional position of said control, and/or external signals such as the impulses generated by elements that indicate the status of elements in the installation, machine or circuit it is connected to.

**[0011]** For each of these states and/or positions, a certain lighting mode is established, either no lighting, lit in a certain colour, flashing or even acoustic devices can be fitted to add sound to the signals received.

**[0012]** The light-signalling system is fitted to the switch with means to disconnect it in case of maintenance.

**[0013]** The light-signalling system has a system for changing the lighting mode, which receives at least one signal from components external or internal to the light-signalling system and the switch, connected to said lighting changing system, which, according to the programming of its electronic circuits, will implement a certain type of lighting. This connection can be direct for internal signals or through a module connection terminal strip for

external signals.

**[0014]** Each of the signals in the lighting mode change system is associated to a certain lighting mode, according to the needs of the installation, machine or circuit, the change in lighting mode happens automatically whenever there is a signal. These changes can be switching on or off the lighting, changing the colour of the light, flashing the light or even changing colour while flashing, as well as acoustic signals.

**[0015]** Configuration of lighting modes governed by the lighting mode change system is carried out according to the user's criteria, and the lighting mode assigned to each of the signals received by the system can be changed according to needs. This configuration is carried out by programming the electronic circuit in the lighting mode change system.

**[0016]** If the signal connected to the lighting mode change system is internal, this signal will preferably correspond to the signal generated by the means to detect the position of the control, therefore, according to its position, these means for detecting position will send a signal that will depend on the position, so that when the lighting mode change system receives the signal, it will change the lighting to the pre-established configuration for this new position.

**[0017]** If one or more external signals are connected to the lighting mode change system, they will connect preferably through an exterior terminal strip, with the elements that act as controllers of the status of the installation, machine or circuit, such as PLCs, thermocouples or any other element generating a sustained electrical impulse, so as to indicate the status, excess temperature, status of a motor connected to a circuit, etc., several of them can be connected to the lighting mode change system, each of them having preferably an input on the terminal strip, and for each signal received from each of them, the lighting mode change system has an assigned lighting mode, by programming the electronic circuit. The external terminal strip will have as many connections as signals are to be received in the lighting mode change system.

**[0018]** The lighting mode change system can in turn have at least one internal signal connection corresponding to the means for detecting the position of the control, and at least one connection to components external to the switch and the light-signalling system. These lighting modes can be accompanied by an acoustic effect produced by means built into the lighting module, as a complement to the illuminated signals.

**[0019]** The configuration of the lighting mode change system can be reprogrammed to change the association of each of the inputs of the external or internal signals to the assigned lighting mode.

**[0020]** In this manner we have the light-signalling system comprising a casing that contains means to attach to the switch, with a control that enables the lighting mode produced by the interior lighting devices to be viewed, governed by at least one system to change the lighting

mode that has at least one signal input, which can be either internal and/or external to the switch and the light-signalling system. This enables the user to have information on the status of the installation, machine or circuit where it is installed in a simple and economic manner, configuring the lighting modes emitted by the light-signalling system according to the user's specifications and replacing complex and costly systems with columns of light signals or pilot light installations.

**[0021]** This system is made as a modular system, in which the light-signalling system is designed to fit to different standard switches, although this needs the incorporation of an extension of the control shaft to attach to the movement with the switch shaft.

**[0022]** Thanks to its modular nature, there is a possibility of wiring the lighting module, outside an electrical switch, lighting the desired signal in the final installation of the equipment.

**[0023]** The switch control is preferably made of material that lets light through it, normally plastic, to allow the installation of means to generate light inside the module, and which can be transmitted by means of the control, lighting up the control for each of its positions. Other solutions are possible, as long as this lighting is provided and the changes in lighting mode can be seen by the user.

**[0024]** The means for lighting are preferably LEDs located in their specific housing. The LEDs are fitted in such a manner to ensure that the failure of one of them will not affect the safety of the installation or the failure of the module itself, falsifying the visual information provided by the device, so there are several series of parallel LEDs, so that in case of a failure, the module will still light up. This considerably increases the life of the device and its safety in comparison to current devices.

**[0025]** The switch control for that the light-signalling system is suitable to be incorporated into may incorporate means to carry out physical locking of the position by means of a padlock or similar element, to insure that the control position cannot be altered.

**[0026]** The operating procedure incorporated into the light-signalling system for switches, is based on its connection in the installation, machine or circuit, so that the system for changing the lighting mode will execute actions on the lights. The different functional positions of the control, corresponding to the physical positions, are assigned a specific lighting mode and they are the means to detect the position of the control, and/or the impulses of the elements of the circuit that register its status, those that act sending signals about the lighting mode change module.

**[0027]** In this manner and according to the aforementioned characteristics, from a functional point of view the inherent advantages of attaching the present light-signalling system to a switch, with the aforementioned resources, are the following:

- Reduction of build complexity and cost of the system.
- Information on the position of the switch, replacing

- conventional pilot lights.
- Information on the status of the installation, machine or circuit and its components in a single light indicator, replacing more complex columns of indicators.
- System directly detecting the position so that failure of interpretation due to early change of the manoeuvre can be avoided.
- A much greater life cycle for the product, by introducing LEDs as a lighting element.
- Simple maintenance: can be exchanged for other similar systems easily.

#### Description of the drawings.

#### **[0028]**

Figure 1 is a perspective view of the switch with the light-signalling system fitted.

Figure 2 is a perspective view of the light-signalling system detached and without the control or the switch shaft.

Figure 3 is a composition/operation diagram of the lighting mode change system with internal signal inputs.

Figure 4 is a composition/operation diagram of the lighting mode change system with external signal inputs.

Figure 5 is a composition/operation diagram of the lighting mode change system with external and internal signal inputs.

#### Description of the invention.

**[0029]** In the invention, as can be seen in Figures 1 and 2, the light-signalling system (10) is fitted to a switch (11), which executes the operations carried out by the control (12).

**[0030]** The light-signalling system (10) has means for attachment (15), normally fasteners, allowing it to be detached from the switch (11) for maintenance or replacement. To attach it, the switch shaft must coincide with the control shaft (12) of the light-signalling system (10), as well as with the rest of elements depend on each other.

**[0031]** The light-signalling system (10) comprises a casing (20) made of plastic material or the like, covering the elements inside the system (10).

**[0032]** One of its sides houses the control (12) that operates the switch (11) functions. This control (12) is formed by a component that in this embodiment is triangular in section, although other shapes are possible, where the inner and outer faces of the control (12) are made in such a way that they are translucent, so that light emitted by the series of LEDs (18) that act as means of lighting can be clearly seen and which are in the housing (19).

**[0033]** The series of LEDs (18) are housed (19) inside the casing (20), in areas where the light can be transmitted to the control (12). The LEDs (18) are commonly dis-

tributed so that they form different series of several LEDs (18), these series are placed in parallel, providing extended service life to the module (10) and guaranteeing correct operation.

**[0034]** These series of LEDs (18) are powered and governed by the lighting mode change system (13), which has an electronic circuit (14) that receives the signals, which in this first embodiment (as shown in Figure 3) are only internal to the switch (11) and light-signalling assembly (10), such as the signals received by the means (22) for detecting the control position, which correspond to sensors strategically placed in the operating positions of the control (12), which emit a sustained electrical impulse when the control is positioned over a strategic position of the detecting sensor, such as for example those carried out by the magnetic sensors. These signals of each of the positions of the control (12) activate the lighting change system (13), the lighting modes programmed in the circuit (14), activating the LEDs (18) with a certain colour, turning off the lights, flashing and/or producing a sound with the sound creation resources (23).

**[0035]** In a second embodiment of the invention, as shown in Figure 4, the system for changing the lighting mode (13) stems from an aerial connection (21) by means of a terminal strip, that is connected to the circuit (14), and to these connections (21) of the terminal strip the components (24) of the installation that control or enable the user to know the status of the installation, such as PLCs, thermocouples, or any other element generating a sustained electrical impulse are connected, indicating the status, excessive temperature, the state of a motor connected to the circuit, lack of power of any component, etc.

**[0036]** The moment a signal is received from one of the inputs of the connection (21), the circuit (14) is programmed to execute a specific lighting mode in the LEDs (18), which on receiving another signal, will change to this new mode of lighting. Like in the first embodiment, a sound can be produced from the sound production devices (23). This associates the type of signal, its input, and the programming of changes in lighting mode.

**[0037]** Finally, in a third embodiment of the invention, as can be seen in Figure 5, the lighting mode change system incorporates internal and external signals, the external ones coming from the connection (21) through the terminals strip to which the components (24) of the installation are connected, detectors (22) of control (12) position are also connected to the circuit (14). Its operation, similar to the previous, allows the functions of the previous two embodiments to be integrated into a single one, where it is possible to grant signalling priorities to internal signals or vice versa, associating different lighting modes (colours, absence of lighting, flashing and/or sounds) to each of these signals.

**[0038]** Like the previous claims, the electronic circuit (14) can be designed to operate connected to a DC or AC circuit.

**[0039]** The switch (11) incorporates means for the

physical locking (16) of the position of the control (12), by means of padlocks or similar devices.

## Claims

1. **LIGHT-SIGNALLING SYSTEM FOR SWITCHES**, wherein the light-signalling system (10) comprises a control (12) that operates the switch functions, means of lighting (18) that can light up the control (12), at least one system for changing the lighting mode (13), that executes this change in the means for lighting (18) according to signals or impulses received and a programmable electronic circuit (14), where this lighting mode change system (13) has at least one signal input, received from components external or internal to the light-signalling system (10), where the signal input is connected to a programmable electronic circuit (14) comprising lighting modes associated to each signal,  
**characterised in that**  
the light-signalling system (10) comprises a casing (20) that contains means (15) for attaching to or detaching from a switch, and  
the light-signalling system (10) is designed to fit to different standard switches by incorporation of an extension of the control shaft of the light-signalling system (10) suitable for attaching to the movement with the shaft of the switch.
2. **LIGHT-SIGNALLING SYSTEM FOR SWITCHES** according to the claim 1, **characterised in that** the light-signalling system (10) comprises means (22) for detecting the position of the control (12) and that the lighting mode change system (13) has at least one internal signal connection configured to receive signals from means (22) for detecting the position of the control (12).
3. **LIGHT-SIGNALLING SYSTEM FOR SWITCHES** according to the claim 1, **characterised in that** the lighting mode change system (13) has at least one connection to external components to the switch (11) and the light-signalling system (10), and which indicate installation status parameters by means of an external signal that reaches the electronic circuit (14) of the lighting mode change system (13) through this connection.
4. **LIGHT-SIGNALLING SYSTEM FOR SWITCHES** according to the claim 3, **characterised in that** the lighting mode change system (13), has an external terminal strip for connecting external components (24) to the light-signalling system (10), with as many connections as signals are to be received.
5. **LIGHT-SIGNALLING SYSTEM FOR SWITCHES** according to the claim 1, **characterised in that** the

lighting mode change system (13) has in turn at least one connection configured to receive internal signals from means for detecting the position of the control, and also at least one connection to external components to the switch (11) and the light-signalling system (10), and which indicate installation status parameters by means of an external signal that reaches the electronic circuit (14) of the lighting mode change system (13) through this connection.

6. **LIGHT-SIGNALLING SYSTEM FOR SWITCHES** according to the claim 1, **characterised in that** the lighting mode change system (13) executes the mode of lighting in the lights by establishing a certain colour, absence of colour and flashing of the chosen colour, all configured in the programmable electronic circuit (14), according to the signal received and the input received.
7. **LIGHT-SIGNALLING SYSTEM FOR SWITCHES** according to the claim 2, **characterised in that** the means (22) for detecting the position of the control (12) are sensors that emit electrical signals when the control (12) is located over them.
8. **LIGHT-SIGNALLING SYSTEM FOR SWITCHES** according to the claim 1, **characterised in that** the light-signalling system (10) has means for creating sounds, connected to the electronic circuit (14) of the lighting mode change system (13).
9. **LIGHT-SIGNALLING SYSTEM FOR SWITCHES** according to the claim 1, **characterised in that** the light-signalling system (10) has a locking system (16) of the control (12) position.
10. **LIGHT-SIGNALLING SYSTEM FOR SWITCHES** according to the claim 1, **characterised in that** the light-signalling system (10) has two or more series of LEDs to provide lighting, placed in parallel.
11. **LIGHT-SIGNALLING SYSTEM FOR SWITCHES** according to the claim 7, **characterised in that** the sensors emitting electrical signals when the control (12) is located over them, are magnetic sensors.

## Patentansprüche

1. Lichtsignalisierungssystem für Schalter, wobei das Lichtsignalisierungssystem (10) eine Steuerung (12), die die Schalterfunktionen betätigt, eine Einrichtung zum Beleuchten (18), die die Steuerung (12) beleuchten kann, zumindest ein System zum Verändern des Beleuchtungsmodus (13), das diese Veränderung an der Einrichtung zum Beleuchten (18) gemäß empfangenen Signalen oder Impulsen ausführt, sowie eine programmierbare elektronische

Schaltung (14) aufweist, wobei dieses Beleuchtungsmodusveränderungssystem (13) zumindest einen Signaleingang aufweist, der von Komponenten außerhalb oder innerhalb des Lichtsignalisierungssystems (10) empfangen wird, wobei der Signaleingang mit einer programmierbaren elektronischen Schaltung (14) verbunden ist, die Beleuchtungsmodi aufweist, die jedem Signal zugeordnet sind,

**dadurch gekennzeichnet, dass:**

das Lichtsignalisierungssystem (10) ein Gehäuse (20) aufweist, das eine Einrichtung (15) zum Anbringen an oder Lösen von einem Schalter beinhaltet, und

das Lichtsignalisierungssystem (10) entworfen ist, um durch Eingliedern einer Erweiterung der Steuerungswelle des Lichtsignalisierungssystems (10), die geeignet zum Anbringen ist, mit der Bewegung mit der Welle des Schalters zu unterschiedlichen Standardschaltern zu passen.

2. Lichtsignalisierungssystem für Schalter gemäß Anspruch 1, das **dadurch gekennzeichnet ist, dass** das Lichtsignalisierungssystem (10) eine Einrichtung (22) zum Erfassen der Position der Steuerung (12) aufweist, und dadurch, dass das Beleuchtungsmodusveränderungssystem (13) zumindest eine interne Signalverbindung aufweist, die ausgebildet ist, um Signale von der Einrichtung (22) zum Erfassen der Position der Steuerung (12) zu empfangen.
3. Lichtsignalisierungssystem für Schalter gemäß Anspruch 1, das **dadurch gekennzeichnet ist, dass** das Beleuchtungsmodusveränderungssystem (13) zumindest eine Verbindung zu externen Komponenten zu dem Schalter (11) und dem Lichtsignalisierungssystem (10) aufweist, und die Einbaustatusparameter mittels eines externen Signals anzeigen, das die elektronische Schaltung (14) des Beleuchtungsmodusveränderungssystems (13) durch diese Verbindung erreicht.
4. Lichtsignalisierungssystem für Schalter gemäß Anspruch 3, das **dadurch gekennzeichnet ist, dass** das Beleuchtungsmodusveränderungssystem (13) einen externen Anschlussstreifen zum Verbinden externer Komponenten (24) mit dem Lichtsignalisierungssystem (10) aufweist, und zwar mit so vielen Verbindungen, wie Signale empfangen werden sollen.
5. Lichtsignalisierungssystem für Schalter gemäß Anspruch 1, das **dadurch gekennzeichnet ist, dass** das Beleuchtungsmodusveränderungssystem (13) wiederum zumindest eine Verbindung, die ausgebildet ist, um interne Signale von der Einrichtung zum

Erfassen der Position der Steuerung zu empfangen, und außerdem zumindest eine Verbindung zu externen Komponenten zu dem Schalter (11) und dem Lichtsignalisierungssystem (10) aufweist, und die Einbaustatusparameter mittels eines externen Signals anzeigen, das die elektronische Schaltung (14) des Beleuchtungsmodusveränderungssystems (13) durch diese Verbindung erreicht.

6. Lichtsignalisierungssystem für Schalter gemäß Anspruch 1, das **dadurch gekennzeichnet ist, dass** das Beleuchtungsmodusveränderungssystem (13) den Beleuchtungsmodus in den Leuchten durch Einstellen einer bestimmten Farbe, Abwesenheit von Farbe und Blinken der ausgewählten Farbe, wobei alle in der programmierbaren elektronischen Schaltung (14) ausgebildet sind, gemäß dem empfangenen Signal und der empfangenen Eingabe ausführt.
7. Lichtsignalisierungssystem für Schalter gemäß Anspruch 2, das **dadurch gekennzeichnet ist, dass** die Einrichtung (22) zum Erfassen der Position der Steuerung (12) Sensoren sind, die elektrische Signale aussenden, wenn sich die Steuerung (12) über denselben befindet.
8. Lichtsignalisierungssystem für Schalter gemäß Anspruch 1, das **dadurch gekennzeichnet ist, dass** das Lichtsignalisierungssystem (10) eine Einrichtung zum Erzeugen von Tönen aufweist, die mit der elektronischen Schaltung (14) des Beleuchtungsmodusveränderungssystems (13) verbunden ist.
9. Lichtsignalisierungssystem für Schalter gemäß Anspruch 1, das **dadurch gekennzeichnet ist, dass** das Lichtsignalisierungssystem (10) ein Verriegelungssystem (16) der Position der Steuerung (12) aufweist.
10. Lichtsignalisierungssystem für Schalter gemäß Anspruch 1, das **dadurch gekennzeichnet ist, dass** das Lichtsignalisierungssystem (10) zwei oder mehr Serien von LEDs zur Bereitstellung der Beleuchtung, die parallel platziert sind, aufweist.
11. Lichtsignalisierungssystem für Schalter gemäß Anspruch 7, das **dadurch gekennzeichnet ist, dass** die Sensoren, die elektrische Signale aussenden, wenn sich die Steuerung (12) über denselben befindet, magnetische Sensoren sind.

#### Revendications

1. **SYSTÈME DE SIGNALISATION LUMINEUX POUR INTERRUPTEURS**, dans lequel le système de signalisation lumineux (10) comprend une commande (12) qui pilote les fonctions de l'interrupteur,

des moyens d'éclairage (18) pouvant éclairer la commande (12), au moins un système pour changer le mode d'éclairage (13) qui opère ce changement dans les moyens d'éclairage (18) selon des signaux ou impulsions reçu(e)s et un circuit électronique programmable (14), dans lequel ledit système de changement de mode d'éclairage (13) comporte au moins un signal d'entrée, reçu de composants externes ou internes au système de signalisation lumineux (10), dans lequel le signal d'entrée est connecté à un circuit électronique programmable (14) comprenant des modes d'éclairage associés à chaque signal, **caractérisé en ce que**

le système de signalisation lumineux (10) comprend un boîtier (20) contenant des moyens (15) de fixation à ou de détachement d'un interrupteur, et le système de signalisation lumineux (10) est conçu pour accueillir différents interrupteurs standards par l'incorporation d'une extension de l'arbre de commande du système de signalisation lumineux (10) conçue pour épouser le mouvement de l'arbre de l'interrupteur.

2. **SYSTÈME DE SIGNALISATION LUMINEUX POUR INTERRUPTEURS** selon la revendication 1, **caractérisé en ce que** le système de signalisation lumineux (10) comprend des moyens (22) pour détecter la position de la commande (12) et que le système de changement de mode d'éclairage (13) comporte au moins une connexion de signal interne configurée pour recevoir des signaux à partir de moyens (22) pour détecter la position de la commande (12).
3. **SYSTÈME DE SIGNALISATION LUMINEUX POUR INTERRUPTEURS** selon la revendication 1, **caractérisé en ce que** le système de changement de mode d'éclairage (13) comporte au moins une connexion à des composants externes à l'interrupteur (11) et au système de signalisation lumineux (10), et qui indiquent les paramètres de statut d'installation au moyen d'un signal externe qui parvient au circuit électronique (14) du système de changement de mode d'éclairage (13) par le biais de cette connexion.
4. **SYSTÈME DE SIGNALISATION LUMINEUX POUR INTERRUPTEURS** selon la revendication 3, **caractérisé en ce que** le système de changement de mode d'éclairage (13) comporte une barrette de raccordement externe pour connecter des composants externes (24) au système de signalisation lumineux (10), avec autant de connexions que de signaux devant être reçus.
5. **SYSTÈME DE SIGNALISATION LUMINEUX POUR INTERRUPTEURS** selon la revendication 1, **caractérisé en ce que** le système de changement de mode d'éclairage (13) comporte à son tour au

moins une connexion configurée pour recevoir des signaux internes à partir de moyens de détection de la position de la commande, ainsi qu'au moins une connexion à des composants externes à l'interrupteur (11) et au système de signalisation lumineux (10) et qui indiquent les paramètres de statut d'installation au moyen d'un signal externe qui parvient au circuit électronique (14) du système de changement de mode d'éclairage (13) par le biais de cette connexion.

6. **SYSTÈME DE SIGNALISATION LUMINEUX POUR INTERRUPTEURS** selon la revendication 1, **caractérisé en ce que** le système de changement de mode d'éclairage (13) exécute le mode d'éclairage dans les lumières en établissant une certaine couleur, une absence de couleur ou le clignotement de la couleur choisie, le tout étant configuré dans le circuit électronique programmable (14), selon le signal reçu et l'entrée reçue.
7. **SYSTÈME DE SIGNALISATION LUMINEUX POUR INTERRUPTEURS** selon la revendication 2, **caractérisé en ce que** les moyens (22) de détection de la position de la commande (12) sont des capteurs qui émettent des signaux électriques lorsque la commande (12) est située au-dessus d'eux.
8. **SYSTÈME DE SIGNALISATION LUMINEUX POUR INTERRUPTEURS** selon la revendication 1, **caractérisé en ce que** le système de signalisation lumineux (10) comporte des moyens pour créer des sons, connectés au circuit électronique (14) du système de changement de mode d'éclairage (13).
9. **SYSTÈME DE SIGNALISATION LUMINEUX POUR INTERRUPTEURS** selon la revendication 1, **caractérisé en ce que** le système de signalisation lumineux (10) comporte un système de verrouillage (16) de la position de commande (12).
10. **SYSTÈME DE SIGNALISATION LUMINEUX POUR INTERRUPTEURS** selon la revendication 1, **caractérisé en ce que** le système de signalisation lumineux (10) comporte deux ou plusieurs séries de LED pour fournir de l'éclairage, installées en parallèle.
11. **SYSTÈME DE SIGNALISATION LUMINEUX POUR INTERRUPTEURS** selon la revendication 7, **caractérisé en ce que** les capteurs émettant des signaux électriques lorsque la commande (12) est située au-dessus d'eux, sont des capteurs magnétiques.

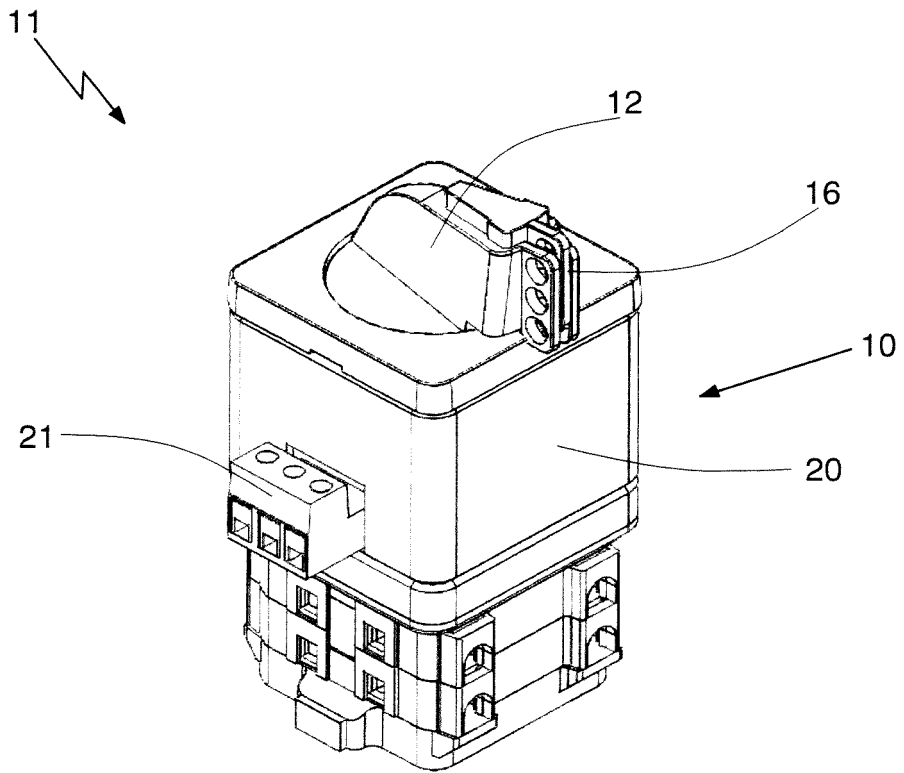

Fig. 1

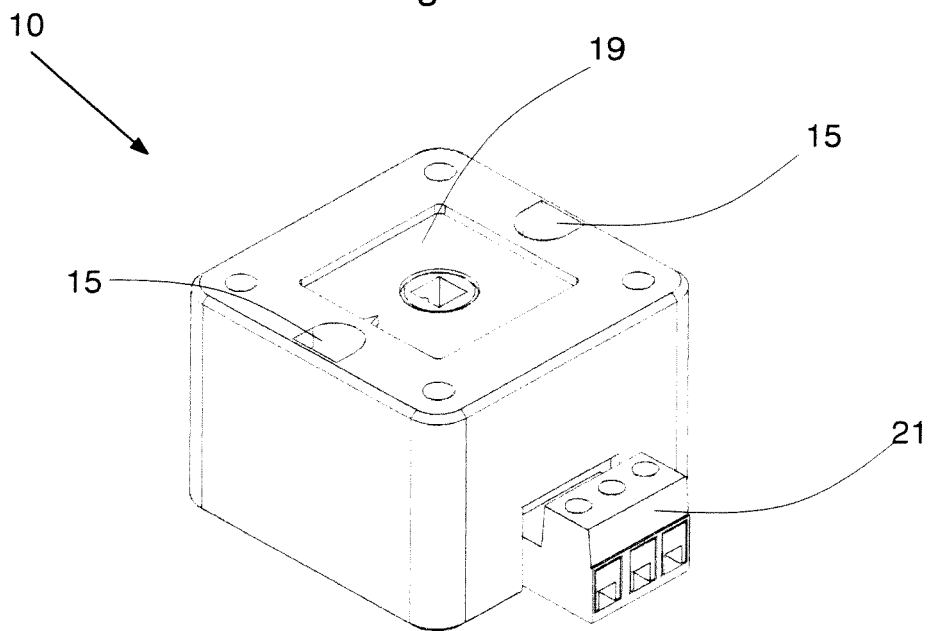

Fig. 2

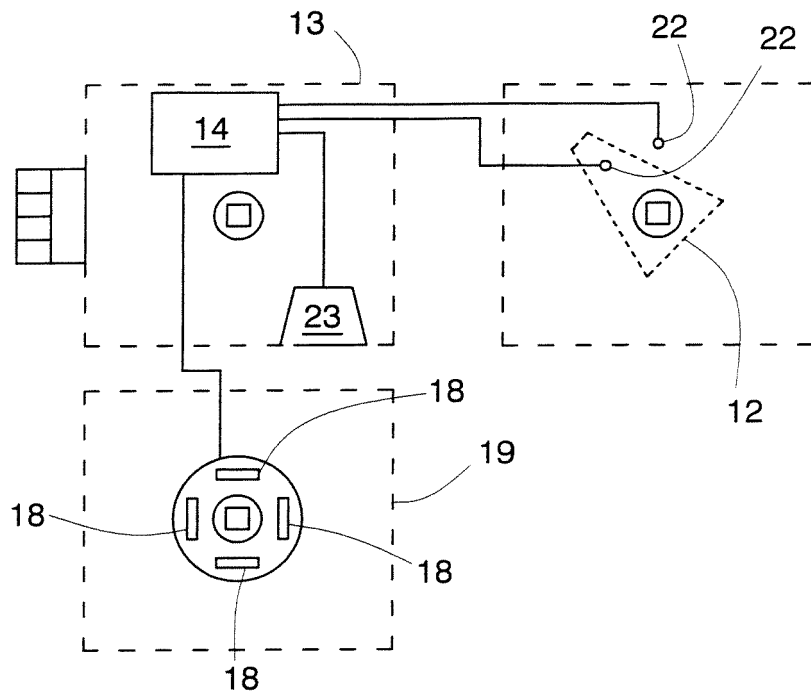

Fig. 3

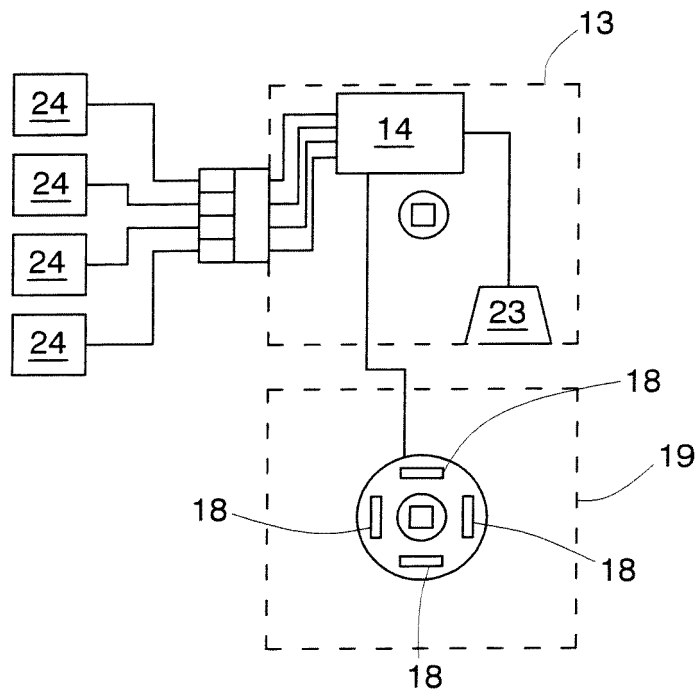

Fig. 4

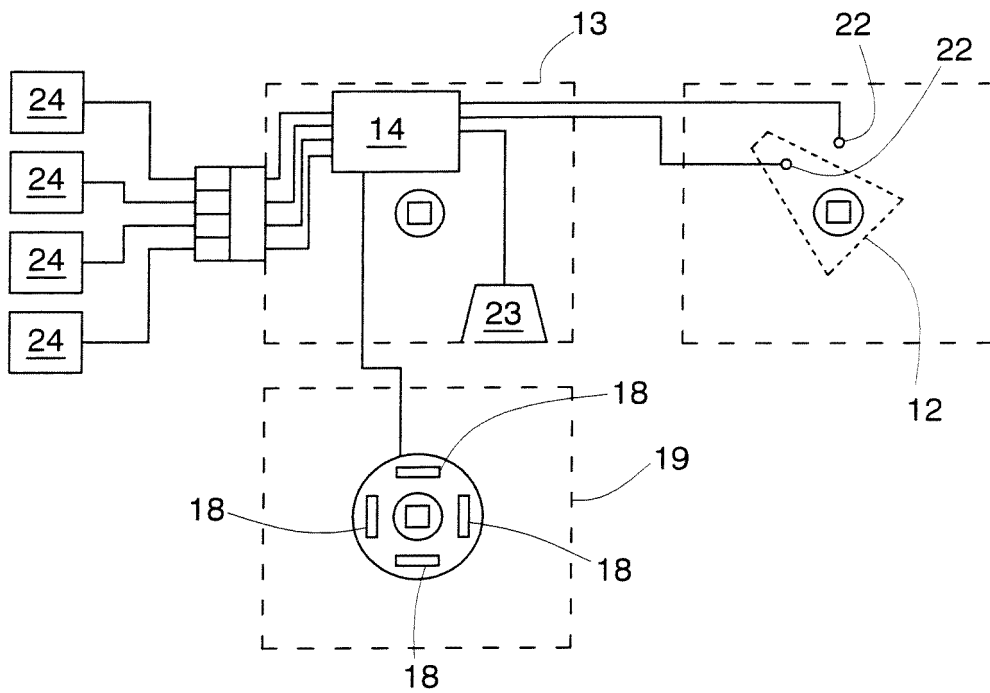

Fig. 5

**REFERENCES CITED IN THE DESCRIPTION**

*This list of references cited by the applicant is for the reader's convenience only. It does not form part of the European patent document. Even though great care has been taken in compiling the references, errors or omissions cannot be excluded and the EPO disclaims all liability in this regard.*

**Patent documents cited in the description**

- DE 102008035458 A1 [0006]
- US 2005155159 A1 [0007]
- US 5710544 A [0008]