

# United States Patent

Charrier

[15] 3,685,281

[45] Aug. 22, 1972

[54] **MEANS FOR SETTING THE HANDS OF A TIMEPIECE**

[72] Inventor: **Rolf Charrier**, Holderlinstrasse 7, D783 Emmendingen, Germany

[22] Filed: **Aug. 10, 1970**

[21] Appl. No.: **62,563**

[30] **Foreign Application Priority Data**

Aug. 12, 1969 France.....6927676

[52] U.S. Cl.....58/85.5

[51] Int. Cl.....G04b 27/00

[58] Field of Search.....58/57, 63, 73, 85.5

[56] **References Cited**

**UNITED STATES PATENTS**

1,841,750	1/1932	Matthiessen.....	58/85.5 X
1,982,495	11/1934	Browning.....	58/85.5 X
2,607,188	8/1952	Bourguin.....	58/85.5

**FOREIGN PATENTS OR APPLICATIONS**

1,165,855	10/1969	Great Britain.....	58/85.5
1,558,094	1/1969	France.....	58/85.5
1,175,614	9/1960	Germany.....	58/85.5
940,229	10/1963	Great Britain.....	58/85.5

*Primary Examiner*—Richard B. Wilkinson

*Assistant Examiner*—George H. Miller, Jr.

*Attorney*—Leon M. Strauss

[57] **ABSTRACT**

The invention relates to a device for the setting of the hand of a timepiece, which is equipped with sweep second means, in particular, for use in connection with car clocks and like timepieces, in which a knob for the hand-setting operation is centrally disposed of and passes with an operational part through the crystal of said clock, whereby said knob when depressed in the direction of said crystal causes coupling with a certain element carrying a hand, such as the second hand.

**5 Claims, 2 Drawing Figures**

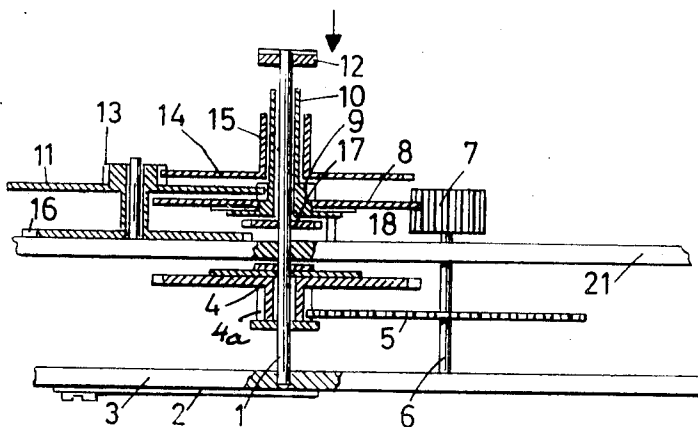

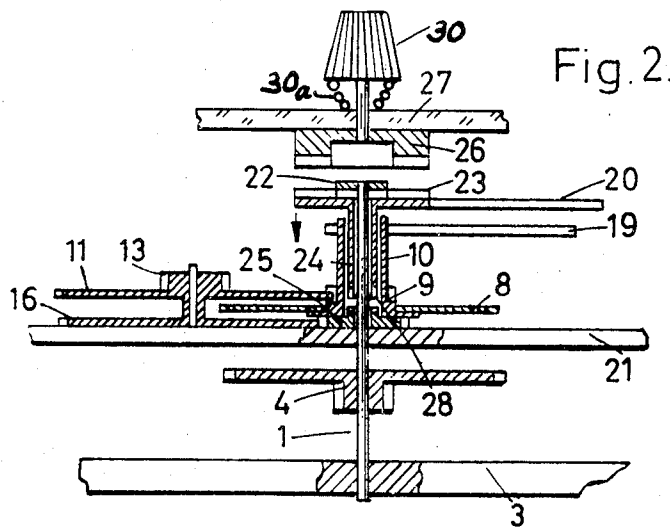
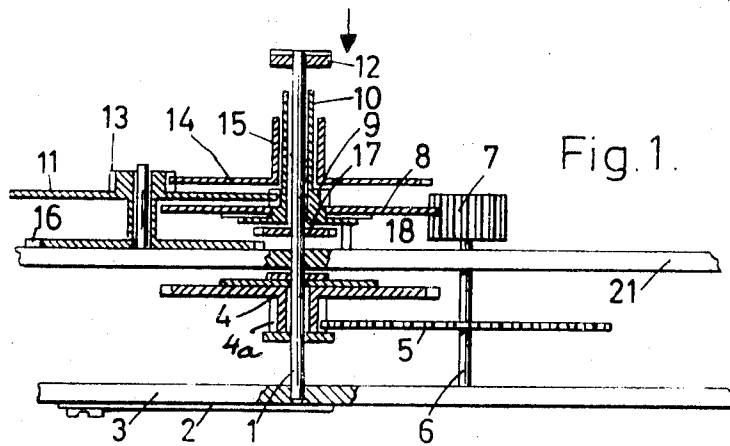

INVENTOR :

ROLF CHARRIER

BY *Konrad Strauß*  
ABT.

# MEANS FOR SETTING THE HANDS OF A TIMEPIECE

## SUMMARY OF THE INVENTION

In known hand-setting devices of the above-mentioned kind the hand-setting knob carries a claw, so that upon depressing the hand setting knob the claw spans the second hand, which is thus out-of-reach and then couples with the tubular support or cannon of the minute hand. Upon rotation of the hand-setting knob in such depressed position the minute hand and also the hour hand can be regulated and adjusted. It is however disadvantageous in known constructions that on depressing the hand-setting knob the second hand is liable to be easily damaged by the claw and the like.

It is an object of the present invention to avoid these and other known disadvantages, among which may be stressed, that excessive structural height of the hand adjustment mechanism including its hand-setting device were objectionable. The new hand-setting device according to the invention is characterized, in that during the depressing movement of the hand-setting knob a predetermined part carrying the second hand is automatically coupled with a wheel, which rigidly connects with the gear change, which in turn is in engagement with the pipe joints or cannons of the minute and hour hands.

It is another object of the present invention to provide means contributing to very durable and compact regulating means enabling convenient and easy adjustment of the second hand during timepiece action.

It is still a further object of the present invention to provide means conducive to a simplified operation for positively setting the second hand of a timepiece even by unskilled persons.

Accordingly, the invention consists in the features in the features of novel construction, combination of elements or parts, all as illustratively set forth in the ensuing description and drawings, the scope of the invention being indicated by the appended claims.

## BRIEF DESCRIPTION OF THE DRAWINGS

In the drawings:

FIG. 1 is a vertical sectional view through a first embodiment pursuant to the invention having an axially displaceable spindle of the second hand.

FIG. 2 is a somewhat modified sectional view through another embodiment according to the invention showing a device with a tubular or cannon connection carrying the second hand.

## DETAILED DESCRIPTION OF THE DISCLOSURE

Referring now more specifically to the drawings, there is disclosed an intermediate wheel spindle 6, which drives via an intermediate wheel 5 a pinion of the wheel 4 of the second hand. In the form of construction according to FIG. 1 this wheel 4 in mesh with pinion 4a is connected through a friction transmission or clutch with spindle 1, which carries the second hand.

Spindle 1 is mounted for rotation between the front plate 21 and rear plate 3 of the clock. The drive of the hand mechanism occurs through the intermediate wheel pinion 7 which engages with wheel 8 for the minute hand (FIG. 1). This minute wheel 8 is connected likewise through a friction drive or clutch with a

tubular support or cannon 10 carrying the minute hand, which may be fastened thereon and carries at the same time the minute pinion 9. The minute pinion 9, in turn, drives the change wheel 11, which via change pinion 13 drives the hour hand actuating wheel 14. The hour wheel 14 is rigidly connected with the hour tubular element or cannon 15, which carries the hour hand. Spindle 1 for the second hand carries at its forward end the second hand, whereas the minute support 10 carries the minute hand, and the hour tube connector 15 the hour hand.

With the change wheel or gear mechanism 11, 13 there is rigidly connected gear wheel 16 (FIGS. 1, 2). If in the embodiment of FIG. 1 spindle 1 is pushed inwardly via clutch part 12 by means of a hand-setting knob (not shown), the pinion 17 rigidly arranged on the seconds spindle 1 comes then into mesh or engagement position with gear wheel 16. Now if in this position the said spindle is turned by a knob to set the hands, the minute hand support 10 and the hour hand support 15 are adjusted at the same time via change wheel 11 and pinion 13. The minute wheel 8 and wheel 4 for the seconds hand with its pinion do not participate in this adjustment movement, and for this reason there is provided between the said wheel 4 with its pinion 4a and the said spindle 1 a friction clutch or mechanism, which is present in like manner as between the minute wheel 8 and the minute hand support 10. Spindle 1 carries at its forward end a clutch member 12 with which the hand-setting knob engages. The normal position of spindle 1 is ensured by a leaf or friction spring 2, which is arranged on and fastened to the face of the rear plate 3, as shown. Hence there are involved in the adjustment movement the following setting parts 17, 16, 11, 9, 10, 13, 14 and 15.

So that the minute hand tubular support or cannon and the corresponding hour hand support will not be able to participate in carrying out the axial movement of the seconds spindle 1, there is provided on plate 21 a pin 18, which shoulders on the minute hand support 10.

In the embodiment of FIG. 2, the hour hand support 15 with hour wheel 14 and the intermediate wheel spindle 6 with wheel 5 and pinion 7 have been omitted for the sake of greater clarity. The hand-setting knob 30 shown in FIG. 2, which is arranged in the center of the crystal 27, carries a friction producing member 26. This hand-setting knob with member 26 is used in the same or similar manner also in the example of FIG. 1.

In the example according to FIG. 2, a pinion 25 is provided which is in permanent engagement with wheel 16 of the gear change set-up 11, 13. Spindle 1 carries at its front end a clutch covering or like lining 22, which is normally coupled with the front face serration 23 of a tubular support element or cannon 24 which carries the second hand 20. If the hand-setting knob 30 is now pushed inwardly against coil spring action 30a, the clutch member 26 couples with first serration 23 at one end of the support 24. If the hand-setting knob is pushed farther in, tubular support 24 is displaced axially inwardly according to the arrow, its second end serration 28 being then coupled or in mesh with corresponding serrated face plate 22a of the pinion 25. If the hand-setting knob is now rotated or turned to set the hands, there occurs an adjustment of the gear change 11, 13 and hence an adjustment of the minute and hour sup-

ports 10, 15. Since during this adjustment movement the clutch covering 22 is out of engagement with the front-end serration 23, this adjustment movement is not communicated to the seconds spindle 1, so that the friction clutch between the seconds wheel 4 with its pinion and the seconds spindle 1 present in FIG. 1 may be omitted. In the example of FIG. 2, the seconds wheel 4 with its pinion is arranged rigidly on the seconds spindle 1.

In order that normally spindle 1 will be coupled through the lining 22 with the front-end serration 23 of the tubular element or cannon 24 carrying the second hand 20, the special lining 22 is rendered permanently magnetic, so that the end serration 23 is attracted by the magnetic lining 22 when the hand-setting knob is in the in operative position according to FIG. 2.

In FIG. 2 there is shown further the minute hand 19, which is arranged on the minute hand pipe support or cannon 10.

It is to be noted that during the aforesaid axial displacement hand-setting knob 30 operated by a person's pressure of his hand must overcome at first the action of spring 30a and then, from the instant coupling is established between parts 26 and 23, also the magnetic retention or attraction force between parts 22 and 23.

According to this invention there has been provided an extremely efficacious, compact and sturdy hand setting mechanism equipped with a spring-supported operating knob characterized by operable means 1 or 24 carrying the seconds hand 20 and provided with coupling means 17 or 28, 28a establishing during knob depressing movement in spindle direction operative connection of said coupling means with a change gear mechanism 16, 11, 13, which is constructed to transmit via said knob rotative engagement with respective support means 10, 15 for the minute and hour hands in order to set the same. Said spindle 1 is axially displaceable, said coupling means being constituted by a pinion 17 or gear wheel which during knob movement comes to mesh with the aforesaid change gear mechanism. It is also possible that the seconds hand 20 includes a support or cannon 24 which is provided at one end with serrations 23 and with a clutch covering 22 carried by the spindle 1 which passes through said cannon. The opposite end of the cannon is provided with other end serrations 28; a pinion 25 being in permanent engagement with said gear mechanism and said other end serrations 28 come thus to mesh with a serrated top face plate part 28a of the pinion 25 upon further or terminal knob depression, whereupon the minute and hour hands can be set without actuating the

spindle.

It can thus be seen that there has been provided according to this invention a novel set-up for operating and regulating a timepiece, the invention being distinguished from what is old and being described of the best mode contemplated of carrying out this invention; the scope of patent protection to be granted is defined by the ensuing claims.

What is claimed is:

1. In a device for setting the minute and hour hands of a timepiece, in particular of a car clock, equipped with sweep seconds hand, and having a hand-setting knob the axis of which is aligned with a spindle passing through the crystal of the timepiece, which knob upon being depressed effectuates coupling with the seconds hand; characterized by operable means carrying the seconds hand and provided with coupling means establishing during knob depressing movement in spindle direction an operative connection of said coupling means with a change gear mechanism, which is constructed to transmit via said knob, rotative engagement with respective support means for said minute and hour hands in order to set same.

2. In a device according to claim 1, characterized in that said spindle is axially displaceable upon said knob depressing movement, said coupling means being constituted by a pinion which during knob depressing movement comes to mesh with said change gear mechanism.

3. In a device according to claim 2, said coupling means including a gear wheel operatively connected to said seconds hand, and friction means joining said spindle with said seconds hand.

4. In a device according to claim 1, characterized in that said seconds hand is mounted on a cannon, said spindle passing through said cannon, which is provided at one end with serrations and with a clutch covering which is disengageable via said spindle from said one end serrations during preliminary knob depressing movement, said cannon having further an opposite other end provided with end serrations, and a pinion arranged in permanent engagement with said change gear mechanism and provided with a serrated plate face engageable with said other end serrations of said cannon upon farther knob depressing movement.

5. In a device according to claim 4, characterized in that said covering consists of permanently magnetic material normally attracting said one end serrations of said cannon when said knob is in its inactive position, in which said serrated plate face is disengaged from said other end serrations.

\* \* \* \* \*

55

60

65