

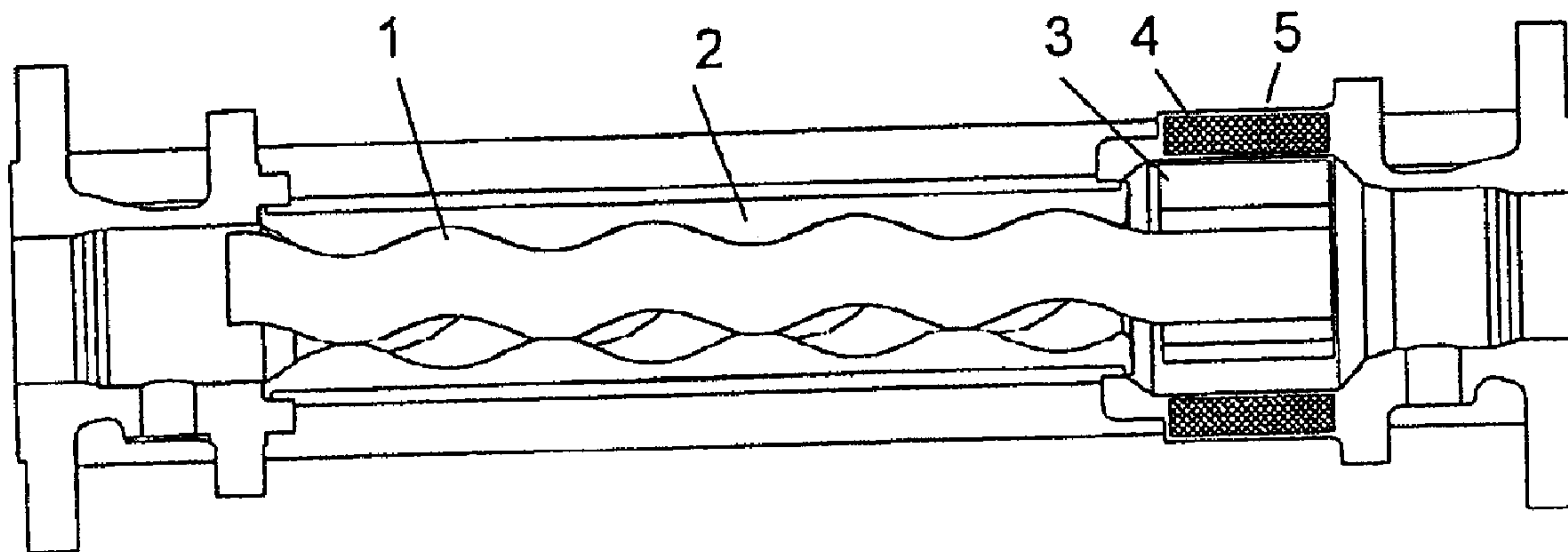

(86) Date de dépôt PCT/PCT Filing Date: 2005/07/15
 (87) Date publication PCT/PCT Publication Date: 2006/02/16
 (45) Date de délivrance/Issue Date: 2009/07/14
 (85) Entrée phase nationale/National Entry: 2006/07/17
 (86) N° demande PCT/PCT Application No.: DE 2005/001251
 (87) N° publication PCT/PCT Publication No.: 2006/015571
 (30) Priorité/Priority: 2004/08/10 (DE10 2004 038 686.2)

(51) Cl.Int./Int.Cl. *F04C 2/107* (2006.01)
 (72) Inventeurs/Inventors:
 JABERG, HELMUT, DE;
 SCHMIDT, DIRK, DE;
 SCHUELER, RALF, DE;
 RIBBE, THOMAS, DE;
 KREIDL, JOHANN, DE
 (73) Propriétaire/Owner:
 NETZSCH-MOHNOPUMPEN GMBH, DE
 (74) Agent: KIRBY EADES GALE BAKER

(54) Titre : POMPE A VIS SANS FIN EXCENTRIQUE POURVUE D'UN DISPOSITIF D'ENTRAINEMENT INTEGRE
 (54) Title: ECCENTRIC SCREW PUMP WITH INTEGRATED DRIVE



(57) **Abrégé/Abstract:**

The invention relates to an eccentric screw pump which comprises a stator (2) and a rotor (1) rotating therein as well as a drive motor for driving the rotor. The armature (3) of the drive motor is non-rotationally linked with the rotor and rotates inside a cylindrical pot (5) on an eccentric orbit. The torque for driving the rotor is generated by means of a stator winding (4).



ABSTRACT

The invention relates to an eccentric screw pump which comprises a stator (2) and a rotor (1) rotating therein as well as a drive motor for driving the rotor. The armature (3) of the drive motor is non-rotationally linked with the rotor and rotates inside a cylindrical pot (5) on an eccentric orbit. The torque for driving the rotor is generated by means of a stator winding (4)

ECCENTRIC SCREW PUMP WITH INTEGRATED DRIVEField of the Invention

The invention relates to a screw or eccentric screw pump such as is used especially for conveying highly viscous media or media mixed with solids.

Background

Eccentric screw pumps corresponding to the prior art generally have a fixed external stator and a rotor running therein. The rotor is generally driven by an external electric motor which is connected to the rotor by means of a Cardan shaft or flexible shaft. In the following descriptions no further distinction is made between screw and eccentric screw pumps since this has no effects on the principle forming the basis of the invention.

However, known eccentric screw pumps have a long overall shape and require maintenance because of the large number of moving parts in the motor, Cardan shaft and pump. In addition, in such an arrangement a seal with respect to the Cardan shaft is required on at least one side of the pump.

The arrangement from DE 102 51 846 A1 represents a substantial improvement here. Herein the rotor of an eccentric screw pump is at the same time part of the motor. Thus, the Cardan shaft in particular can be omitted. Such an arrangement has the disadvantage that only special rotors equipped with expensive magnetic materials can be used. Furthermore, as a result of the helical arrangement of the stator, a relatively complex stator winding is obtained, which also results in relatively high production costs.

- 2 -

Another approach to the solution is presented in DE 43 13 442 A1. As disclosed in Figure 24 for example, an eccentric screw pump is provided having an elastic stator and a rotor driven by a magnetic coupling. As a result of this arrangement, the magnetic coupling can be mounted using a simple bearing since the movement of the screw is compensated by the elastic stator. These pumps are not suitable for high pressures as a result of the high elasticity of the stators without jackets.

EP 0 357 317 B1 discloses a motor which simultaneously implement a rotary movement and a lifting movement in conjunction with an eccentric screw pump. Here also an elastic stator a without jacket is used to compensate for the eccentric movement of the screw. Thus, this pump is not suitable for high pressures.

Summary of the Invention

It is the object of the invention to configure an eccentric screw pump in such a manner that the torque required to drive the pump can be supplied without additional means which extend the overall shape of the pump and without shaft seals and shaft bearings and at the same time, the pump is also suitable for high pressures.

Certain exemplary embodiments can provide an eccentric screw pump, comprising: a. a stator and a rotor running therein; and b. a drive motor connected to the rotor for driving the rotor; the drive motor includes a first stator winding and a first armature; the first armature being constructed as an approximately cylindrical armature rotatable on an eccentric orbit inside an approximately cylindrical pot on which the first stator winding is arranged; the first armature and the rotor are rigidly connected.

- 3 -

Other embodiments provide an eccentric screw pump, comprising a stator and a rotor running therein. A drive motor is provided for driving the rotor which is connected to the rotor. This drive motor comprises an armature as well as a stator winding. The armature is constructed as an approximately cylindrical armature and rotates on an eccentric orbit inside an approximately cylindrical pot as a result of its rigid connection to the rotor. This pot is at least partly enclosed by a stator winding. Alternatively, the stator winding can also be integrated in this pot. As a result of such an arrangement, the drive and pump are integrated in an extremely space-saving manner in a single unit. At the same time, the mechanical construction is substantially simplified. Thus, no vulnerable Cardan shafts are required since the rotor runs completely closed in the system comprising stator and connected lines. No connection or contact is required from the rotor to points outside the system. Thus, the pump consisting of the rotor and the stator can be flange-mounted into an existing pipe without additional connections and shaft seals.

As a result of the arrangement according to various embodiments, the conversion member such as a Cardan shaft or a flexible shaft, for example, for transformation of the centric rotation of the drive motor into the eccentric movement of the rotor can also be omitted.

In a particularly advantageous embodiment, a second armature is provided as an approximately cylindrical armature. This armature is disposed on the end of the rotor opposite to the first armature. This armature is rigidly connected to the rotor and thus also rotates on an eccentric orbit inside a second pot. This second pot is likewise enclosed by a second stator winding or contains a second stator winding.

A further advantageous embodiment consists in that the motor comprising the armature and the stator winding is embodied

- 4 -

in the form of a reluctance motor. For this purpose, the stator winding has coils for producing a rotating magnetic field. Located in the armature is a preferably tooth-shaped part made of magnetically conductive or soft magnetic material, such as iron for example. In this case, the teeth are aligned according to the magnetic field. A rotation of the rotor can thus be achieved by a rotation of the magnetic field.

A control unit is provided for controlling the corresponding parts of the stator winding. This now controls the current flow through the stator winding in such a manner that in order to produce a torque, the flux is preferably guided through those areas of the pot which are at a minimal distance from the surface of the armature.

A position sensor which indicates the exact position of the rotor or the armature in relation to the stator is preferably provided for correct control of the coils. Such a position sensor can, for example, be implemented using magnets integrated in the rotor.

In a further advantageous embodiment, the motor is designed in the form of an asynchronous motor. For this purpose, the armature is embodied as a resistance armature or preferably as a short-circuiting armature. Furthermore, windings for producing a rotating field are provided in the stator winding. The rotating field induces voltages in the rotor windings or in the conducting rotor structure which results in corresponding currents depending on the electrical resistance of the windings or the conducting rotor structure. These currents in turn produce a magnetic field and therefore a torque. An optional control circuit, advantageously a frequency inverter, is provided for controlling the windings to produce the phase-shifted signals of variable frequency to generate a rotating field of the desired frequency of rotation.

- 5 -

Grooves for receiving rotor windings can optionally be provided in the rotor.

A different embodiment of the invention provides that axial holes through which the medium can flow are preferably provided in the armature. Thus, a diversion channel for the medium is no longer necessary. A particularly compact, space-saving structure of the arrangement is thus obtained.

In another advantageous embodiment of the invention, the magnetic components or permanent magnets in the armature as well as the coils in the stator are arranged so that a predetermined force is exerted in the axial direction on the rotor. It is especially advantageous if the axial force counteracts the pump pressure with the same strength. Preferably used to monitor the rotor position is a position controller which controls the position of the rotor using at least one position sensor.

A further embodiment of the invention provides a rotor which can be displaced in the axial direction by the axial force. A reduction in the break-away torque when starting up the pump can be achieved by means of this displaceability. Likewise, the pump outlet can thereby be closed by the rotor itself, for example. Alternatively, a valve body can naturally also be actuated by the axial movement of the rotor. Especially in the case of metering pumps, this allows particularly fine metering, free from overrun.

In a further advantageous embodiment of the invention coils in the armature have opposite polarity to the coils which transmit the torque to the rotor. As a result of this controllable reverse polarity, a force is produced in the rotor which acts in the direction opposite to the direction of flow of the pumped medium and thereby compensates or reduced the hydraulic forces produced by the medium on the

- 6 -

front sides of the rotor. The required numbers of coils of inverse polarity can be variably adapted to the conveying pressure produced.

Description of the Figures

The invention is described hereinafter using exemplary embodiments with reference to the drawings without restricting the general inventive idea.

Fig. 1 is a schematic view showing a device according to the invention in general form.

Fig. 2 is a perspective view showing a device according to the invention in general form.

Fig. 3 shows a device according to the invention with a second armature.

Fig. 4 is a perspective view of a device according to the invention with a second armature.

Detailed Description

Fig. 1 is a schematic diagram showing a device according to the invention in a section perpendicular to the axis of rotation. An eccentric screw pump has a rotor 1 which moves in a stator 2. The rotor 1 is rigidly connected to an armature 3. The armature rotates on an eccentric orbit inside the pot 5. In this case, the medium to be conveyed passes through the pot 5. At least one stator winding 4 is provided to produce the torque. In the exemplary embodiment the stator winding is integrated in the pot but can preferably be arranged outside the pot and thus outside the medium. However, it can optionally be integrated in the pot, for example, potted. The stator winding comprises individual

- 7 -

coils. These coils can optionally be supplied with current by a control unit.

A position sensor which indicates the exact position of the rotor or the armature in relation to the stator or the pot, is preferably provided for correct control of the coils. Such a position sensor can be implemented, for example by means of or with the aid of the magnets integrated in the rotor.

Figure 2 shows the arrangement shown previously in perspective view.

Figure 3 shows another device according to the invention with a second armature 3a. This second armature is arranged on the end of the rotor opposite to the first armature. Accordingly, a second pot 5a and a second stator winding 4a are allocated to the second armature to produce the torque. In such an arrangement it is advantageous if the two armatures are constructed such that they produce an axial thrust force directed towards one another which holds the two armatures and the rotor in a predetermined position. For this purpose the armatures can advantageously be constructed as at least slightly tapered.

Fig. 4 shows the arrangement shown previously in perspective view.

Reference list

- 1 Rotor
- 2 Stator
- 3 Armature
- 4 Winding
- 5 Pot

Claims:

1. An eccentric screw pump, comprising:
 - a. a stator and a rotor running therein; and
 - b. a drive motor connected to the rotor for driving the rotor; the drive motor includes a first stator winding and a first armature; the first armature being constructed as an approximately cylindrical armature rotatable on an eccentric orbit inside an approximately cylindrical pot on which the first stator winding is arranged; the first armature and the rotor are rigidly connected.
2. The eccentric screw pump according to claim 1, further comprising a second armature arranged as an approximately cylindrical armature on an end of the rotor opposite to the first armature and rotatable on an eccentric orbit inside the approximately cylindrical pot on which a second stator winding is arranged.
3. The eccentric screw pump according to claim 1 or 2, further comprising a plurality of rotors each having a following armature arranged as a chain of armatures and rotors.
4. The eccentric screw pump according to any one of claims 1 to 3, further comprising magnets selected from the group consisting of permanent magnets, reluctance magnets, and soft magnets provided in the first armature, the second armature, or the chain of armatures.
5. The eccentric screw pump according to claim 1, further comprising a control unit for controlling the first stator

- 9 -

winding based on a position of the first armature thereby exerting a torque on the rotor, wherein magnetic flux is guided through regions of the pot having a minimal distance from a surface of the first armature.

6. The eccentric screw pump according to claim 2, further comprising a control unit for controlling the first and second stator windings based on a position of the first and second armatures, respectively, thereby exerting a torque on the rotor, wherein magnetic flux is guided through regions of the pot having a minimal distance from a surface of the first and second armatures.

7. The eccentric screw pump according to any one of claims 1 to 6, wherein the first armature, the second armature and the chain of armatures include holes through which a medium can flow.

8. The eccentric screw pump according to claim 1, further comprising permanent magnets and coils arranged in the first armature for exerting an axial force on the rotor.

9. The eccentric screw pump according to claim 8, wherein the permanent magnets and the coils of the first armature are arranged in a plurality of groups wherein the axial force of each one of the plurality of groups act on the rotor in opposite directions.

10. The eccentric screw pump according to claim 8 or 9, wherein the rotor is displaceable based on the exerted axial force.

- 10 -

11. The eccentric screw pump according to claim 8 or 9, wherein additional axial force is exerted or an axial movement is generated to reduce break-away torque during pump startup.

12. The eccentric screw pump according to claim 8 or 9, wherein an axial movement is generated to close a pump outlet of the pump.

13. The eccentric screw pump according to claim 8 or 9, wherein an axial movement is generated to actuate a valve body of the pump.

Fig. 1

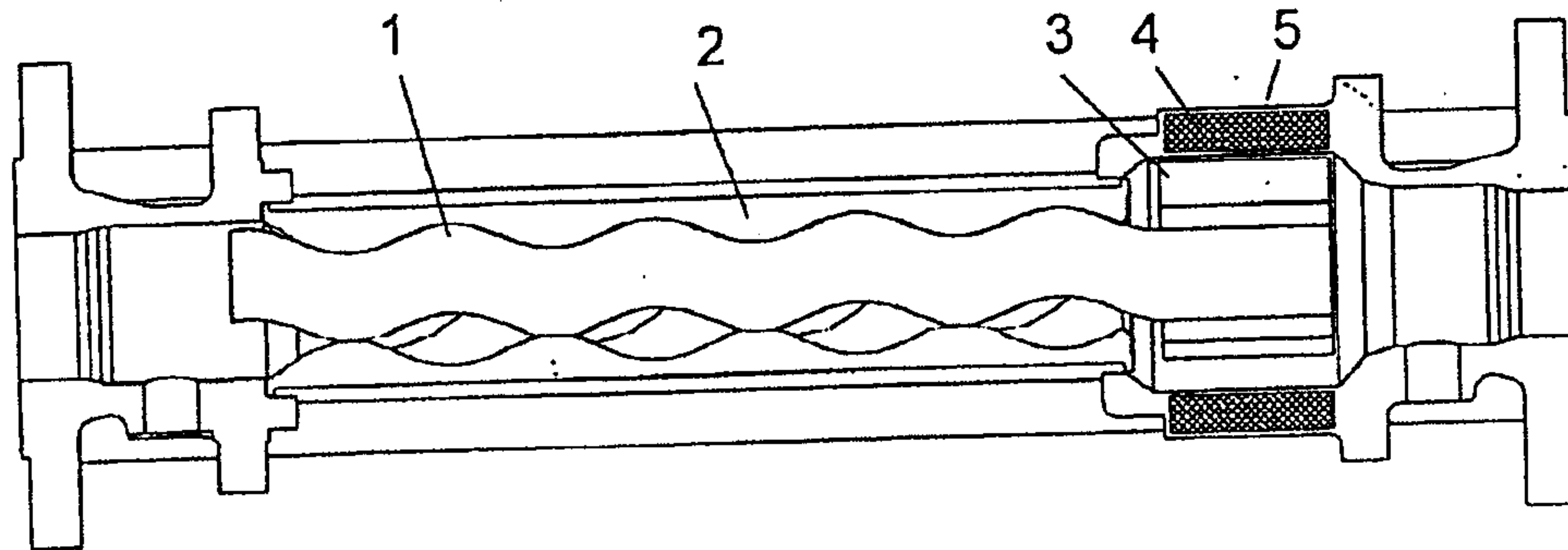

Fig. 2

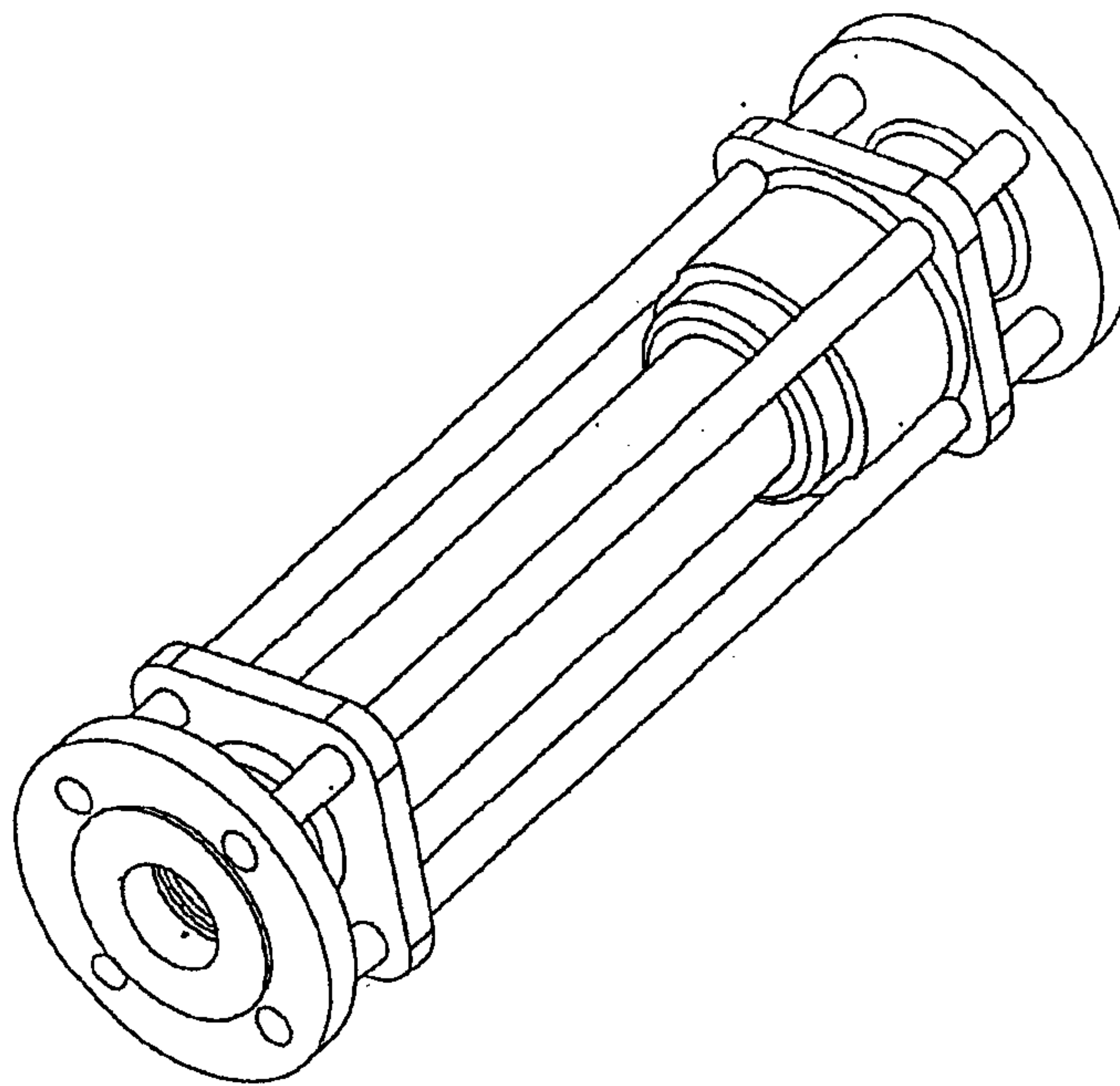

Fig. 3

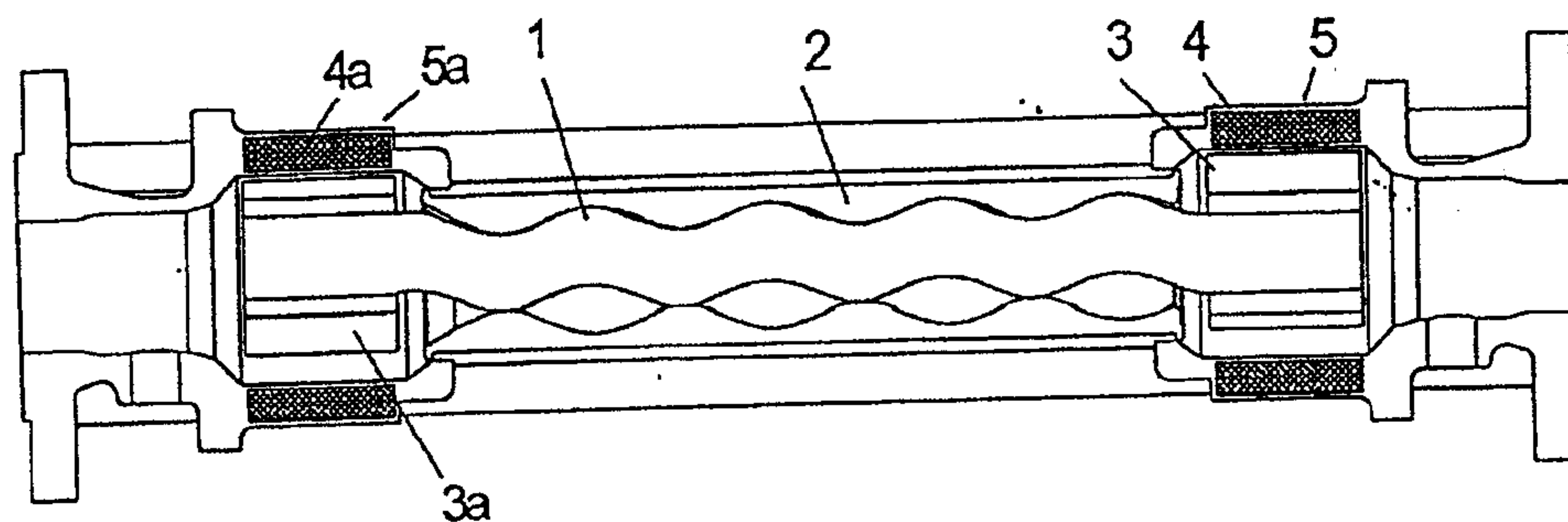

Fig. 4

