

(No Model.)

H. L. ROOSEVELT.
ELECTRIC LOCK.

No. 306,179.

Patented Oct. 7, 1884.

Fig. 1.

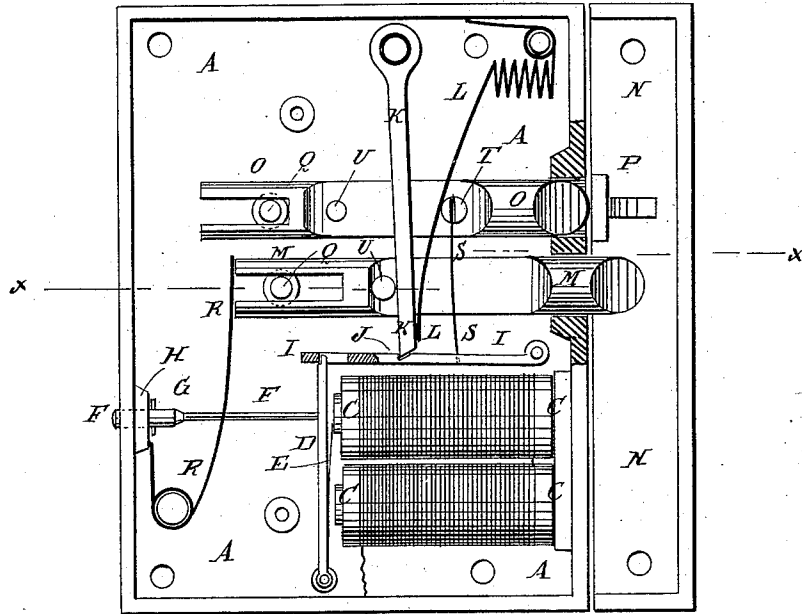
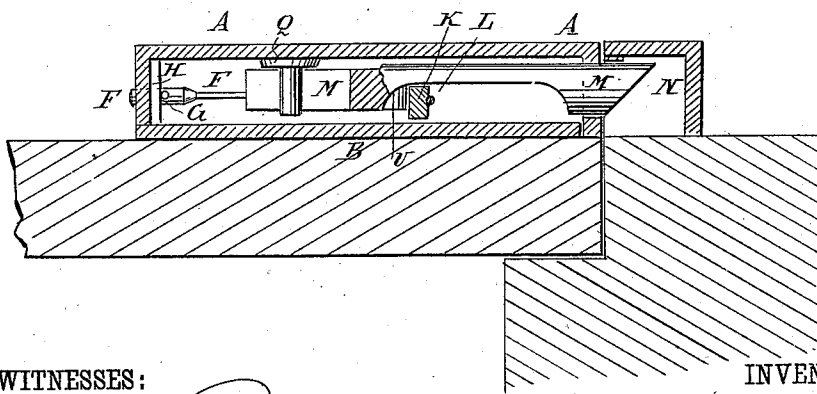

Fig. 2.



WITNESSES:

Chas. Viola
C. Sedgwick

INVENTOR:

H. L. Roosevelt
BY *Munn & Co*

ATTORNEYS.

UNITED STATES PATENT OFFICE.

HILBORNE L. ROOSEVELT, OF NEW YORK, N. Y.

ELECTRIC LOCK.

SPECIFICATION forming part of Letters Patent No. 306,179, dated October 7, 1884.

Application filed January 17, 1884. (No model.)

To all whom it may concern:

Be it known that I, HILBORNE L. ROOSEVELT, of the city, county, and State of New York, have invented certain new and useful Improvements in Electro-Magnetic Locks, of which the following is a full, clear, and exact description.

Reference is to be had to the accompanying drawings, forming part of this specification, in which similar letters of reference indicate corresponding parts in all the figures.

Figure 1 is an elevation of one of my improved locks, the face-plate being removed, and part being broken away to show the construction. Fig. 2 is a sectional plan view of the same, taken through the line *xx*, Fig. 1.

The object of this invention is to improve the construction of the electro-magnetic locks for which Letters Patent No. 178,382 were issued to me June 6, 1876, in such a manner as to make the said locks more sensitive to electric action, and thus more reliable in use.

The invention consists in the combination, with the armature of the magnet, the swinging plate, its spring, and the second bolt, of a trip-plate interposed between the said armature and swinging plate and a spring and stud connecting the said trip-plate and the second bolt, as will be hereinafter fully described.

A represents the case of the lock, to which the face-plate B is secured by screws in the ordinary manner.

C is a small electro-magnet, which is attached to the case A, and is connected with a battery in the ordinary manner.

D is the armature, which is hinged to the case A at one end, and is held back from the poles of the magnet C by a small spring, E, attached to the said armature and resting against one of the said poles. The armature D is held from being pushed back beyond magnetic influence by the rod F, which passes in through a hole in the edge of the case A, and is made of such a length that its inner end will be in contact with the said armature when the armature is out of contact with the magnet-poles. The outward movement of the rod F is limited by a cross-pin, G, which passes through it and rests against a washer, H,

through which the rod F passes, and which rests against the inner side of the edge of the lock-case A. The outer end of the rod F projects slightly, so that it can be pushed inward by the finger to release the armature from the trip-plate I by mechanical means without closing the electric circuit. The free end of the armature D enters an opening in the trip-plate I, and is rabbeted upon its outer side to receive the edge of the trip-plate I at the outer side of its said opening. The trip-plate I is hinged at its forward end to a stud attached to the case A, and in the upper side of its middle part is formed a recess, J, made with a square shoulder to receive the lower end of the swinging plate K, which is hinged at its upper end to a stud attached to the case A, and its lower end is held back by a spring, L, attached to the case A with its free end resting against the forward side of the lower end of the said plate K.

M is the lower or locking bolt, which passes through an opening in the forward edge of the case A, and enters a socket in the catch-plate N, attached to the door-jamb. Above the bolt M, and parallel therewith, is placed a second bolt, O, the forward end of which passes through an opening in the forward end of the case A and rests against a stop-plate, P, formed upon the catch-plate N, so that the bolt O can never be pushed forward when the door is closed. The rear ends of the bolts M O are slotted to receive studs Q, attached to the case A, to cause the said bolts to move forward and back in a straight line. The bolt M is pressed forward by a spring, R, attached to the case A, and the free end of which rests against the rear end of the said bolt M. The bolt O is pressed forward by a spring, S, the upper end of which is inserted in the slit of a stud, T, attached to the second bolt O, and its lower end is attached to the trip-plate I. The forward movements of the bolts M O is limited by the studs U, attached to the said bolts, and which come in contact with the rear side of the swinging-plate K. The rearward movement of the bolts M O is limited by the forward ends of the slots in their rear ends coming in contact with the studs Q. With this construction, when the door is open the bolts

M O are held forward, respectively, by the springs R S, the spring R having a greater strength than the spring L. As the door is closed the bolts M O are pushed back by the catch-plate N, and the bolt O is held back by the plate P, while the bolt M is thrown forward by the spring R into the socket of the said catch-plate N. The rearward movement of the bolt O puts the spring S under tension and raises the trip-plate I until it engages with the recessed upper end of the armature D and with the lower end of the swinging plate K. The rearward movement of the bolt O brings the stud T against the spring L and increases its tension, so that when the swinging plate K is released from the trip-plate I the said spring L will force the bolt M back against the pressure of the spring R and unlock the lock. With this arrangement, when the electric circuit is closed the attraction of the magnet A with-

draws the armature D from the trip-plate I and allows the said trip-plate to be forced down and the bolt M to be forced back by the pressure of the swinging plate K and spring L, unlocking the lock.

Having thus described my invention, what I claim as new, and desire to secure by Letters Patent, is—

In an electro-magnetic lock, the combination, with the armature D, the swinging plate K, the spring L, and the second bolt O, of the trip-plate I, the spring S, and the stud T, substantially as herein shown and described, whereby the lock is made more sensitive to the electric current, as set forth.

HILBORNE L. ROOSEVELT.

Witnesses:

JAMES T. GRAHAM,

C. SEDGWICK.