

(19) World Intellectual Property Organization
International Bureau



(43) International Publication Date
20 August 2009 (20.08.2009)

PCT

(10) International Publication Number
WO 2009/102851 A1

(51) International Patent Classification:
H01R 24/04 (2006.01)

(21) International Application Number:
PCT/US2009/033892

(22) International Filing Date:
12 February 2009 (12.02.2009)

(25) Filing Language: English

(26) Publication Language: English

(30) Priority Data:
61/028,040 12 February 2008 (12.02.2008) US
12/369,543 11 February 2009 (11.02.2009) US

(71) Applicant (for all designated States except US): **ADC GMBH** [DE/DE]; Beeskowdamm 3-11, 14167 Berlin (DE).

(72) Inventors; and

(75) Inventors/Applicants (for US only): **MURRAY, David, Patrick** [GB/GB]; 106 Longmead Avenue, Bishopston, Bristol BS7 8QF (GB). **HAMMOND, Bernard, Harold** [US/US]; 19095 East Chenango Circle, Aurora, CO 80015 (US).

(74) Agent: **BRUESS, Steven, C.**; Merchant & Gould P.C., P.O. Box 2903, Minneapolis, MN 55402-0903 (US).

(81) Designated States (unless otherwise indicated, for every kind of national protection available): AE, AG, AL, AM, AO, AT, AU, AZ, BA, BB, BG, BH, BR, BW, BY, BZ, CA, CH, CN, CO, CR, CU, CZ, DE, DK, DM, DO, DZ, EC, EE, EG, ES, FI, GB, GD, GE, GH, GM, GT, HN, HR, HU, ID, IL, IN, IS, JP, KE, KG, KM, KN, KP, KR, KZ, LA, LC, LK, LR, LS, LT, LU, LY, MA, MD, ME, MG, MK, MN, MW, MX, MY, MZ, NA, NG, NI, NO, NZ, OM, PG, PH, PL, PT, RO, RS, RU, SC, SD, SE, SG, SK, SL, SM, ST, SV, SY, TJ, TM, TN, TR, TT, TZ, UA, UG, US, UZ, VC, VN, ZA, ZM, ZW.

(84) Designated States (unless otherwise indicated, for every kind of regional protection available): ARIPO (BW, GH, GM, KE, LS, MW, MZ, NA, SD, SL, SZ, TZ, UG, ZM, ZW), Eurasian (AM, AZ, BY, KG, KZ, MD, RU, TJ, TM), European (AT, BE, BG, CH, CY, CZ, DE, DK, EE, ES, FI, FR, GB, GR, HR, HU, IE, IS, IT, LT, LU, LV, MC, MK, MT, NL, NO, PL, PT, RO, SE, SI, SK, TR), OAPI (BF, BJ, CF, CG, CI, CM, GA, GN, GQ, GW, ML, MR, NE, SN, TD, TG).

Published:

- with international search report (Art. 21(3))
- before the expiration of the time limit for amending the claims and to be republished in the event of receipt of amendments (Rule 48.2(h))

(54) Title: IMPROVED FAR END CROSSTALK COMPENSATION

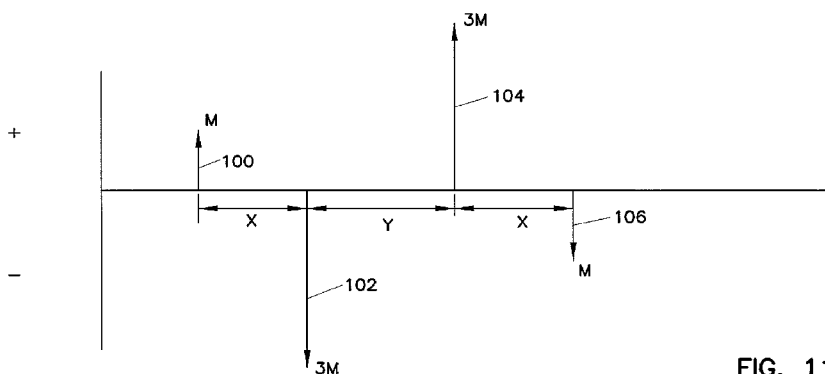

FIG. 11

(57) Abstract: Methods and systems for providing crosstalk compensation in a jack are disclosed. According to one method, the crosstalk compensation is adapted to compensate for undesired crosstalk generated at a capacitive coupling located at a plug inserted within the jack. The method includes positioning a first capacitive coupling a first time delay away from the capacitive coupling of the plug, the first capacitive coupling having a greater magnitude and an opposite polarity as compared to the capacitive coupling of the plug. The method also includes positioning a second capacitive coupling at a second time delay from the first capacitive coupling, the second time delay corresponding to an average time delay that optimizes near end crosstalk. The second capacitive coupling has generally the same overall magnitude but an opposite polarity as compared to the first capacitive coupling, and includes two capacitive elements spaced at different time delays from the first capacitive coupling.

WO 2009/102851 A1

IMPROVED FAR END CROSSTALK COMPENSATION**Cross Reference to Related Application**

This application is being filed on 12 February 2009, as a PCT International Patent application in the name of ADC GmbH, a German national corporation, applicant for the designation of all countries except the U.S., and David Patrick Murray, a citizen of Great Britain and Bernard Harold Hammond, a citizen of the U.S., applicants for the designation of the U.S. only, and claims priority to U.S. Provisional Patent Application Serial No. 61/028,040 filed on 12 February 2008 and U.S. Utility Patent Application Serial No. 12/369,543 filed on 11 February 2009.

Technical Field

The present invention relates generally to telecommunications equipment. More particularly, the present invention relates to telecommunications jacks that are configured to compensate for near end crosstalk and far end crosstalk.

Background

In the field of data communications, communications networks typically utilize techniques designed to maintain or improve the integrity of signals being transmitted via the network ("transmission signals"). To protect signal integrity, the communications networks should, at a minimum, satisfy compliance standards that are established by standards committees, such as the Institute of Electrical and Electronics Engineers (IEEE). The compliance standards help network designers provide communications networks that achieve at least minimum levels of signal integrity as well as some standard of compatibility.

One prevalent type of communication system uses twisted pairs of wires to transmit signals. In twisted pair systems, information such as video, audio and data are transmitted in the form of balanced signals over a pair of wires. The transmitted signal is defined by the voltage difference between the wires.

Crosstalk can negatively affect signal integrity in twisted pair systems. Crosstalk is unbalanced noise caused by capacitive and/or inductive coupling between wires and a twisted pair system. Crosstalk can exist in many variants, including near end crosstalk, far end crosstalk, and alien crosstalk. Near

end crosstalk refers to crosstalk detected at the same end of a wire pair as the inductance causing it, while far end crosstalk refers to crosstalk resulting from inductance at a far end of a wire pair. Alien crosstalk refers to crosstalk that occurs between different cables (i.e. different channels) in a bundle, rather than between individual wires or circuits within a single cable. Alien crosstalk can be introduced, for example, at a multiple connector interface. With increasing data transmission speeds, increasing alien crosstalk is generated among cables, and must be accounted for in designing systems in which compensation for the crosstalk is applied. The effects of all crosstalk become more difficult to address with increased signal frequency ranges.

The effects of crosstalk also increase when transmission signals are positioned closer to one another. Consequently, communications networks include areas that are especially susceptible to crosstalk because of the proximity of the transmission signals. In particular, communications networks include connectors that bring transmission signals in close proximity to one another. For example, the contacts of traditional connectors (e.g., jacks and plugs) used to provide interconnections in twisted pair telecommunications systems are particularly susceptible to crosstalk interference. Furthermore, alien crosstalk has been observed that could not be explained by the current models which sum connectors and cable component results to calculate channel results. This "excess" alien crosstalk is not compensated for in existing designs.

Figure 1 shows a prior art panel 20 adapted for use with a twisted pair telecommunications system. The panel 20 includes a plurality of jacks 22 placed in close proximity with one another. Each jack 22 includes a port 24 adapted to receive a standard telecommunications plug 26. Each of the jacks 22 is adapted to be terminated to four twisted pairs of transmission wires. As shown at Figure 2, each of the jacks 22 includes eight contact springs labeled as having positions 1-8. In use, contact springs 4 and 5 are connected to a first pair of wires, the contact springs 1 and 2 are connected to a second pair of wires, contact springs 3 and 6 are connected to a third pair of wires, and contact springs 7 and 8 are connected to a fourth pair of wires. As shown at Figure 3, a typical plug 26 also has eight contacts (labeled 1-8) adapted to interconnect with the corresponding eight contacts of the jack 22 when the plug is inserted within the port 24.

To promote circuit density, the contacts of the jacks and the plugs are required to be positioned in fairly close proximity to one another. Thus, the contact regions of the jacks and plugs are particularly susceptible to crosstalk. Furthermore, certain pairs of contacts are more susceptible to crosstalk than others. For example, the first and third pairs of contacts in the plugs and jacks are typically most susceptible to crosstalk.

To address the problems of crosstalk, jacks have been designed with contact spring configurations adapted to reduce the capacitive coupling generated between the contact springs so that crosstalk is minimized. An alternative approach involves intentionally generating crosstalk having a magnitude and phase designed to compensate for or correct crosstalk caused at the plug or jack. Typically, crosstalk compensation can be provided by manipulating the positioning of the contacts or leads of the jack or can be provided on a circuit board used to electrically connect the contact springs of the jack to insulation displacement connectors of the jack.

The telecommunications industry is constantly striving toward larger signal frequency ranges. As transmission frequency ranges widen, crosstalk becomes more problematic. Thus, there is a need for further development relating to crosstalk remediation.

20

Summary

In accordance with the present disclosure, the above and other problems are solved by the following.

In a first aspect, a method for providing crosstalk compensation in a jack is disclosed. According to the method, the crosstalk compensation is adapted to compensate for undesired crosstalk generated at a capacitive coupling located at a plug inserted within the jack. The method includes positioning a first capacitive coupling a first time delay away from the capacitive coupling of the plug, the first capacitive coupling having a greater magnitude and an opposite polarity as compared to the capacitive coupling of the plug. The method also includes positioning a second capacitive coupling at a second time delay from the first capacitive coupling, the second time delay corresponding to an average time delay that optimizes near end crosstalk. The second capacitive coupling has generally the

same overall magnitude but an opposite polarity as compared to the first capacitive coupling, and includes two capacitive elements spaced at different time delays from the first capacitive coupling.

In a second aspect, a telecommunications jack is disclosed for use in
5 a twisted pair system. The jack includes a housing defining a port for receiving a plug. The jack also includes a plurality of contact springs adapted to make electrical contact with the plug when the plug is inserted into the port of the housing. The jack includes a plurality of wire termination contacts for terminating wires to the jack,
and a circuit board including conductive tracks that electrically connect the
10 contact springs to the wire termination contacts. The jack further includes a crosstalk compensation arrangement that provides crosstalk compensation between selected tracks of the circuit board. The crosstalk compensation arrangement includes a first zone of compensation a first time delay away from the capacitive coupling of the plug and a second zone of compensation at an second time delay
15 from the first zone of compensation, the second zone of compensation including two capacitive elements spaced at different time delays from the first zone of compensation to optimize far end crosstalk and having an average time delay that optimizes near end crosstalk.

In a third aspect, a crosstalk compensation system within a
20 telecommunications jack is disclosed. The crosstalk compensation system includes a circuit board and a plurality of contact springs mounted on the circuit board, the contact springs including first, second, third, fourth, fifth, sixth, seventh and eighth consecutively arranged contact springs. The crosstalk compensation system further includes a plurality of wire termination contacts mounted on the circuit board, the
25 wire termination contents including first, second, third, fourth, fifth, sixth, seventh and eighth wire termination contacts for terminating wires to the jack, and a plurality of tracks on the circuit board, the tracks including first, second, third, fourth, fifth, sixth, seventh and eighth tracks that respectively electrically connect the first, second, third, fourth, fifth, sixth, seventh and eighth contact springs to the first,
30 second, third, fourth, fifth, sixth, seventh and eighth wire termination contacts. The crosstalk compensation system includes a crosstalk compensation arrangement that provides crosstalk compensation between the tracks of the circuit board. The crosstalk compensation arrangement includes a first zone of compensation a first

time delay away from the contact springs and a second zone of compensation at an second time delay from the first zone of compensation, the second zone of compensation including two capacitive elements spaced at different time delays from the first capacitive coupling and having an average time delay that that
5 optimizes near end crosstalk.

In a fourth aspect, a method for determining the positions of first and second zones of crosstalk compensation in a jack is disclosed. The method is directed to a jack in which the first and second zones of crosstalk compensation are adapted to compensate for undesired crosstalk caused by an undesired capacitive
10 coupling located at a plug inserted within the jack, the first zone of crosstalk compensation including a first capacitive coupling positioned a first time delay away from the undesired capacitive coupling of the plug, the first capacitive coupling having a greater magnitude and an opposite polarity as compared to the undesired capacitive coupling of the plug, the second zone of crosstalk compensation including
15 a second capacitive coupling having two capacitive elements positioned, on average, a second time delay away from the first capacitive coupling, the second capacitive coupling having generally the same magnitude but an opposite polarity as compared to the first capacitive coupling. The method includes positioning the first and second capacitive couplings in initial positions in which the first and second time
20 delays are generally equal to one another. The method also includes adjusting the position of the second capacitive coupling from the initial position to an adjusted position to provide improved near end crosstalk compensation. The method further includes adjusting the position of the first and second capacitive elements to different lengths to provide improved far end crosstalk compensation while
25 maintaining the adjusted position of the second capacitive coupling as the average position of the first and second capacitive elements.

In a fifth aspect, a method of designing a crosstalk compensation system for a telecommunications jack is disclosed. The method includes positioning a first zone of crosstalk compensation across at least a first wire pair and a second
30 wire pair on a circuit board within a telecommunications jack, the first zone of crosstalk compensation placed at a first distance from contact springs associated with the first wire pair and the second wire pair. The method also includes positioning a second zone of crosstalk compensation across the at least first and

second wire pairs at a second distance from the first zone of crosstalk compensation, the second zone of crosstalk compensation including a first capacitive coupling and a second capacitive coupling. The method further includes altering the position of the capacitive couplings to establish a distance between the first capacitive coupling
5 and the second capacitive coupling while maintaining the second distance as an average distance from the first zone of crosstalk compensation. Using the method disclosed, altering the position of the capacitive couplings provides improved far end crosstalk compensation.

Brief Description of the Drawings

10 Figure 1 is a perspective view of a prior art telecommunications panel;

Figure 2 is a schematic illustration of a prior art jack;

Figure 3 is a schematic representation of a prior art telecommunications plug;

15 Figure 4 is a front, perspective view of a telecommunications jack having features that are examples of inventive aspects in accordance with the principles of the present disclosure;

Figure 5 is an exploded view of the jack of Figure 4;

20 Figure 6 is a side view of the circuit board, insulation displacement connectors and contact springs of the telecommunications jack of Figure 4;

Figure 7 is a front view of the circuit board, contact springs and insulation displacement connectors of Figure 6;

Figure 8 is a top view of the circuit board and contact springs of Figure 6;

25 Figure 9 is a cross-sectional view taken along section line 9-9 of Figure 8;

Figure 10 is a schematic diagram showing a crosstalk compensation scheme incorporated into the telecommunications jack of Figure 4;

30 Figure 11 is a schematic diagram showing a compensation arrangement used to provide crosstalk compensation between the 4-5 and 3-6 pairs of the telecommunications jack of Figure 4;

Figure 12 is a schematic vector diagram showing a compensation arrangement used to provide crosstalk compensation between the 4-5 and 7-8 pairs of the telecommunications jack of Figure 4;

5 Figure 13 is a tracing overlay view of the circuit board used in the telecommunications jack of Figure 4;

Figure 14 shows a front conductive layer of the circuit board used in the telecommunications jack of Figure 4;

Figure 15 shows a middle conductive layer of the circuit board used in the telecommunications jack of Figure 4; and

10 Figure 16 is shows a back conductive layer of the circuit board used in the telecommunications jack of Figure 4.

Detailed Description

Various embodiments of the present disclosure will be described in detail with reference to the drawings, wherein like reference numerals represent like parts and assemblies throughout the several views. Additionally, any examples set
15 forth in this specification are not intended to be limiting and merely set forth some of the many possible embodiments for how aspects of the disclosure may be practiced.

In general, the present disclosure relates to methods and systems for
20 improving far end crosstalk compensation without adversely affecting near end crosstalk compensation within a telecommunications jack. The present disclosure generally describes crosstalk compensation schemes in which near end and far end crosstalk are accounted for and compensated against. In certain aspects, the crosstalk compensation is achieved by use of at least two stages of capacitive
25 compensation, in which the second stage is placed at an average time delay from the first stage such that near end crosstalk is optimized. The second stage has at least two capacitive elements spaced at different time delays from the first capacitive coupling to optimize far end crosstalk.

The present disclosure also relates to methods and systems for
30 compensating for alien crosstalk in a telecommunications jack. The present disclosure describes crosstalk compensation schemes in which alien crosstalk is compensated against, such as by selecting imbalanced capacitive arrangements

across wire pairs to reduce the overall crosstalk experienced in a system, despite the potential for imbalanced compensation between wire pairs within a single jack.

Figures 4 and 5 show a telecommunications jack 120 (i.e., a telecommunications connector) having features that are examples of inventive
5 aspects in accordance with the principles of the present disclosure. The jack 120 includes a dielectric housing 122 having a front piece 124 and a rear piece 126. The front and rear pieces 124, 126 can be interconnected by a snap fit connection. The front piece 124 defines a front port 128 sized and shaped to receive a conventional telecommunications plug (e.g., an RJ style plug such as an RJ 45 plug). The rear
10 piece 126 defines an insulation displacement connector interface and includes a plurality of towers 130 adapted to house insulation displacement connector blades/contacts. The jack 120 further includes a circuit board 132 that mounts between the front and rear pieces 124, 126 of the housing 122. A plurality of contact springs CS_1 - CS_8 are terminated to a front side of the circuit board 132. A
15 plurality of insulation displacement connector blades IDC_1 - IDC_8 are terminated to a back side of the circuit board 132. The contact springs CS_1 - CS_8 extend into the front port 128 and are adapted to be electrically connected to corresponding contacts provided on a plug when the plug is inserted into the front port 128. The insulation displacement connector blades IDC_1 - IDC_8 fit within the towers 130 of the rear piece
20 126 of the housing 122. The circuit board 132 has tracks T_1 - T_8 (e.g., tracings, see Figures 14-17) that respectively electrically connect the contact springs CS_1 - CS_8 to the insulation displacement connector blades IDC_1 - IDC_8 .

In use, wires are electrically connected to the contact springs CS_1 - CS_8 by inserting the wires between pairs of the insulation displacement connector blades
25 IDC_1 - IDC_8 . When the wires are inserted between pairs of the insulation displacement connector blades IDC_1 - IDC_8 , the blades cut through the insulation of the wires and make electrical contact with the center conductors of the wires. In this way, the insulation displacement connector blades IDC_1 - IDC_8 , which are electrically connected to the contact springs CS_1 - CS_8 by the tracks on the circuit board, provide
30 an efficient means for electrically connecting a twisted pair of wires to the contact springs CS_1 - CS_8 of the jack 120.

The contact springs CS_1 - CS_8 are shown more clearly in Figures 6-8. The relative positioning, shape and curvature of the contact springs CS_1 - CS_8 is preferably adapted to provide some initial crosstalk compensation at the jack 120.

The circuit board 132 of the jack 120 is preferably a multiple layer
5 circuit board. For example, Figure 9 shows the circuit board 132 including a first
conductive layer 140, a second conductive layer 142 and a third conductive layer
144. The first and second conductive layers 140, 142 are separated by a first
dielectric layer 146. The second and third conductive layers 142, 144 are separated
10 by a second dielectric layer 148. The first conductive layer 140 is located at a front
side of the circuit board 132 and the third conductive layer 144 is located at a back
side of the circuit board 132. The contact springs CS_1 - CS_8 are mounted at the front
side of the circuit board 132, while the insulation displacement connector blades
 IDC_1 - IDC_8 are mounted at the back side of the circuit board 132. Vias extend
15 through the first and second dielectric layers 146, 148 to provide electrical
connections between the conductive layers 140, 142 and 144. The conductive layers
140, 142 and 144 are defined by electrically the conductive tracks T_1 - T_8 (see Figures
14-17). The tracks T_1 - T_8 are formed (e.g., etched or otherwise provided) on the
dielectric layers 146, 148.

The circuit board 132 preferably includes structures for compensating
20 for near end crosstalk that occurs at the jack/plug interface. In certain embodiments,
the structures for compensating for near end crosstalk include capacitive couplings
provided between the first and second conductive layers 140, 142. In preferred
embodiments, the capacitive couplings are provided by sets of opposing, generally
parallel capacitive plates located at the first and second conductive layers 140, 142.
25 To increase the magnitude of the capacitive coupling provided between the
capacitive plates of the first and second conductive layers 140, 142, it is desirable
for the first dielectric layer 146 to be relatively thin. For example, in certain
embodiments the first dielectric layer 146 can have a thickness t_1 less than about .01
inches, or less than about .0075 inches, or less than about .005 inches, or less than
30 .003 inches. In other embodiments, the thickness t_1 can be in the range of .001
inches to .003 inches or in the range of .001 inches to .005 inches. In a preferred
embodiment, the thickness t_1 is about .002 inches.

In certain embodiments, the first dielectric layer 146 can be made of a material having a relatively low dielectric constant. As used herein, dielectric constants are dielectric constants relative to air. In certain embodiments, the dielectric constant of the first dielectric layer 146 can be equal to or less than about 5. In other embodiments, the dielectric constant of the first dielectric layer 146 can be less than or equal to about 4 or less than or equal to about 3. An example material for manufacturing the first dielectric layer 146 is a flame resistant 4 (FR-4) circuit board material. FR-4 circuit board material is a composite of a resin epoxy reinforced with a woven fiberglass mat.

The second dielectric layer 148 is preferably configured to isolate the third conductive layer 144 from the first and second conductive layers 140, 142. The second dielectric layer 148 can have a different thickness t_2 than the thickness t_1 of the first dielectric layer 146. In certain embodiments, the second dielectric layer 148 is at least 2.5 times thicker than the first dielectric layer 146 or at least five times thicker than the first dielectric layer 146. In still other embodiments, the second dielectric layer 148 is at least 10 times or at least 20 times thicker than the first dielectric layer 146. In one example embodiment, the thickness t_2 of the second dielectric layer 148 is in the range of .050 inches to .055 inches. In another example embodiment, the thickness t_2 of the second dielectric layer 148 is in the range of .040 inches to .050 inches.

The second dielectric layer 148 can also be manufactured of a different material as compared to the first dielectric layer 146. In certain embodiments, the second dielectric layer can have different dielectric properties as compared to the first dielectric layer 146. For example, in certain embodiments the first dielectric layer 146 can have a dielectric constant that is greater (e.g., at least 1.5 times or at least 2 times greater) than the dielectric constant of the second dielectric layer 148. In one example, the second dielectric layer 148 can be manufactured of a material such as FR-4. Of course, it will be appreciated that other materials could also be used.

The circuit board 132 includes a number of capacitive couplings having magnitudes and locations adapted to compensate for near end crosstalk and far end crosstalk. These forms of crosstalk are particularly problematic between the 4-5 and 3-6 pairs. To compensate for near end crosstalk between the 4-5 and 3-6

pairs, three interdependent zones of compensation are used between tracks T_{4-5} and tracks T_{3-6} . As shown at Figure 10, the three interdependent zones of compensation include a first zone of compensation Z_{A1} , a second zone of compensation Z_{A2} and a third zone of compensation Z_{A3} . The first zone of compensation Z_{A1} includes a
5 capacitive coupling C1 between track T_3 and track T_5 , and a capacitive coupling C2 between track T_4 and track T_6 . The second zone of compensation Z_{A2} includes a capacitive coupling C3 between track T_3 and track T_4 , and a capacitive coupling C4 between track T_5 and track T_6 . The third zone of compensation Z_{A3} includes a
10 capacitive coupling C5 between track T_3 and track T_5 , and a capacitive coupling C6 between track T_4 and track T_6 .

To compensate for far end crosstalk, the capacitive couplings C3 and C4 are spaced apart, such that the average distance between the zones of compensation is as described below in Figure 11, but the distances for the C3 and C4 couplings differ. As shown, coupling C3 is placed closer to the first zone of
15 compensation Z_{A1} than coupling C4 while maintaining the average position of the zone Z_{A2} such that the distance between zones is as described below in Figure 11.

In the embodiments shown in the present disclosure, the capacitive couplings C1 and C2 are equal in magnitude and location, maintaining symmetry across the pairs. However, in certain embodiments, capacitive couplings C1 and C2
20 may be selected such that they differ in magnitude to compensate for alien crosstalk including the "excess" crosstalk previously mentioned, which is noted to be worst in the case of the 3-6 pair. Specifically, it was determined that changes to alien crosstalk can be made, both positively and negatively, by purposefully modifying the size of the compensating capacitors, causing them to become asymmetric in size
25 and coupling. For example, in certain embodiments, the magnitude of capacitor C1 is greater than the magnitude of capacitor C2, which can reduce the alien crosstalk generated at the 3-6 pair. It is observed that, analogously to varying the magnitudes of C1 and C2, varying the relative magnitudes of the capacitive couplings within a zone of compensation in the compensation between the 4-5 and 3-6 pairs can
30 improve the alien crosstalk observed. This is understood to have the effect of compensating for the overall plug and jack configuration, as opposed to typical crosstalk compensation schemes which generally only account for crosstalk

generated in the jack. Additional details regarding methods and configurations for compensating for alien crosstalk are described below.

To address overall crosstalk between the 4-5 and 3-6 pairs, a relatively large amount of capacitance is used. This large amount of capacitance can cause the jack to have unacceptable levels of return loss. Methods for addressing this return loss are addressed in U.S. Patent Application No. 11/402,544, filed April 11, 2006 and entitled "TELECOMMUNICATIONS JACK WITH CROSSTALK MULTI-ZONE CROSSTALK COMPENSATION AND METHOD FOR DESIGNING", which is hereby incorporated by reference in its entirety.

Figure 11 is a schematic diagram representative of the compensation arrangement used to provide crosstalk compensation between the 4-5 and 3-6 pairs. As shown at Figure 11, the compensation arrangement includes a first vector 100, a second vector 102, a third vector 104, and a fourth vector 106. The first vector 100 and the third vector 104 have positive polarities, while the second vector 102 and the fourth vector 106 have negative polarities. The first vector 100 has a magnitude of M and corresponds to crosstalk introduced at the plug. The second vector 102 has a magnitude of about $-3M$ and corresponds to the overall crosstalk introduced at the first zone of crosstalk Z_{A1} generated by the board and springs. The third vector 104 has a magnitude of about $3M$ and corresponds to the overall crosstalk introduced at the second zone of compensation Z_{A2} . The fourth vector 106 has a magnitude of about $-M$ and corresponds to the overall crosstalk introduced at the third zone of compensation Z_{A3} . It will be appreciated that each vector is a lump sum of the total crosstalk or crosstalk compensation provided at each respective compensation zone, with the vectors being placed at the centers or midpoints of the compensation zones.

In designing the compensation scheme of Figure 11, a number of factors are taken into consideration when determining the placement of the compensation zones. One factor includes the need to accommodate signal travel in both directions (i.e., in forward and reverse directions) through the tracks on the circuit board. To accommodate forward and reverse transmissions through the circuit board, the compensation scheme preferably has a configuration with forward and reverse symmetry. It is also desirable for the compensation scheme to provide optimized compensation over a relatively wide range of transmission frequencies. For example, in one embodiment, performance is optimized for frequencies ranging

from 1 MHz to 500 MHz. It is further desirable for the compensation arrangement to take into consideration the phase shifts that occur as a result of the time delays that take place as signals travel between the zones of compensation.

To minimize the effect of phase shift in the compensation
5 arrangement, it is preferred for the second vector 102 to be positioned as close as possible to the first vector 100. In Figure 11, the time delay between the first vector 100 and the second vector 102 is shown as x . In one example embodiment, x can be about 100 picoseconds for a signal having a transmission speed of 3×10^8 meters per second.

10 To maintain forward and reverse symmetry, it is preferred for the time delay between the third vector 104 and the fourth vector 106 to be approximately the same as the time delay between the first vector 100 and the second vector 102. As shown in Figure 11, the time delay between the third and fourth vectors is depicted as x .

15 The time delay y between the second vector 102 and the third vector 104 is preferably selected to optimize the overall compensation effect of the compensation scheme over a relatively wide range of frequencies. By varying the time delay y between the second vector 102 and the third vector 104, the phase angles of the first and second compensation zones are varied thereby altering the
20 amount of compensation provided at different frequencies. In one example embodiment, to design the time delay y , the time delay y is initially set with a value generally equal to x (i.e., the time delay between the first vector 102 and the second vector 104). The system is then tested or simulated to determine if an acceptable level of compensation is provided across the entire signal frequency range intended
25 to be used. If the system meets the near end crosstalk requirements with the value y set equal to x , then no further adjustment of the value y is needed. If the compensation scheme fails the near end crosstalk requirements at higher frequencies, the time delay y can be shortened to improve performance at higher frequencies. If the compensation scheme fails the near end crosstalk requirements at
30 lower frequencies, the time delay y can be increased to improve crosstalk performance for lower frequencies. It will be appreciated that the time delay y can be varied without altering forward and reverse symmetry.

It has been determined that when magnitudes of the second and third vectors 102, 104 are respectively about $-3M$ and about $3M$, the distance y is preferably greater than the distance x to provide optimized crosstalk compensation. However, if the magnitudes of the vectors 102, 104 are reduced below about $-3M$ and about $3M$ (e.g., to approximately $-2.7M$ and $2.7M$), the distance y is preferably less than the distance x to provide optimized crosstalk compensation.

Crosstalk can also be an issue between the 1-2 and 3-6 pairs. Particularly, substantial crosstalk can be generated between track T_2 and track T_3 . As shown at Figure 10, a three-zone compensation arrangement is used to compensate for this crosstalk. The three-zone compensation arrangement includes a first zone of compensation Z_{B1} , a second zone of compensation Z_{B2} and a third zone of compensation Z_{B3} . The first zone of compensation Z_{B1} includes a capacitive coupling $C7$ between track T_1 and track T_3 , and a capacitive coupling $C8$ between track T_2 and track T_6 . The second zone of compensation Z_{B2} includes a capacitive coupling $C9$ between track T_1 and track T_6 . The third zone of compensation Z_{B3} includes a capacitive coupling $C10$ between track T_1 and track T_3 . The three zones of compensation between the 1-2 and 3-6 pairs can be placed at locations consistent with the vector diagram shown in Figure 11, described above.

In general, it has been determined that varying the relative compensation among the pairs at the primary zones of compensation for each pair can affect alien crosstalk. Regarding the zone of compensation Z_{B1} , it has been determined that varying the relative magnitudes of the capacitive couplings $C7$ and $C8$, such that the capacitive couplings are non-equal, can improve overall alien crosstalk of the plug and jack system. In the embodiment shown, a larger capacitance is used for capacitance $C7$ than $C8$, with the overall capacitance relating to the capacitive coupling introduced at the plug, as described above in conjunction with Figure 11.

In general, it has been determined that in zone of compensation Z_{B2} performance is optimized without use of a capacitive coupling between track T_2 and track T_3 . However, in certain embodiments, such a capacitive coupling can be included to preserve symmetry between the pairs. Likewise, in zone Z_{B3} , no capacitive coupling is included between track T_2 and track T_6 , although in symmetric systems such a coupling could be included. Furthermore, it will be

appreciated that the magnitudes of the compensation between the 3-6 and 4-5 pairs are substantially greater in magnitude than those between the 1-2 and 3-6 pairs.

Additional crosstalk exists between the 4-5 and 7-8 pairs. In the embodiment of the crosstalk compensation arrangement shown in Figure 10, a two
5 zone arrangement is used to compensate for crosstalk between those pairs. As shown, the compensation arrangement between the 4-5 and 7-8 pairs is a two zone compensation including a capacitive coupling C11 in a first zone Z_{C1} provided between track T_5 and track T_8 , and capacitive coupling C12 in a second zone Z_{C2} provided between track T_4 and track T_8 .

10 Figure 12 is a schematic vector diagram showing the compensation arrangement used between the 4-5 and 7-8 pairs. As shown at Figure 12, three crosstalk vectors are taken into consideration. The first crosstalk vector 110 is representative of crosstalk generated at the plug. A second vector 112 is representative of crosstalk provided at the first compensation zone Z_{C1} . The third
15 vector 114 is representative of crosstalk generated at the second compensation zone Z_{C2} . The first and third vectors 110, 114 have positive polarities and magnitudes of about N. The second vector 112 has a negative polarity and a magnitude about 2N. Although the disclosed compensation arrangement is asymmetric among the pairs, a symmetric arrangement could be provided as well. Furthermore, it will be
20 appreciated that M (shown at Figure 11) is typically substantially greater in magnitude than N (shown at Figure 12).

As described above, varying the capacitive values across the 4-5 and 7-8 wire pairs used in the first zone of compensation Z_{C1} can improve alien crosstalk values generated from the plug-jack system. In the embodiment shown, a
25 completely unbalanced configuration is selected, such that Z_{C1} includes only compensation between track T_5 and track T_8 , with no corresponding balanced compensation between tracks T_4 and T_7 . In further embodiments, a different, unbalanced arrangement may be selected.

In addition to the multiple zone compensation arrangements
30 described above, a number of single zone compensations can also be used. For example, zone Z_{D1} is a single zone compensation used to compensate for crosstalk generated between the 1-2 and 4-5 pairs, and includes a capacitive coupling C13 provided between track T_2 and track T_5 . Another single zone compensation Z_{E1}

compensates for crosstalk generated between the 3-6 and 7-8 pairs, and is provided by a capacitive coupling C14 formed between track T₃ and track T₇. Other capacitive couplings may be included which compensate for unintended crosstalk generated within the board itself.

5 Again, each of the single zone compensations is illustrated as using an unbalanced arrangement to account for alien crosstalk generated by the plug and jack. It is observed that the “excess” alien crosstalk may be caused, at least in part, by an imbalance in connecting hardware contributing to excess crosstalk between the cables, particularly in short sections of cable between connectors. Therefore,
10 imbalanced compensation across wire pairs can compensate for this excess crosstalk. In the embodiment shown, zone Z_{D1} includes only compensation C13 between track T₂ and track T₅, but no compensation between tracks track T₁ and track T₄. Similarly, zone Z_{E1} includes only compensation C14 between track T₃ and track T₇, but no compensation between tracks track T₆ and track T₈.

15 The crosstalk compensation schemes illustrated herein generally are accomplished by first positioning a crosstalk compensation arrangement relating to crosstalk within the plug and jack, across a variety of wire pairs. In designing the multi-zone crosstalk compensation schemes in accordance with this disclosure, a designer will generally first locate a first zone of capacitive coupling a first time
20 delay away from the capacitive coupling at the plug. The designer can then position a second capacitive coupling, i.e. a second zone of compensation, at a second time delay away from the first time delay. That second zone of compensation can be made up of more than one capacitive coupling, and can have capacitive couplings of differing magnitude. For example, two capacitors can make up a zone of
25 compensation, and can be placed at differing distances from a first zone. An example of such a configuration is illustrated by zone Z_{A2} as described above.

 Once crosstalk for the plug and jack have been brought to an acceptable level using the techniques described above, the compensation arrangement can be altered to improve alien crosstalk. Altering the compensation
30 arrangement is performed to accommodate one or more zones of crosstalk compensation having an asymmetric capacitive coupling between a wire pairs, such that alien crosstalk is reduced. This can be performed by changing the relative magnitudes of the capacitive couplings between wire pairs in one or more of the

zones of compensation. In certain embodiments, a designer can start with a compensation arrangement having symmetric capacitive couplings across complementary wire pairs (e.g. from the 3-6 pair to the 4-5 pair, having equal couplings between T_3 and T_5 and between T_4 and T_6).

5 The various capacitive couplings illustrated in the present disclosure provide an example design for which far end and alien crosstalk are addressed. Additional embodiments exist in which these types of crosstalk are compensated for. In the various embodiments, any amount of asymmetry in any zone of compensation can be introduced to compensate for alien crosstalk, from complete symmetry to
10 complete asymmetry.

In general, the various asymmetric capacitive coupling selections made to account for alien crosstalk are believed to, as a whole, compensate for crosstalk generated in an overall system including both a plug and a contact set of a modular jack, as described above in Figures 4-7. It is particularly notable that the
15 crosstalk compensations selected in the present disclosure may not be symmetric in the sense that equal capacitive couplings are not applied across complementary tracks of a wire pair. Although this may have the effect of slightly worse performance with respect to connector balance and crosstalk within the pair, the net effect of a number of plug and jack systems in close proximity is an improved
20 overall crosstalk compensation.

Figures 13-16 show an example circuit board layout for implementing the compensation arrangement of Figure 10. Figures 14-16 respectively show the front, middle and back conductive layers 140, 142 and 144 of the circuit board 132. Figure 13 is an overlay of the three conductive layers 140,
25 142 and 144. The circuit board 132 defines openings 301-308 that respectively receive posts of the contact springs CS_1 - CS_8 so that the contact springs CS_1 - CS_8 are terminated to the board 132. The circuit board also defines openings 401-408 for respectively receiving posts of the insulation displacement connector blades IDC_1 - IDC_8 such that the insulation displacement connector blades IDC_1 - IDC_8 are
30 terminated to the circuit board. Vias extend through the circuit board for electrically interconnecting the tracks between the layers 140, 142 and 144, and to the various capacitive couplings C1-C13. For example, vias V_{4A} and V_{4B} interconnect the portions of the track T_4 located at the different layers 140, 142 and 144 to the

capacitive couplings C3 and C6. Also, via V₅, interconnects the portions of the track T₅ located at the different layers 140, 142 and 144 to capacitive coupling C5. Moreover, via V₆ interconnects the portions of the track T₆ located at the different layers 140, 142 and 144 with capacitive coupling C6. Likewise, via V₃
5 interconnects the portions of the track T₃ located at the different layers 140, 142 and 144 to capacitive coupling C5.

Referring to Figures 14-16, the capacitive coupling C1 of the first zone of compensation Z_{A1} is provided by opposing capacitor plates C1₅ and C1₃ respectively provided at layers 142 and 144. The capacitive coupling C2 of the first
10 zone of compensation Z_{A1} is provided by opposing capacitor plates C2₄ and C2₆ that are respectively provided at the layers 142 and 144. The capacitive coupling C3 of the second compensation zone Z_{A2} is provided by opposing capacitor plates C3₄ and C3₃ that are respectively provided at layers 142 and 144. The capacitive coupling C4 of the second compensation zone Z_{A2} is provided by opposing capacitor plates
15 C4₆ and C4₅ that are respectively provided at layers 142 and 144. The capacitive coupling C5 of the third compensation zone Z_{A3} is provided by a capacitor plate C5_{5A} that is provided at layer 142. The capacitive coupling C5 is also provided by inter-digitated capacitor fingers C5_{5B} and C5_{3B} that are provided at layer 140. The capacitive coupling C6 of the second compensation zone Z_{A3} is provided by
20 capacitor plate C6_{6A} provided at layer 142. The capacitive coupling C6 is also provided by inter-digitated capacitor fingers C6_{6B} and C6_{4B} provided at layer 140.

The capacitive coupling C7 of the first compensation zone Z_{B1} is provided by opposing capacitor plates C7₁ and C7₃ that are respectively provided at layers 142 and 144 of the circuit board. The capacitive coupling C8 of the first
25 compensation zone Z_{B1} is provided by opposing capacitor plates C8₂ and C8₆ that are respectively provided at the layers 142 and 144 of the circuit board. The capacitive coupling C9 of the second zone of compensation Z_{B2} is provided by opposing capacitor plates C9₁ and C9₆ that are respectively provided at layer 142 and 144 of the circuit board. The capacitive coupling C10 of the third zone of
30 compensation Z_{B3} is provided by opposing capacitor plates C10₁ and C10₃ that are respectively provided at layers 142 and 144 of the circuit board.

The capacitive coupling C11 of the first compensation zone Z_{C1} is provided by opposing capacitor plates C11₅ and C11₈ that are respectively provided

at layers 142 and 144 of the circuit board. The capacitive coupling C12 of the second compensation zone ZC2 is provided by adjacent leads C124 and C128, respectively, located at layer 142. The capacitive coupling C13 of the zone of compensation Z_{D1} is provided by opposing capacitor plates C13₂ and C13₅ provided
5 at layers 142 and 144 of the circuit board. The capacitive coupling C14 of the zone of compensation Z_{E1} is provided by opposing capacitor plates C14₇ and C14₃ respectively provided at layers 142 and 144 of the circuit board.

Various manufacturing and routing techniques may be implemented in the placement of the tracks, vias, and capacitors described herein. Additional
10 details regarding the routing and placement of circuit components are described in U.S. Patent Application No. 11/402,544, filed April 11, 2006, which was previously incorporated by reference in its entirety.

The above specification, examples and data provide a complete description of the manufacture and use of the composition of the invention. Since
15 many embodiments of the invention can be made without departing from the spirit and scope of the invention, the invention resides in the claims hereinafter appended.

Claims:

1. A method for providing crosstalk compensation in a jack, the crosstalk compensation being adapted to compensate for undesired crosstalk generated at a capacitive coupling located at a plug inserted within the jack, the method comprising:

positioning a first capacitive coupling a first time delay away from the capacitive coupling of the plug, the first capacitive coupling having a greater magnitude and an opposite polarity as compared to the capacitive coupling of the plug;

positioning a second capacitive coupling at a second time delay from the first capacitive coupling, the second time delay corresponding to an average time delay that optimizes near end crosstalk, the second capacitive coupling having generally the same overall magnitude but an opposite polarity as compared to the first capacitive coupling, and including two capacitive elements spaced at different time delays from the first capacitive coupling.

2. The method of claim 1, further comprising providing a third capacitive coupling positioned a third time delay away from the second capacitive coupling, such that the third time delay is approximately the same as the first time delay.

3. The method of claim 1, wherein the two capacitive elements connect between wires of a first wire pair and a second wire pair.

4. The method of claim 3, wherein the two capacitive elements connect between different wires of the first wire pair and the second wire pair.

5. The method of claim 1, wherein different time delays of the two capacitive elements in the second capacitive coupling are centered about the average time delay.

6. The method of claim 1, wherein the first capacitive coupling exists across different wire pairs than the second capacitive coupling.

7. A telecommunications jack for use in a twisted pair system, the jack comprising:

- a housing defining a port for receiving a plug;
- a plurality of contact springs adapted to make electrical contact with the plug when the plug is inserted into the port of the housing;
- a plurality of wire termination contacts for terminating wires to the jack;
- a circuit board including conductive tracks that electrically connect the contact springs to the wire termination contacts; and
- a crosstalk compensation arrangement that provides crosstalk compensation between selected tracks of the circuit board, the crosstalk compensation arrangement including a first zone of compensation a first time delay away from the capacitive coupling of the plug and a second zone of compensation at a second time delay from the first zone of compensation, the second zone of compensation including two capacitive elements spaced at different time delays from the first zone of compensation to optimize far end crosstalk and having an average time delay that optimizes near end crosstalk.

8. The telecommunications jack of claim 7, wherein the crosstalk compensation arrangement further includes a third zone of compensation that is positioned a third time delay away from the second zone of compensation, the first and third time delays being generally equal to one another.

9. The telecommunications jack of claim 7, wherein the first zone of compensation has a greater magnitude and an opposite polarity as compared to the capacitive coupling of the plug, and the second zone of compensation has generally the same overall magnitude but an opposite polarity as compared to the first zone of compensation.

10. The telecommunications jack of claim 7, wherein the second zone of compensation is positioned such that the second time delay is greater than the first time delay.

11. The telecommunications jack of claim 7, wherein the second zone of compensation is positioned such that the second time delay is less than the first time delay.

12. A crosstalk compensation system within a telecommunications jack, the system comprising:

a circuit board;

a plurality of contact springs mounted on the circuit board, the contact springs including first, second, third, fourth, fifth, sixth, seventh and eighth consecutively arranged contact springs;

a plurality of wire termination contacts mounted on the circuit board, the wire termination contents including first, second, third, fourth, fifth, sixth, seventh and eighth wire termination contacts for terminating wires to the jack;

a plurality of tracks on the circuit board, the tracks including first, second, third, fourth, fifth, sixth, seventh and eighth tracks that respectively electrically connect the first, second, third, fourth, fifth, sixth, seventh and eighth contact springs to the first, second, third, fourth, fifth, sixth, seventh and eighth wire termination contacts;

a crosstalk compensation arrangement that provides crosstalk compensation between the tracks of the circuit board, the crosstalk compensation arrangement including a first zone of compensation a first time delay away from the contact springs and a second zone of compensation at an second time delay from the first zone of compensation, the second zone of compensation including two capacitive elements spaced at different time delays from the first capacitive coupling and having an average time delay that that optimizes near end crosstalk.

13. The system of claim 12, wherein the second zone of compensation includes a capacitive element connected between the third track and the fourth track.

14. The system of claim 13, wherein the second zone of compensation includes a second capacitive element connected between the fifth track and the sixth track.

15. The system of claim 14, wherein the capacitive element is placed at a time delay further away from the first zone of compensation than the second capacitive element.

16. The system of claim 12, wherein the first zone of compensation includes a capacitive element connected between the third track and the fifth track.

17. The system of claim 12, wherein the first zone of compensation includes a capacitive element connected between the fourth track and the sixth track.

18. The system of claim 12, wherein the crosstalk compensation arrangement includes a third zone of compensation that is positioned a third time delay away from the second zone of compensation, the first and third time delays being generally equal to one another.

19. A method for determining the positions of first and second zones of crosstalk compensation in a jack, the first and second zones of crosstalk compensation being adapted to compensate for undesired crosstalk caused by an undesired capacitive coupling located at a plug inserted within the jack, the first zone of crosstalk compensation including a first capacitive coupling positioned a first time delay away from the undesired capacitive coupling of the plug, the first capacitive coupling having a greater magnitude and an opposite polarity as compared to the undesired capacitive coupling of the plug, the second zone of crosstalk compensation including a second capacitive coupling having two capacitive elements positioned, on average, a second time delay away from the first capacitive coupling, the second capacitive coupling having generally the same magnitude but an opposite polarity as compared to the first capacitive coupling, the method comprising:

positioning the first and second capacitive couplings in initial positions in which the first and second time delays are generally equal to one another;

adjusting the position of the second capacitive coupling from the initial position to an adjusted position to provide improved near end crosstalk compensation;

adjusting the position of the first and second capacitive elements to different lengths to provide improved far end crosstalk compensation while maintaining the adjusted position of the second capacitive coupling as the average position of the first and second capacitive elements.

20. The method of claim 19, further comprising positioning a third zone of compensation a third time delay away from the second zone of compensation, the first and third time delays being generally equal to one another.

21. A method of designing a crosstalk compensation system for a telecommunications jack, the method comprising:

positioning a first zone of crosstalk compensation across at least a first wire pair and a second wire pair on a circuit board within a telecommunications jack, the first zone of crosstalk compensation placed at a first distance from contact springs associated with the first wire pair and the second wire pair;

positioning a second zone of crosstalk compensation across the at least first and second wire pairs at a second distance from the first zone of crosstalk compensation, the second zone of crosstalk compensation including a first capacitive coupling and a second capacitive coupling;

altering the position of the capacitive couplings to establish a distance between the first capacitive coupling and the second capacitive coupling while maintaining the second distance as an average distance from the first zone of crosstalk compensation;

wherein altering the position of the capacitive couplings provides improved far end crosstalk compensation.

22. The method of claim 21, wherein the first and second capacitive couplings connect between different wires of the first wire pair and the second wire pair.

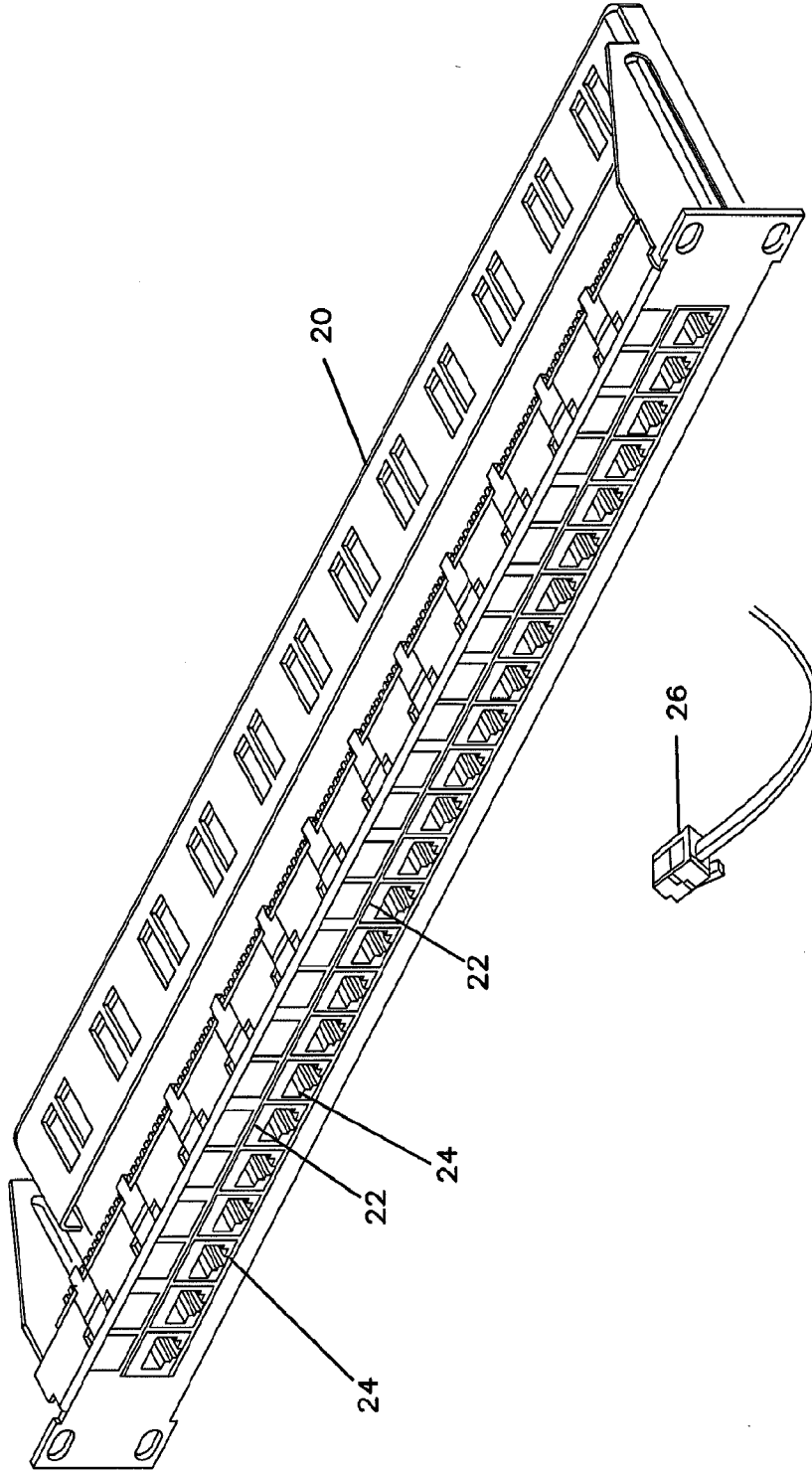

FIG. 1
PRIOR ART

FIG. 2
PRIOR ART

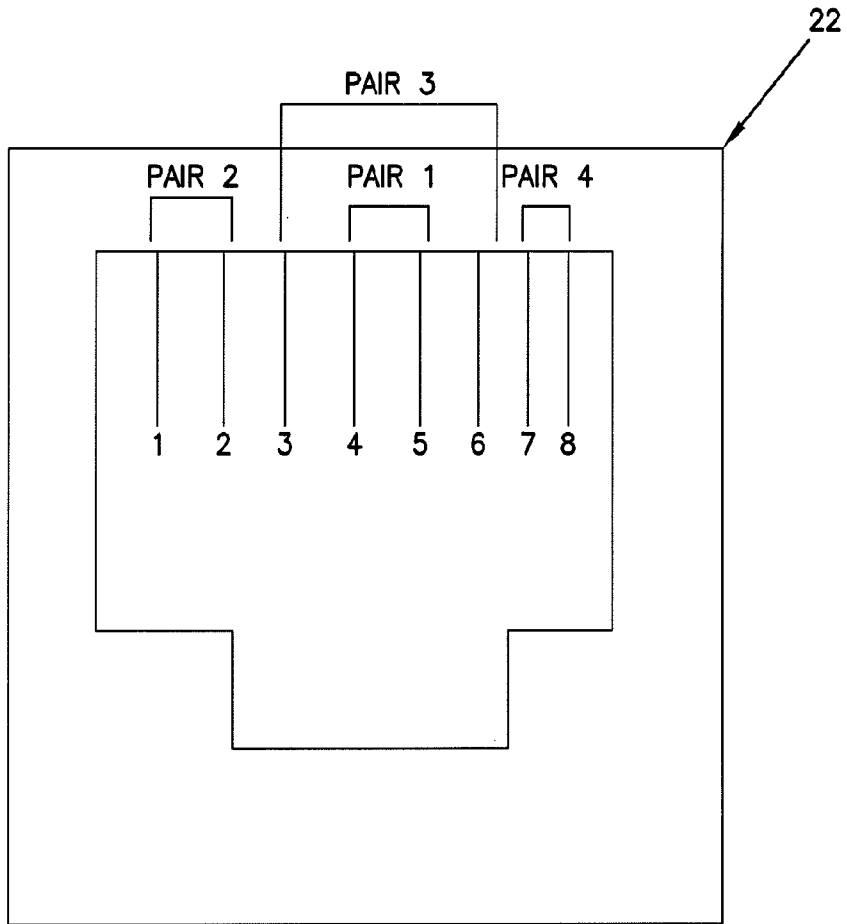

FIG. 3
PRIOR ART

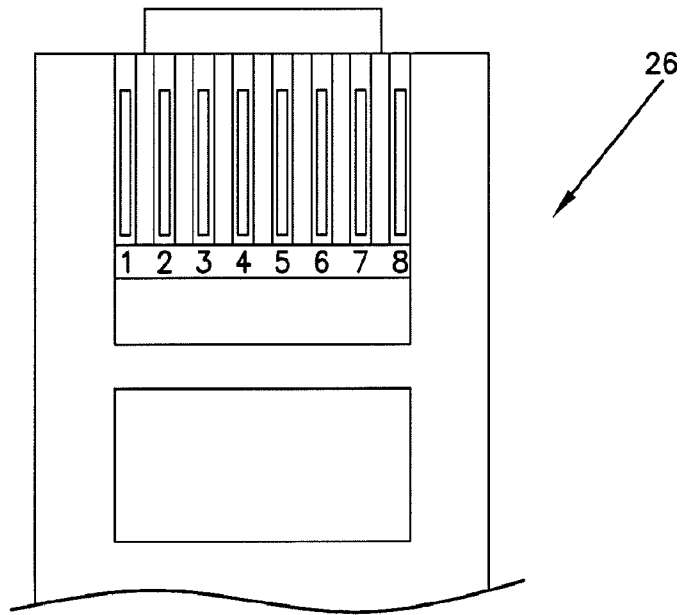

FIG. 4

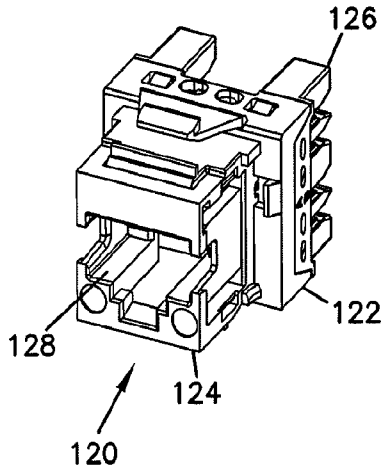

FIG. 5

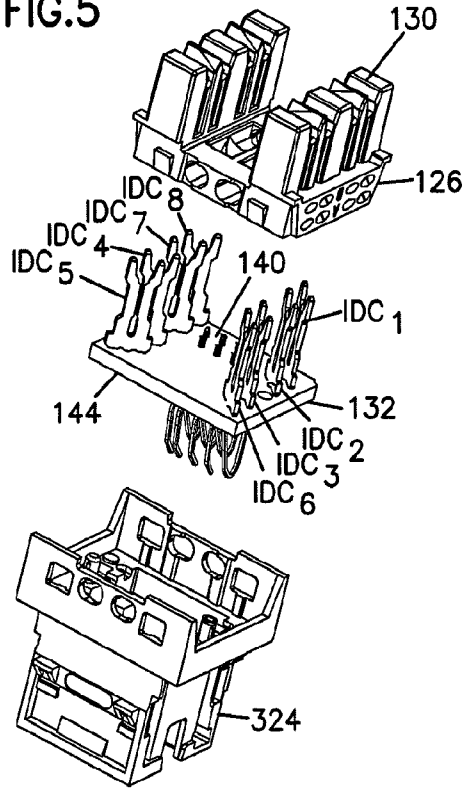

FIG. 6

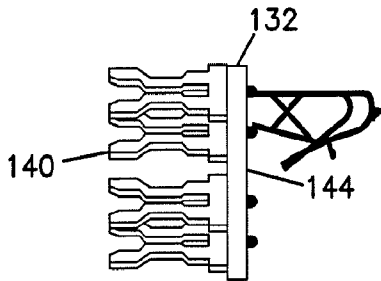

FIG. 7

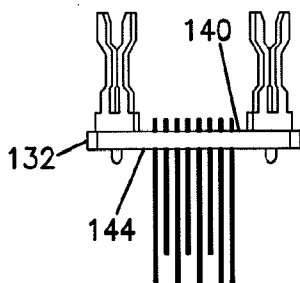

FIG. 8

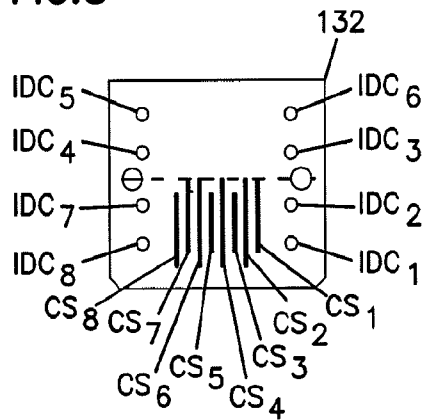

FIG. 9

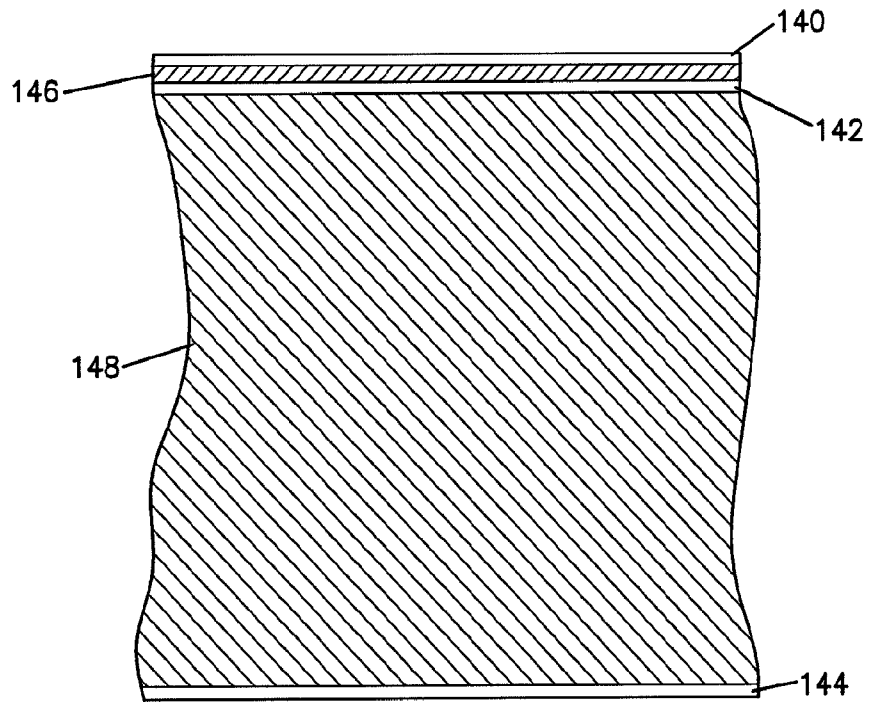

FIG. 10

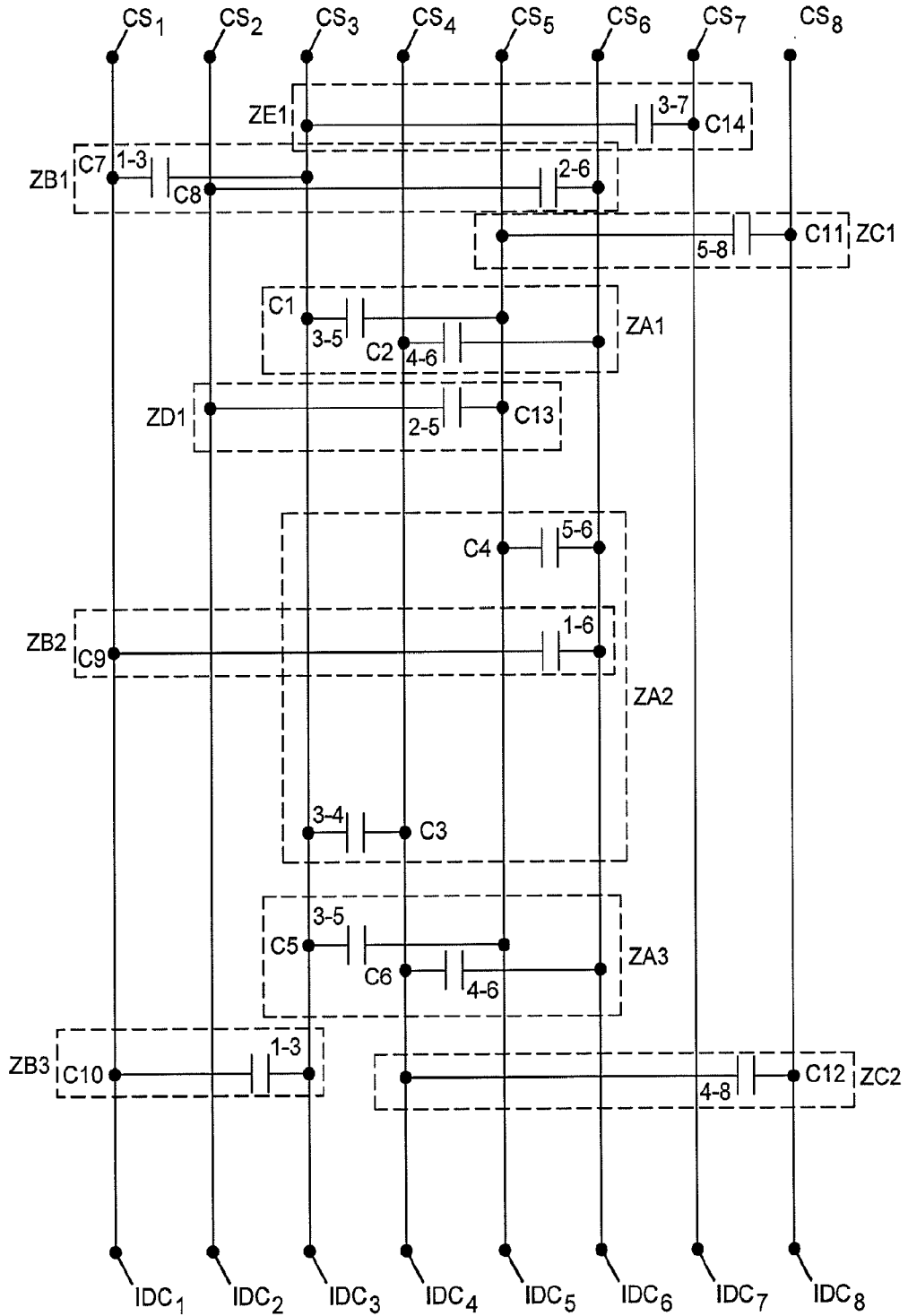
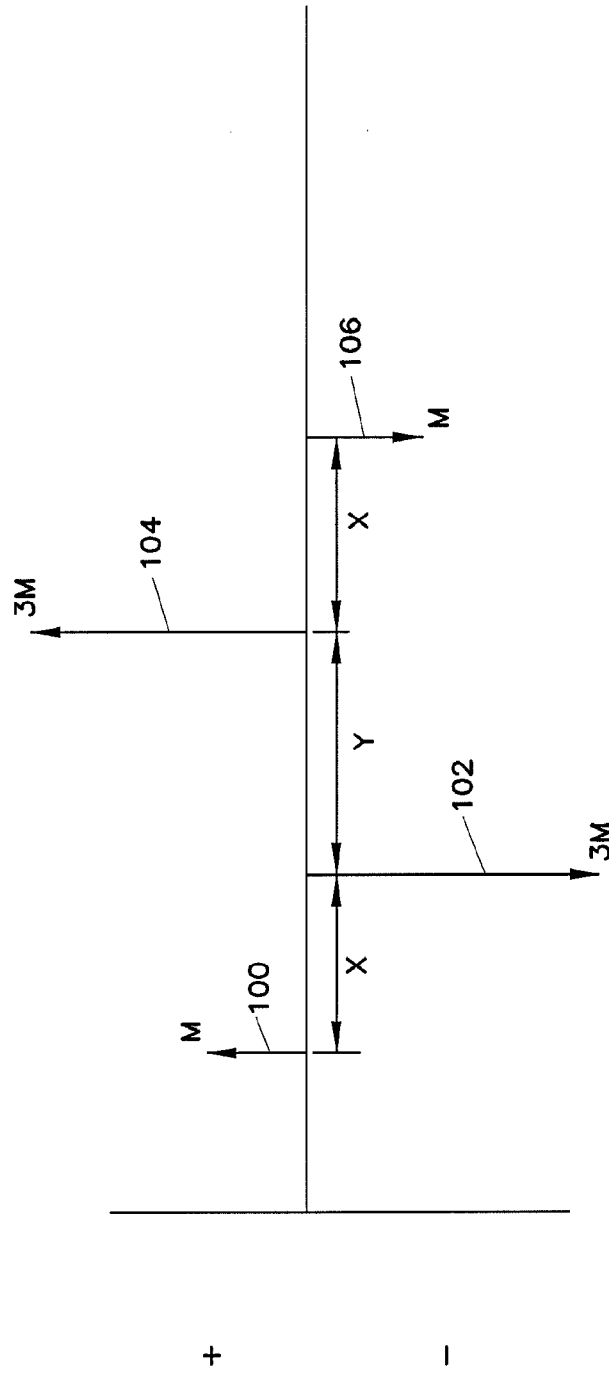

FIG. 11



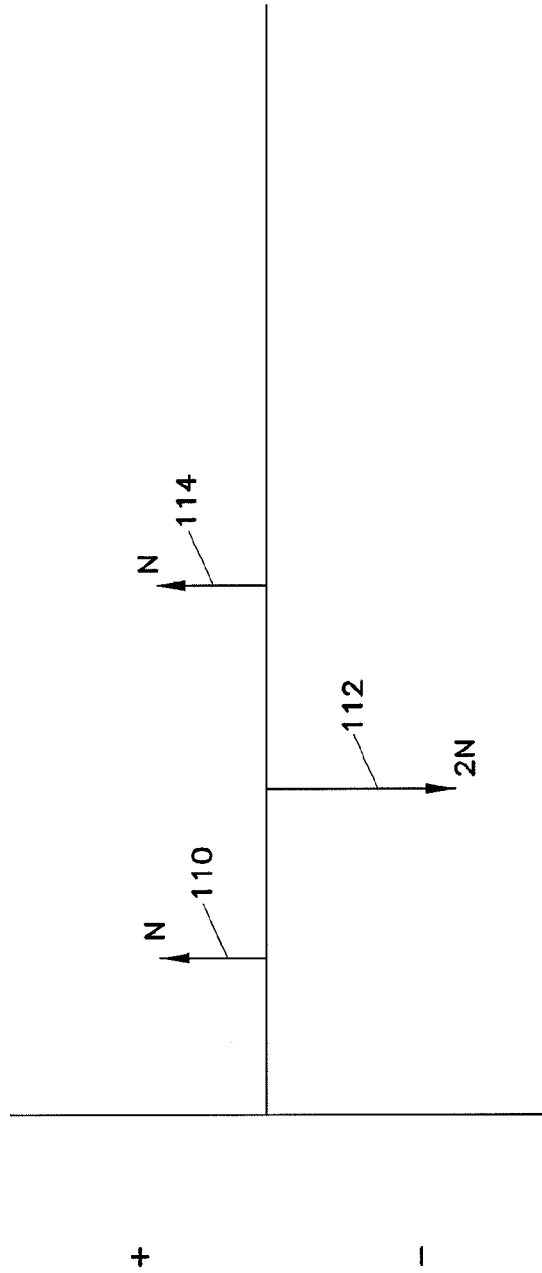

FIG. 12

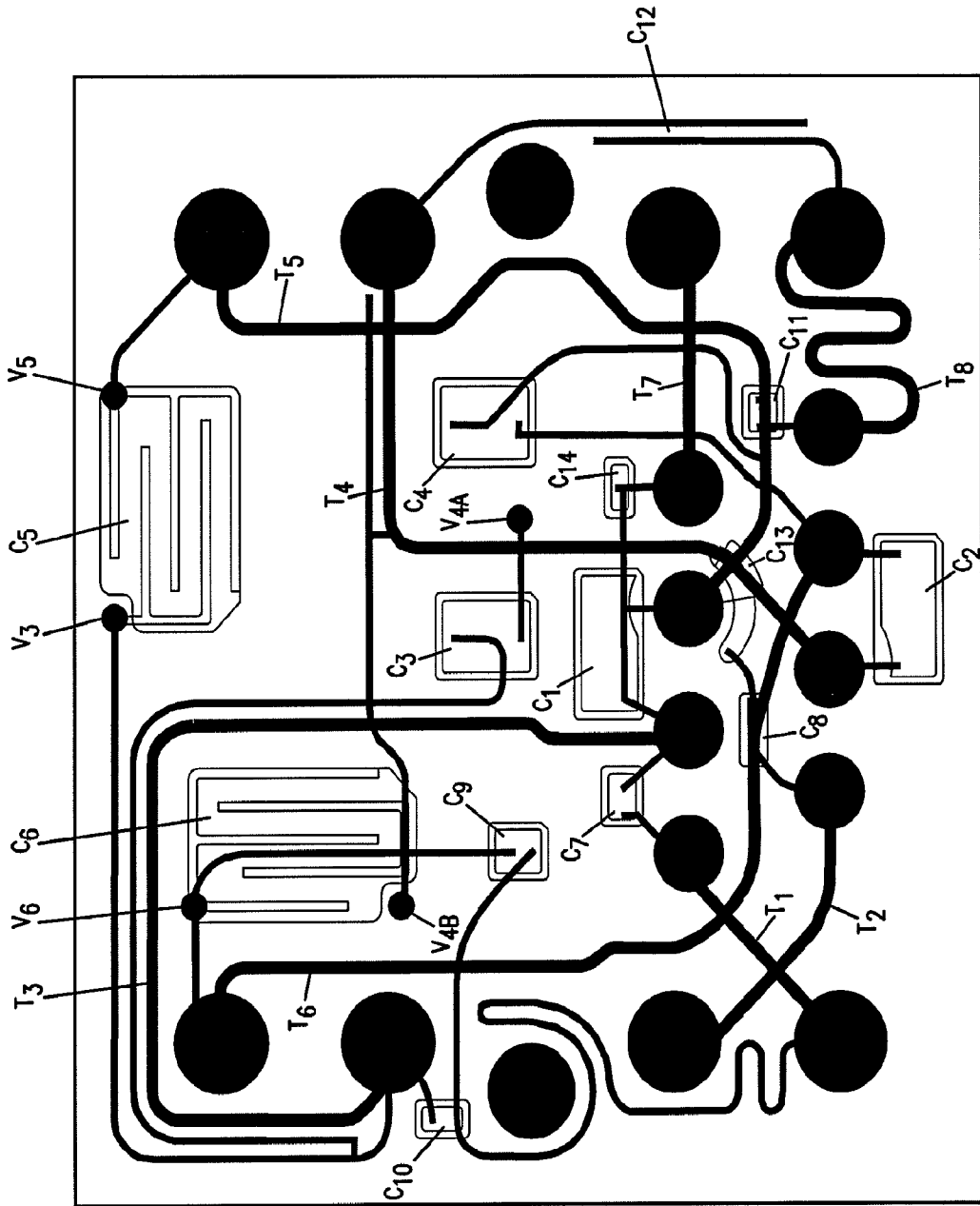

FIG. 13

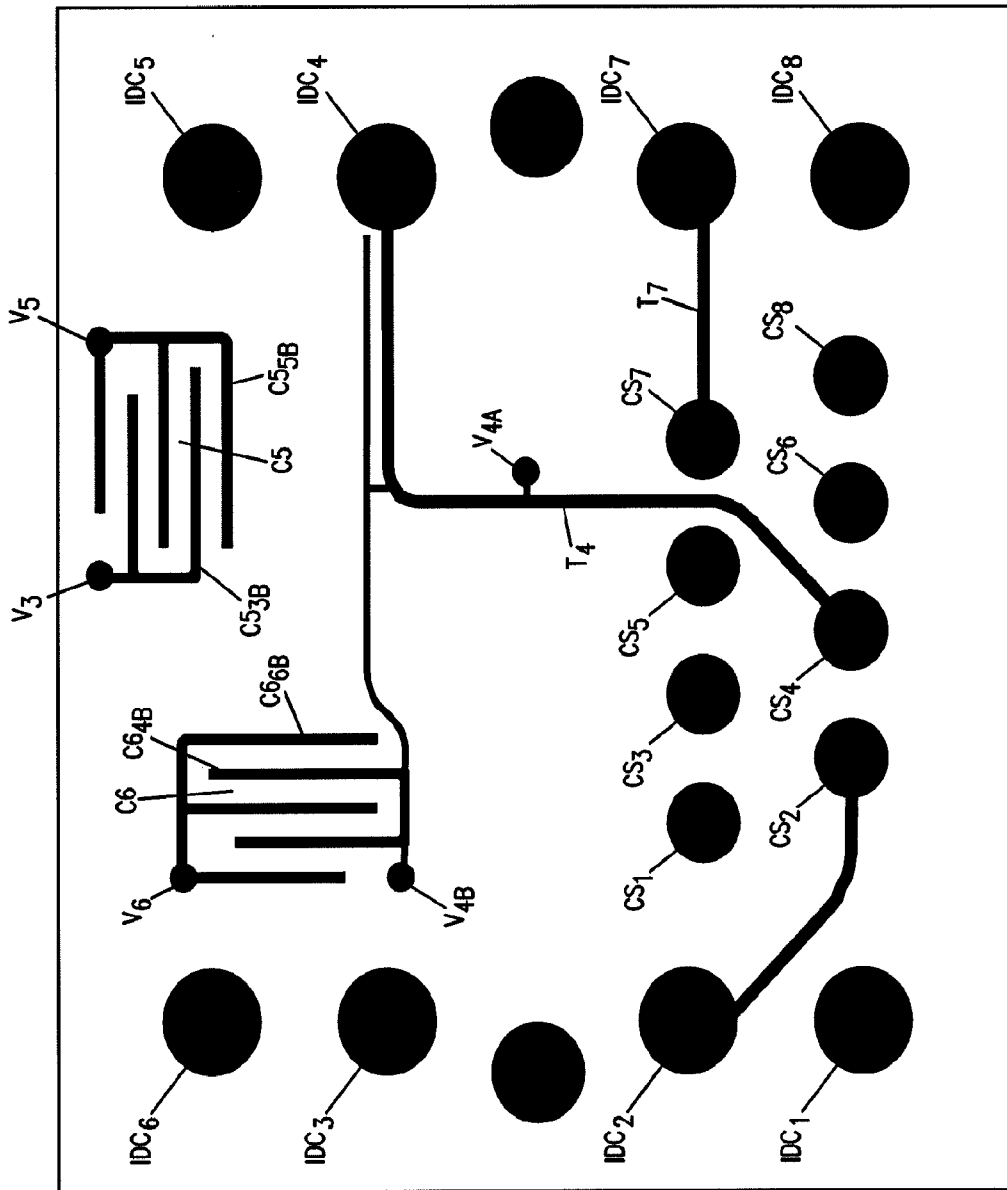

FIG. 14

140

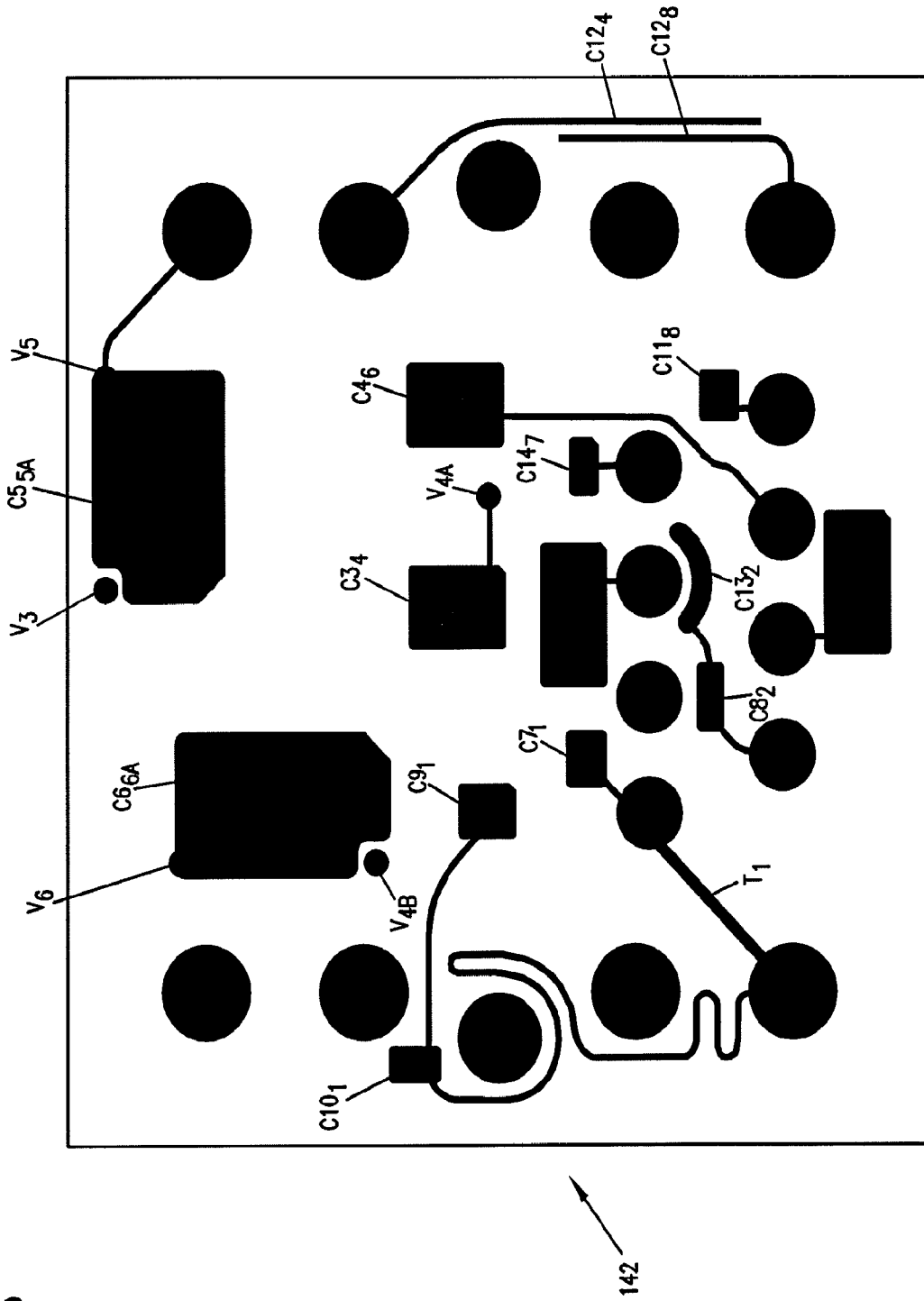

FIG. 15

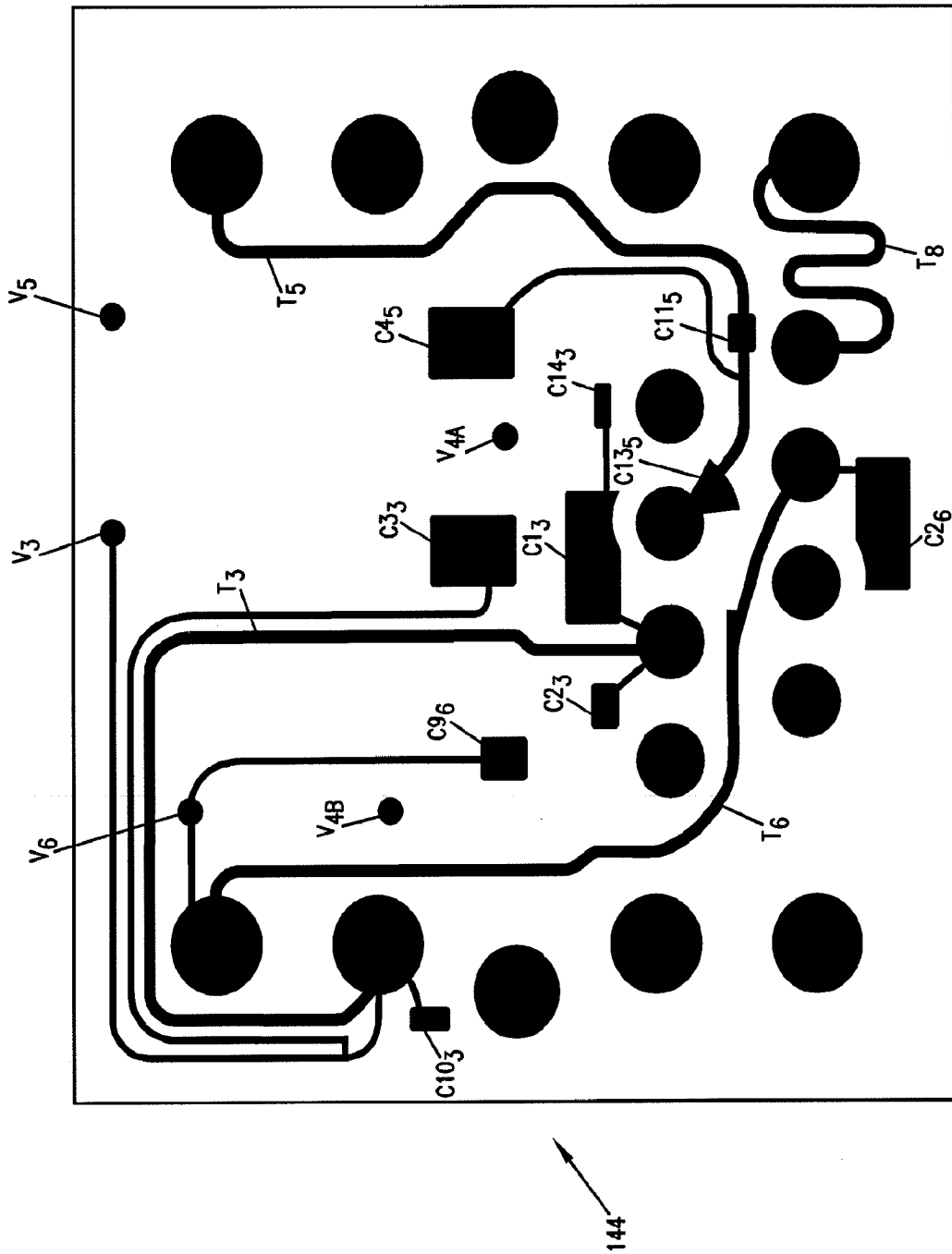

FIG. 16

INTERNATIONAL SEARCH REPORT

International application No
PCT/US2009/033892

A. CLASSIFICATION OF SUBJECT MATTER INV. H01R23/00		
According to International Patent Classification (IPC) or to both national classification and IPC		
B. FIELDS SEARCHED		
Minimum documentation searched (classification system followed by classification symbols) H01R H05K		
Documentation searched other than minimum documentation to the extent that such documents are included in the fields searched		
Electronic data base consulted during the international search (name of data base and, where practical, search terms used) EPO-Internal		
C. DOCUMENTS CONSIDERED TO BE RELEVANT		
Category*	Citation of document, with indication, where appropriate, of the relevant passages	Relevant to claim No.
X	US 2007/238367 A1 (HAMMOND BERNARD H JR [US] ET AL HAMMOND JR BERNARD HAROLD [US] ET AL) 11 October 2007 (2007-10-11) figures 10,11 paragraphs [0039] - [0041], [0047], [0048]	1-22
X	WO 2005/101588 A (PANDUIT CORP [US]; CAVENEY JACK E [US]; BOLOURI-SARANSAR MASUD [US]) 27 October 2005 (2005-10-27) abstract	1-22
A	US 2005/181676 A1 (CAVENEY JACK E [US] ET AL) 18 August 2005 (2005-08-18) abstract	1-22
	----- -/--	
<input checked="" type="checkbox"/> Further documents are listed in the continuation of Box C. <input checked="" type="checkbox"/> See patent family annex.		
* Special categories of cited documents : *A* document defining the general state of the art which is not considered to be of particular relevance *E* earlier document but published on or after the International filing date *L* document which may throw doubts on priority claim(s) or which is cited to establish the publication date of another citation or other special reason (as specified) *O* document referring to an oral disclosure, use, exhibition or other means *P* document published prior to the international filing date but later than the priority date claimed *T* later document published after the international filing date or priority date and not in conflict with the application but cited to understand the principle or theory underlying the invention *X* document of particular relevance; the claimed invention cannot be considered novel or cannot be considered to involve an inventive step when the document is taken alone *Y* document of particular relevance; the claimed invention cannot be considered to involve an inventive step when the document is combined with one or more other such documents, such combination being obvious to a person skilled in the art. *8* document member of the same patent family		
Date of the actual completion of the international search	Date of mailing of the international search report	
26 June 2009	06/07/2009	
Name and mailing address of the ISA/ European Patent Office, P.B. 5818 Patentlaan 2 NL - 2280 HV Rijswijk Tel. (+31-70) 340-2040, Fax: (+31-70) 340-3016	Authorized officer Bernardini, Andrea	

INTERNATIONAL SEARCH REPORT

international application No
PCT/US2009/033892

C(Continuation). DOCUMENTS CONSIDERED TO BE RELEVANT		
Category*	Citation of document, with indication, where appropriate, of the relevant passages	Relevant to claim No.
A	US 2007/238366 A1 (HAMMOND BERNARD H JR [US] ET AL) 11 October 2007 (2007-10-11) abstract -----	1-22
A	US 6 464 541 B1 (HASHIM AMID I [US] ET AL) 15 October 2002 (2002-10-15) abstract -----	1-22
A	EP 0 901 201 A (LUCENT TECHNOLOGIES INC [US]) 10 March 1999 (1999-03-10) abstract -----	1-22

INTERNATIONAL SEARCH REPORT

Information on patent family members

International application No

PCT/US2009/033892

Patent document cited in search report	Publication date	Patent family member(s)	Publication date
US 2007238367 A1	11-10-2007	AU 2007238780 A1	25-10-2007
		CA 2649493 A1	25-10-2007
		CN 101449434 A	03-06-2009
		EP 2008345 A2	31-12-2008
		US 2008261532 A1	23-10-2008
		WO 2007120664 A2	25-10-2007
WO 2005101588 A	27-10-2005	AT 401683 T	15-08-2008
		EP 1738442 A1	03-01-2007
		EP 1953879 A1	06-08-2008
		JP 2007533079 T	15-11-2007
		US 2005277339 A1	15-12-2005
		US 2008242156 A1	02-10-2008
		US 2009130914 A1	21-05-2009
		US 2006286873 A1	21-12-2006
US 2005181676 A1	18-08-2005	AT 413706 T	15-11-2008
		CN 101107753 A	16-01-2008
		EP 1719215 A1	08-11-2006
		EP 2073320 A2	24-06-2009
		JP 2007524207 T	23-08-2007
		US 2009075523 A1	19-03-2009
		US 2007117469 A1	24-05-2007
		WO 2005081369 A1	01-09-2005
US 2007238366 A1	11-10-2007	AU 2007238783 A1	25-10-2007
		CA 2649496 A1	25-10-2007
		EP 2008346 A2	31-12-2008
		WO 2007120667 A2	25-10-2007
US 6464541 B1	15-10-2002	NONE	
EP 0901201 A	10-03-1999	AU 737453 B2	23-08-2001
		AU 8303198 A	18-03-1999
		CA 2245377 A1	02-03-1999
		DE 69800099 D1	27-04-2000
		DE 69800099 T2	14-09-2000
		GR 3033726 T3	31-10-2000
		JP 3356695 B2	16-12-2002
		JP 11233205 A	27-08-1999
		US 5997358 A	07-12-1999