

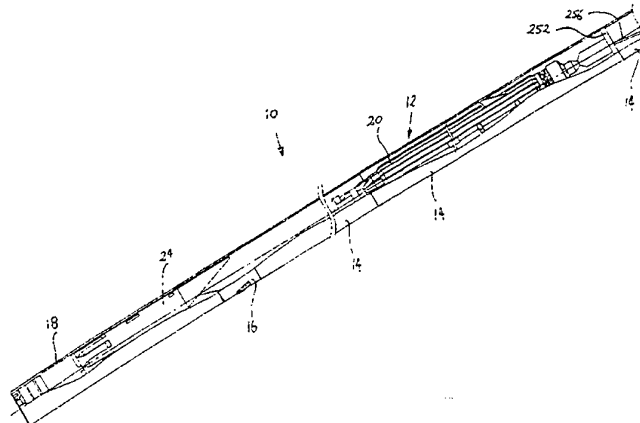

## INTERNATIONAL APPLICATION PUBLISHED UNDER THE PATENT COOPERATION TREATY (PCT)

<p>(51) International Patent Classification<sup>5</sup> : E21B 23/03, 10/66</p>	A1	<p>(11) International Publication Number: <b>WO 94/29567</b></p> <p>(43) International Publication Date: 22 December 1994 (22.12.94)</p>									
<p>(21) International Application Number: PCT/AU94/00322</p> <p>(22) International Filing Date: 15 June 1994 (15.06.94)</p> <p>(30) Priority Data:</p> <table border="0"> <tr> <td>PL 9407</td> <td>16 June 1993 (16.06.93)</td> <td>AU</td> </tr> <tr> <td>PM 4158</td> <td>2 March 1994 (02.03.94)</td> <td>AU</td> </tr> <tr> <td>PM 4159</td> <td>2 March 1994 (02.03.94)</td> <td>AU</td> </tr> </table> <p>(71) Applicant (for all designated States except US): DOWN HOLE TECHNOLOGIES PTY. LTD. [AU/AU]; 38 Coulson Way, Canning Vale, W.A. 6155 (AU).</p> <p>(72) Inventors; and (75) Inventors/Applicants (for US only): MCLEOD, Gavin, Thomas [AU/AU]; 21B Hertford Close, Bullcreek, W.A. 6154 (AU). EGAN, Matthew, Vance [AU/AU]; 21 San Miguel Drive, Leeming, W.A. 6155 (AU).</p> <p>(74) Agent: MIZZI, Anthony, Paul; Griffith Hack &amp; Co., 6th floor, 256 Adelaide Terrace, Perth, W.A. 6000 (AU).</p>		PL 9407	16 June 1993 (16.06.93)	AU	PM 4158	2 March 1994 (02.03.94)	AU	PM 4159	2 March 1994 (02.03.94)	AU	<p>(81) Designated States: AM, AT, AU, BB, BG, BR, BY, CA, CH, CN, CZ, DE, DK, ES, FI, GB, GE, HU, JP, KE, KG, KP, KR, KZ, LK, LU, LV, MD, MG, MN, MW, NL, NO, NZ, PL, PT, RO, RU, SD, SE, SI, SK, TJ, TT, UA, US, UZ, VN, European patent (AT, BE, CH, DE, DK, ES, FR, GB, GR, IE, IT, LU, MC, NL, PT, SE), OAPI patent (BF, BJ, CF, CG, CI, CM, GA, GN, ML, MR, NE, SN, TD, TG).</p> <p>Published With international search report.</p>
PL 9407	16 June 1993 (16.06.93)	AU									
PM 4158	2 March 1994 (02.03.94)	AU									
PM 4159	2 March 1994 (02.03.94)	AU									

(54) Title: SYSTEM FOR IN SITU REPLACEMENT OF CUTTING MEANS FOR A GROUND DRILL



## (57) Abstract

A retractable drill bit system (10) comprises a drive sub (18) which is adapted for connection to a lower end of a drill (12), a tool (20) for installing and retracting drill bit segments (22) from the drive sub (18); and an insert (24) for selectively locking the bit segments (22) to an end of the drive sub (18) and releasing the bit segments (22). A plurality of recesses (5B) are formed about an inner circumferential wall at one end of the drive sub (18) and a landing seat (32) formed about the inner wall upstream of the recesses (58). The area of the interior wall between the landing seat (32) and recesses (58) is profiled with a series of tapered and level surfaces. The tool (20) includes a slidable cradle (176) extending from one end about which the bit segments (22) are held during installation and retrieval. The bit segments (22) being held in place about the cradle by an elastic band (198). The insert (24) is provided at one end with a series of keyways (218) which locate over the bit segments (22) when the bit segments are locked to the drive sub (18). The insert (24) is always retained within the drive sub (18). Bit segments (22) are carried by the tool (20) to the drive sub (18) and locked in place by the insert (24). The tool (20) can then be withdrawn and the drill (12) operated in the normal manner. To retrieve the bit segments (22), the tool (20) is relowered into the drill and then withdrawn a short distance to retract the insert (24) so that the bit segments (22) collapse back onto the cradle (176) and can then be withdrawn from the drill (12).

*FOR THE PURPOSES OF INFORMATION ONLY*

Codes used to identify States party to the PCT on the front pages of pamphlets publishing international applications under the PCT.

AT	Austria	GB	United Kingdom	MR	Mauritania
AU	Australia	GE	Georgia	MW	Malawi
BB	Barbados	GN	Guinea	NE	Niger
BE	Belgium	GR	Greece	NL	Netherlands
BF	Burkina Faso	HU	Hungary	NO	Norway
BG	Bulgaria	IE	Ireland	NZ	New Zealand
BJ	Benin	IT	Italy	PL	Poland
BR	Brazil	JP	Japan	PT	Portugal
BY	Belarus	KE	Kenya	RO	Romania
CA	Canada	KG	Kyrgystan	RU	Russian Federation
CF	Central African Republic	KP	Democratic People's Republic of Korea	SD	Sudan
CG	Congo	KR	Republic of Korea	SE	Sweden
CH	Switzerland	KZ	Kazakhstan	SI	Slovenia
CI	Côte d'Ivoire	LI	Liechtenstein	SK	Slovakia
CM	Cameroon	LK	Sri Lanka	SN	Senegal
CN	China	LU	Luxembourg	TD	Chad
CS	Czechoslovakia	LV	Latvia	TG	Togo
CZ	Czech Republic	MC	Monaco	TJ	Tajikistan
DE	Germany	MD	Republic of Moldova	TT	Trinidad and Tobago
DK	Denmark	MG	Madagascar	UA	Ukraine
ES	Spain	ML	Mali	US	United States of America
FI	Finland	MN	Mongolia	UZ	Uzbekistan
FR	France			VN	Viet Nam
GA	Gabon				

- 1 -

SYSTEM FOR IN SITU REPLACEMENT OF CUTTING MEANS  
FOR A GROUND DRILL

Field of the Invention

5 This invention relates to a system for in situ replacement of cutting means for a ground drill, and in particular, though not exclusively, to a system for the in situ replacement of drill bits and/or reamers of core sampling drills.

Background of the Invention

10 In ground drilling it is customary to detachably fix a drill bit to a lower end of a drill string of a ground drill and rotate the drill string to effect drilling of a hole in the ground by the drill bit. A reamer is usually connected between the lower end of the drill string and the  
15 drill bit to ream the circumferential wall of a hole being drilled. The drill string is formed by screwing individual drill rods together. Drill rods usually come in fixed lengths of 1.5, 3 or 6 metres. As the drill progresses into the ground additional drill rods are screwed into the  
20 upper end drill string.

During drilling it will be necessary to replace the drill bit and reamer either as a result of dulling of the drill bit or due to variations in the sub strata. Although the drill bit must be replaced more often (usually at least six  
25 times more often) than the reamer.

In order to replace a drill bit or reamer the entire drill string must be pulled out of the ground rod by rod, the drill bit replaced, and the drill string reassembled, rod by rod as it is relowered into the ground to continue  
30 drilling. The need to fully withdraw, disassemble and reassemble the drill string when changing the drill bit/reamer is a slow and costly exercise, with the cost

- 2 -

increasing as hole depth increases and the drill string becomes longer.

Several attempts have previously been made to overcome this problem at least insofar as drill bits are concerned by use  
5 of retractable drill bits which releasably engage the lower end of the drill string and can be disengaged and retracted through the drill string for changing while the drill string remains in situ, thereby avoiding the need to withdraw the drill string from the hole. However, these  
10 attempts have not proven to be commercially successful for various reasons including: being extremely complicated in design or application thereby resulting in a large number of failure modes and/or being too costly to manufacture or maintain in an operational state; being prone to fouling  
15 due to drilling fluid and contaminants burring or jamming segments of the drill bit; misalignment of drill bit segments upon engagement with the drill string; reduction in diameter of the core sample due to fixing of the drill bit to an inner tube of the drill string; reduction in  
20 penetration rate; and breaking of individual segments of the drill bit.

#### Summary of the Invention

It is an object of the present invention to provide a system for in situ replacement of drill bits and/or reamers  
25 of a ground drill which attempts to overcome at least one of the above-described deficiencies in the prior art.

According to the present invention there is provided a system for in situ replacement of cutting means of a ground drill where the cutting means is composed of a plurality of  
30 segments, said system comprising:

a tubular member adapted for connection to a lower end of said ground drill, said tubular member provided with seating means formed circumferentially about an inner wall of said tubular member for seating said

- 3 -

segments in a cutting position in which said segments can contact the ground;

5 a tool dimensioned to travel through said ground drill and into said member for transporting said segments to and from said member, said tool being switchable between an installation mode in which segments are loaded onto said tool for installation in said member and a retrieval mode in which said tool is devoid of segments for retrieval of segments previously installed in said member;

10 a substantially cylindrical insert retained in said member, said insert being moveable by said tool between an installation position in which said insert locates said segments in said seating means and retains said segments in said cutting position between said insert and said member and, a retrieval position in which said insert is retracted to release said segments from between said insert and said member, said insert dimensioned to allow said tool to extend therethrough, and said insert and tool adapted to releasably engage each other;

20 whereby, in use, segments installed in the cutting position and retained in said member by said insert can be retrieved by switching said tool to said retrieval mode and lowering said tool into said drill to a position where said tool extends through and engages said insert and pulling said tool upwardly thereby moving said insert to said retrieval position in which said segments can collapse onto and be held on said tool and retrieved by withdrawal of said tool from said drill and, new segments can be installed by switching said tool to said installation mode and lowering said tool into said drill to a position in which said tool extends through and engages said insert wherein further downward movement of said tool moves said insert to said installation position in which said insert locates said segments in said seats and retains said segments in said cutting position between said insert and said member whereafter said tool can be withdrawn to allow drill to proceed.

35

- 4 -

5 Preferably, said tool comprises installation latching means and retrieval latching means for engaging said insert, said installation means being operable and said retrieval latching means being inoperable when said tool is in said installation mode and both said installation and said retrieval latching means being operable when said tool is in said retrieval mode, wherein, said installation means can engage said insert when said tool is lowered into said drill and said retrieval latching means can engage said sleeve when said tool is pulled upwardly a first distance so as to pull said insert upwardly said first distance, said retrieval latching means being disengaged automatically from said insert upon pulling said tool upwardly beyond said first distance.

15 Preferably said tool includes mode selecting means for switching said tool between said installation and retrieval modes, said mode switching means comprising a selector sleeve slidably and rotatably mounted on a body portion of said tool, and provided with installation apertures and retrieval apertures through which said installation latching means and said retrieval latching means can protrude respectively, wherein said selector sleeve can be rotated from a first position corresponding to the installation mode in which said installation apertures over-lie said installation latching means and said retrieval apertures are radially offset relative to said retrieval latching means and, a second position corresponding to said retrieval mode in which said installation apertures and said retrieval apertures over-lie said installation latching means and said retrieval latching means respectively.

Preferably said installation latching means engages said insert by way of abutment with an upper end of said insert.

- 5 -

Preferably said upper end of said insert is profiled in a manner so that when said installation latching means engages said upper end, said tool can be rotated about its longitudinal axis to align said tool with said seating means whereby said segments can be located in said seating means for installation or, collapsed from said seating means onto said tool for retrieval.

Preferably said insert is provided with a first detent for engaging said retrieval latching means and said system further includes means for disengaging said retrieval latching means from said first detent when said tool is pulled upwardly beyond said first distance.

Preferably said disengaging means comprises a tapered surface for compressing said retrieval latching means.

Preferably said tool comprises carrier means onto which said segments can be loaded for carrying said segments to and from said member, and wherein said tool is operable to cause said segments to slide relative to said tool body when said tool engages said insert whereby an upper end of said segments can extend laterally of said tool to engage said seating means and said insert.

Preferably said carrier means comprises a cradle about which said segments are radially spaced, said cradle being slidable relative to a portion of said tool when said tool is in said installation mode and said tool engages said insert, whereby upon relative sliding movement of said cradle and said portion of said tool, said upper end of the segments extend laterally of said tool for engagement by said seating means and said insert.

Preferably said seat comprises a land extending circumferentially about said inner surface of said member whereby, in use, said upper end of said segments when

- 6 -

extending laterally of said tool can engage said land to prevent further downward movement of said segments.

5 Preferably said system further comprises an elastic band surrounding said segments for retaining said segments on said tool, said elastic band acting to bias said segments toward a central longitudinal axis of said member when said segments are retained in said cutting position whereby, during retrieval of said segments, said elastic band assists in collapsing said segments onto said tool.

10 Advantageously said seating means further comprises a series of tapered and flat surfaces formed on said inner circumferential wall of said member.

15 Preferably said cutting means is a drill bit and said segments are bit segments, said bit segments provided with a series of tapered and flat surfaces which face said series of surfaces formed on said member when said bit segments are retained between said insert and said member, each of said series of surfaces configured and juxtaposed so that said bit segments can slide relative to said member when in said cutting position in response to said drill being lifted from and lowered onto the bottom of a hole being drilled by said drill.

25 Preferably, said series of surfaces are further configured and juxtaposed so that a lower end of said bit segments can flex in a radial direction away from said central longitudinal axis of said member to abut said inner circumferential wall of said member when said drill is used as a core sampling drill and lifted from the bottom of said hole to break a core sample.

30 Preferably said cradle comprises an elongate shank extending from a lower tapered end of said body portion of said tool and being slidably housed within a bore in said

- 7 -

body portion, and biasing means acting to retract said shank into said bore, wherein, in said installation mode and prior to engagement of said tool with said insert, said biasing means is held in compression and said shank extends from said bore so that the upper ends of said segments rest on said tapered end and upon engagement of said tool with said insert, said biasing means is released from compression thereby retracting said shank into said bore so that the upper ends of said segments slide along said tapered end to extend laterally of said tool.

Preferably said selector sleeve operates a second detent means for holding said biasing means in compression and wherein said selector sleeve is coupled to said installation latching means so that when said installation latching means engages said insert said selector sleeve slides relative to said tool body to release said second detent means thereby allowing expansion of said biasing means and retraction of said shank into said bore.

In an alternate embodiment, the system can be used for in situ replacement of a reamer of a ground drill where the reamer is composed of a plurality of separate segments. In this embodiment, the cradle comprises a plurality of recesses formed in said tool body, an upper end of each recess provided with a ramp leading to an outer surface of the body and, the selector sleeve being provided with a plurality of apertures which over-lie said segments in both said installation and retrieval modes with a radially inwardly directed lip provided at a lower end of each aperture for abutment with a lower end of each segment, whereby, when said installation latching means engages said insert with the tool in the installation mode, the selector sleeve can slide relative to the tool body so that said lips push said segments and the upper ends of the segments slide along said ramps to extend laterally beyond the tool to engage the seating means and the insert. In this

- 8 -

embodiment, advantageously the seating means comprises a plurality of cut-outs formed radially about said member through which a cutting face of the segments can protrude to effect cutting of the ground.

5 In a further embodiment, a combined system is envisaged for in situ replacement of both a drill bit and a reamer of a ground drill in which the drill bit comprises a plurality of bit segments and the reamer comprises a plurality of reamer segments, the combined system comprising a first  
10 sub-system for replacement of bit segments and a second sub-system for replacement of said reamer segments, each sub-system including a tubular member, tool and insert in accordance with a first aspect of this invention wherein the member of the second sub-system is connected to a lower  
15 end of the drill and the member of the first sub-system is connected to the member of the second sub-system and wherein the tool of the second sub-system is rotatably detachably coupled to an upper end of the tool of the first sub-system so that both the drill bit and reamer can be  
20 replaced simultaneously.

#### **Brief Description of the Drawings**

Embodiments of the present invention will now be described by way of example only, with reference to the accompanying drawings in which:

25 Figure 1 is a side elevation view of a first embodiment of the system disposed within a ground drill;

Figure 2 is a side elevation view of a tool used in the system shown in Figure 1;

30 Figure 3 is a longitudinal section view of the tool shown in Figure 2;

Figure 4a is a side elevation view of a selector sleeve of the tool shown in Figures 2 and 3;

Figure 4b is a end view of the sleeve shown in Figure 4a;

- 9 -

Figure 4c is a view of an opposite end of the sleeve shown in Figure 4a;

Figure 4d is a view of Section B-B shown in Figure 4a;

5 Figure 4e is a view of Section C-C shown in Figure 4a;

Figure 4f is a part view of Section A-A shown in Figure 4b;

10 Figure 4g is a view of Section D-D shown in Figure 4a;

Figure 5a is a side elevation view of an insert used in the system shown in Figure 1;

Figure 5b is a view of one end of the insert shown in Figure 5a;

15 Figure 5c is a view of an opposite end of the insert shown in Figure 5a;

Figure 6a is a longitudinal section view of a member used in the system shown in Figure 1;

20 Figure 6b is a view of one end of the member shown in Figure 6a;

Figure 6c is a view of an opposite end of the member shown in Figure 6a;

Figure 6d is a view of a lower portion of the member shown in Figure 6a;

25 Figure 7a is a side view of a bit segment used in the system shown in Figure 1;

Figure 7b is a top view of the bit segment shown in Figure 6a;

30 Figure 7c is an end view of the bit segment shown in Figures 7a and 7b;

Figure 8a is a top view of a locking clip used in the system shown in Figure 1;

Figure 8b is a side view of the locking clip shown in Figure 6a;

35 Figure 9 is an enlarged partial section view of a lower end of the system;

- 10 -

Figure 10 is a sectional view of an end of the drill in a drilling mode with bit segments locked in a cutting position by the insert;

Figure 11 is a view of the drill string shown in Figure 10 but with the drill string pulled upwardly from a bottom of a hole being drilled;

Figure 12 is a sectional view of a tool used in a second embodiment of the present invention;

Figure 13 is a top view of a reamer segment used in the second embodiment of the invention;

Figure 14 is a partial sectional view of the second embodiment of the invention where the reamer segments are held in a cutting position;

Figure 15 is a side view of a transport sleeve for the system shown in Figure 1.

#### **Detailed Description of the Preferred Embodiments**

Figure 1 illustrates a first embodiment of a system 10 for the in situ replacement of cutting means in the form of a drill bit of a ground drill 12. The drill 12 is composed of a plurality of interconnected drill rods 14 which together form a drill string. A standard reamer 16 for reaming the circumferential wall of a hole being drilled is screwed to the free end of the lowest rod 14.

The system 10 comprises a number of separate but interactive components these including a tubular member taking the form of a drive sub 18 which is adapted for connection to a lower end of the drill 12, an installation and retrieval tool 20 dimensioned to travel through the drill 12 for carrying drill bit segments 22 (refer Figs. 7a, 7b, and 9) to and from the drive sub 18 and, a substantially cylindrical insert 24 which is slidably retained within the member 18 between an installation position in which the insert retains the bit segments 22 in

- 11 -

the drive sub 18 and a retrieval position in which the insert 24 is retracted to allow the bit segments 22 to collapse onto the tool 20 for withdrawal from the drill 12.

Referring to Figures 6a and 6d, it can be seen that the  
5 inner circumferential wall 26 at a lower end 28 of the  
drive sub 18 is provided with seating means 30 for seating  
the bit segments 22. The seating means 30 includes a land  
32 extending circumferentially about the inner surface 26  
followed, in the downstream direction, with a series of  
10 tapered and flat surfaces and recess 58 formed on the  
lowermost one of those surfaces. Specifically, the land 32  
is followed by the following sequence of surfaces in the  
down stream direction: surface 34 tapering away from a  
central longitudinal axis 36 of the drive sub 18; surface  
15 38 extending parallel with axis 36; surface 40 tapering  
toward axis 36; surface 42 tapering away from axis 36;  
surface 44 extending parallel to axis 36; surface 46  
tapering toward axis 36; and surface 48 tapering away from  
axis 36 and extending to the longitudinal extremity 50 of  
20 the drive sub 18. Contiguous with surface 48 is a surface  
52 tapering away from both axis 36 and extremity 50 and  
which leads to outer circumferential surface 54 of the  
drive sub 18.

A plurality of drive lugs 56 are provided on surface 46.  
25 Adjacent drive lugs 56 define the recesses 58 in which a  
lower end of the bit segments 22 are held during drilling.  
As is most evident from Figure 6b, the width of the drive  
lugs 56 reduces in the radial direction toward axis 36. A  
pair of opposed slots 60 extending parallel to axis 36 are  
30 machined in wall 26 inboard of the ends of the drive sub  
18. A locking clip 62 (refer Figures 8a and 8b) is  
inserted into an upper end 64 of each slot 60. A lower end  
of each locking clip is formed with a surface 65 tapering  
toward the inner wall 26 and a spring clip 66 attached near

- 12 -

an upper end of the clip on a surface opposite the inner wall 26.

As explained with reference to Figures 7a and 7b, the bit segments 22 are configured for mating with the seating means 30 of the drive sub 18. The bit segments comprise a shank 68 and a crown 70 formed at a lower end of the shank 68 for engaging and cutting the ground. The crown 70 typically comprises a matrix of diamonds and metal. In use, as ground engaging face 72 of the crown wears away fresh diamonds are exposed to facilitate cutting.

Side 74 (shown uppermost in Figure 7b) of the bit segments 22 faces the inner surface 26 of the drive sub 18. The side 74 of shank 68 comprises the following sequence of surfaces starting from crown 70 (the axis 36 is shown in phantom for convenient reference in Figure 7a); surface 76 tapering toward axis 36; surface 77 extending parallel to axis 36; surface 78 tapering away from axis 36; surface 80 tapering toward axis 36; level surface 82 extending parallel to axis 36; surface 84 tapering away from axis 36; surface 86 tapering toward axis 36; surface 88 extending parallel to axis 36. Surface 88 is followed by an abrupt step 90 which leads to surface 92 tapering toward axis 36 and extending to extremity 94 of the shank 68.

Opposite side 96 of shank 68 comprises the following sequence of surfaces in the direction from extremity 94 to crown 70: surface 98 tapering toward axis 36; level surface 100 extending parallel to axis 36; surface 102 tapering toward axis 36; and level surface 104 extending parallel to axis 36.

As shown most clearly in Figure 7c, the crown 70 is in the shape of a sector of an annulus and formed with inner and outer arcuate faces 106 and 108 respectively, with the length of face 108 being greater than that of face 106.

- 13 -

The face of the crown 70 opposite cutting face 72 is provided with the following sequence of surfaces in the direction from outer face 108 to outer face 106: surface 110 extending parallel to cutting face 72; surface 112 inclined toward cutting face 72 and terminating adjacent surface 76 of shank 68; and surface 114 tapering away from cutting face 72 and terminating at arcuate face 106. Surfaces 112 and 76 form a V-shaped recess 116 which can engage the services 48 and 52 of the drive sub 18 (as seen in Figure 10).

Referring to Figures 2-4f, the tool 20 comprises a main body portion 118 upon which a selector sleeve 120 is slidably and rotatably retained. An upper end 122 of body 118 is provided with a screw thread for attaching a standard wire line adaptor 124. A pair of opposing longitudinal grooves (not shown) are machined in body 118 at end 122 for slidably retaining a ring 126. The ring is provided on its inner circumferential surface with a pair of protrusions (not shown) which ride in the grooves to allow the ring 126 to slide longitudinally of the body 118. A spring 128 retained between the wire line adaptor 124 and ring 126 acts to bias the ring 126 and sleeve 120 away from end 122. A protrusion 130 is formed on an end of ring 126 adjacent the sleeve 120 for engagement in one of the two mode selector recesses 132, 134 cut in an adjacent end of the sleeve 120.

Body 118 is provided with an internal cavity 136 which houses a pair of installation latch dogs 138. Pin 140 extends through one end of both latch dogs 138 and couples the body 118 to the sleeve 120. The pin 140 resides in a longitudinal slot (not shown) formed in the body 118 and a transversely extending slot 142 formed in the sleeve 120. Each end of pin 140 sits on a lip 143 formed about the periphery of slots 142. This provides a connection between

- 14 -

body 118 and sleeve 120 where the sleeve can slide longitudinally and rotate relative to the body 118.

A second pin 144 extends parallel to pin 140 and resides in a longitudinal slot 148 formed in the body 118. Spring 150  
5 connects opposite ends of latch dogs 138 to the pin 144. The spring 150 biases the latch dogs 138 so as to extend laterally of body 118 and through apertures or slots 139 (refer Figs. 4A, 4D) cut in sleeve 120. Each latch dog 138 is provided with a bearing face 152 for abutment with the  
10 insert 24.

A pair of retrieval latch dogs 154 similar to the insertion latch dogs 138 is also provided in the tool 20 on a side of the latch dogs 138 opposite end 122. However, the retrieval latch dogs 154 are located in a plane disposed  
15 perpendicular to that containing the insertion latch dogs 138. In addition, the retrieval latch dogs are orientated in an opposite sense to the insertion latch dogs 138. That is, ends 156 of retrieval latch dogs 154 are biased by a spring (not shown) to extend laterally of the body 118 and  
20 through apertures or slots 155 (refer Figures 4a, 4e) cut in sleeve 120 with opposite ends 158 being held by a pin 160 extending through the body 118. Bearing faces 162 are formed at ends 156 of the retrieval latch dogs 154 for engaging the insert 24.

25 As is most evident from Figures 4d and 4e, the installation latch dog slots 139 are wider than the retrieval latch dog slots 155.

A rectangular cavity 164 is formed in the body 118 adjacent the retrieval latch dogs 154. Extending longitudinally of  
30 one end 166 of the cavity 164 is a hole 168 which communicates with cylindrical recess 170. Recess 170 extends through a frusto-conical shaped end 172 of the body 118. The cavity 164, hole 168 and recess 170 collectively

- 15 -

form a slideway 174 for a cradle 176 upon which the bit segments 22 are attained.

The cradle 176 comprises a central bar 178 from which coaxially extends at one end a threaded stem 180 and terminates at an opposite end in a stop 182. The stem 180 extends through recess 170 and hole 168 into cavity 164. The end of the bar 178 adjacent the stem 168 is slidably received in recess 170. A spring 184 is retained on the stem 180 between a tension adjustment nut 186 screwed onto the stem 180 and end 166 of the cavity 164. Opposite ends 188 and 190 of the nut 186, are tapered or bevelled so as to reduce in thickness radially away from the centre of the nut 168.

A pair of locking pins (not shown) reside in respective recesses 192 formed in the body 118. The pins are retained within their respective recesses 192 by the sleeve 120 and have an end which can be selectively extended into and retracted from the recess 164 by virtue of relative movement of the sleeve 120. Referring to Figure 4f, an inner circumferential wall 194 of the sleeve 120 is provided with a circumferential groove 196. When the sleeve 20 is positioned so that the groove 196 overlies the recesses 192, the ends of the pins therein can be retracted from the cavity 164 to allow extension of spring 184. However, the ends of the pins are held to extend into the cavity 164 by abutment of the pins with wall 194 when the sleeve 120 is positioned so that the groove 196 does not overlie the recesses 192. Under this condition, the pins abut against nut 186 maintaining the spring 184 in compression.

When loading the tool 20 to install the bit segments 22, the segments are disposed radially about the bar 178 with crowns 70 abutting the stop 182. Surface 98 of each bit segment 22 rests on the large diameter end of frusto-

- 16 -

conical end 172 for the body 118. An elastic band 198 encircles the bit segments 22 about respective surfaces 82 to hold the bit segments onto the cradle 176.

5 A plurality of ridges 200 are provided on the outside surface of sleeve 120 extending parallel to the length of the sleeve 120. The ridges 200 are evenly spaced, with adjacent ridges defining shallow channels 202 through which a fluid can flow when the tool 20 is lowered through the drill 12.

10 Insert 24 (refer Figs. 5a-5c) is provided in the system 10 for expanding the bit segments 22 against the bias of elastic band 198 and locating the bit segments 22 into a cutting or drilling position against the inner surface of drive sub 18.

15 The insert 24 is in the form of a cylindrical tube having a pair of opposing peaks 206 extending from an upstream end 204. The sides of each peak slope sharply in the downstream direction and lead to flats 208 which separate the peaks 206. A pair of longitudinally extending rails  
20 210 protrude from the outer circumferential surface 212 of insert 24. The rails 210 ride in the slots 60 in the drive sub 18. A pair of opposed detents in the form of longitudinally extending slots 214 (only one shown) are cut into the insert 24 for engaging the retrieval latch dogs  
25 154. An upstream end of each slot 214 is bevelled so as to slope toward an inner surface of the insert 214 in the upstream direction. The end of the sleeve 24 opposite peaks 206 is provided with a plurality of longitudinally extending keyways 218. Adjacent keyways 218 are spaced  
30 apart by lugs 220. Waterways 222 are machined along the length of the inner surface of insert 24. The waterways provide a flow path for water used in bit cooling, lubrication and flushing.

- 17 -

A tool 20' (refer Figure 12) for replacing reamer segments (refer Figs. 13 and 14) is structurally and functionally equivalent to the tool 20 used for replacement of drill bit segments 22. Accordingly, the reference numbers used in relation to the description of the tool 20 are also employed to denote similar features in the tool 20'. A wireline adaptor 124' is screwed onto upper end 122 of the tool 20'. Spring 128' interposes the wireline adaptor 124' and ring 126'. As with tool 20, the ring 126' is able to slide longitudinally of the tool 20' as provided with a protrusion 130 for engaging recesses (not shown) cut in an upper end of sleeve 120'. Installation and retrieval latch dogs 138' and 154' are identical to those of tool 20. The essential differences between tool 20' and tool 20 are that the cradle 176' comprises a plurality of cut-outs 227 formed radially about a lower end of body 118'. An upper end of each cut-out is provided with a ramp 228 which leads to the outer surface of body 118'. In addition, sleeve 120' is provided with a plurality of apertures 230 which overlie the cut-outs 227. A radially inwardly directed lip 232 is provided at the lower end of each aperture 230.

A further difference between tools 20 and 224 is the length of the slots in which the pins of the installation and retrieval latch dogs are retained. Specifically, the slots in tool 20' (see for example slot 148') are much longer than those of the corresponding slots in tool 20.

A standard overshot attachment 234 is connected to the lower end of tool 224 for connection with the wireline adaptor 124 of tool 20. This connection allows the tools 20 and 20' to rotate relative to each other.

Reamer segments 226 are retained in cut-outs 227 when being installed in or retrieved from the drill 12. Reamer segments 226 are in the shape of a rectangular prism having inclined sides. Each segment 226 is mounted on a

- 18 -

rectangular plate 236. Upstanding lips 238 and 240 extend across the upstream and downstream ends of the plate 326 respectively. Both lip 240 and the upstream end of the plate 236 are bevelled so as to converge toward each other  
5 in the upstream direction.

The segments 226 are retained in cut-outs 227 by rubber bands 242 and 244 which encircle plates 236 adjacent the ends of the corresponding segments 226.

A tubular member in the form of an auxiliary drive sub 18' is screwed onto the drill for holding the reamer segments  
10 226 in a cutting position. Auxiliary drive sub 18' is provided with seating means comprising a land 32' protruding inwardly from an inner circumferential wall of drive sub 18' and cut-outs 246 (only one shown) having  
15 bevelled edges 248 for seating the bit segments 226. A recess 250 is cut into the inner surface of the drive sub 18 adjacent the downstream end of each cut-out 246 for accommodating the lips 238.

Auxiliary insert 24' is retained with auxiliary drive sub  
20 18 for selectively holding the segments 226 in a cutting position and releasing the segments 226 for replacement. Insert 24' is essentially the same as insert 24 with the exception that it does not include the keyways 218 and lugs 220 of insert 24. Tool 20' is used to slide the insert 24'  
25 between an installation position in which the insert 24' locates and retains the segments 226 in the cutting position and, a retrieval position in which the insert 24' is retracted to release the segments so that they can collapse back onto the tool 226 by action of the elastic  
30 bands 242 and 244.

Referring again to Figure 1, the ground drill 12 is in this embodiment a core sampling drill such as for example, of the type manufactured by LONGYEAR. Core sampling drills

- 19 -

typically include a landing ring 252 retained in a lower end of the drill 12. The landing ring 252 is used to halt the passage of a conventional core sample barrel 254 (refer Figures 10 and 11). The top of the core sample barrel 254 rests on the landing ring 252 preventing the core sample barrel 254 from falling out of the drill 12. The core sample barrel 254 is used to collect and retain a core sample of the ground being drilled. Once the core sample barrel is filled, drilling is stopped, the drill lifted from the bottom of the hole being drilled to break the core sample, then the core sample barrel lifted up through the drill 12 by a wire line 256.

When the system 10 is used for in situ replacement of a drill bit only, then the conventional core sampling drill bit (not shown) is replaced with drive sub 18 which threadingly engages reamer 16. In the event that the system 10 is also to be used to allow in situ replacement of the reamer, then the standard reamer 16 is also removed and replaced with drive sub 18'. Inserts 24 and/or 24' are always retained within corresponding drive subs 18 and 18'. Tools 20 and 20' are lowered and retrieved from the drill 12 for installing and retrieving bit segments 22 and 226 respectively. When tools 20 and 20' are removed, standard core sample barrel 254 can then be lowered into the drill 12 which passes through the inserts 24 and 24' for receiving a core sample.

The method of operation of the system 10 will now be described in connection with the replacement of drill bit segments.

The drive sub 18 is screwed onto the reamer 16 of a standard core sampling drill. Tool 20 is set to the installation mode by turning sleeve 120 relative to ring 126 so that the protrusion 130 engages installation mode selector recess 132. Cradle 176 is extended from body 118 compressing the spring 184 which is held in compression by

- 20 -

locking pins (not shown) having ends extending into the cavity 164. In this configuration, the installation latch dogs 138 extend laterally from slots 139 in the sleeve 120. However, the retrieval latch dogs 154 are not aligned with slots 155 and are therefore held in a compressed state within the confines of sleeve 120. Bit segments 22 are loaded onto the cradle 176 and held in place by elastic band 198 which contacts the surface 82 of each bit segment 22. Crown 70 of each bit segment abuts stop 182. The insert 24 is disposed within the drive sub 18 and held above the seating means 30 by clip 62. The insert 24 is orientated so that peaks 206 point in the upstream direction. Rails 210 of the insert 24 ride in slots 60 to allow the insert 24 to slide along the inside of the drive sub 18.

Tool 20 is connected to a standard wire line overshot via the wireline adaptor 124 and inserted into transport sleeve 260 (shown in Figure 15) which compresses the installation latch dogs 138. Transport sleeve 260 together with tool 20 is then lowered through the centre of the drill 12. Transport sleeve dead weight 262 (refer Figure 16) can be attached to an upper end of sleeve 260 to increase the rate of decent of tool 20. The decent of the transport sleeve 260 is halted by abutment with the landing ring 252. However, the tool 20 which has an outer diameter smaller than the inner diameter of the ring 252 continues its decent. As the tool 20 passes through landing ring 252, the installation latch dogs 138 are biased by spring 150 to extend from slots 139 formed in sleeve 120. Bearing faces 152 of latch dogs 138 contact peaks 206 causing the tool 20 to rotate until a position is reached where the bearing faces 152 reside on flats 208 separating the peaks 206. The rotation of the tool 20 ensures correct alignment of bit segments 22 with recesses 56 of the drive sub 18 and keyways 218 of the insert 24.

- 21 -

The latch dogs 138 are driven backward a short distance upon impacting with peaks 206 causing a corresponding movement in the sleeve 120. This action results in the groove 196 being located over recesses 192 so that the pins (not shown) residing therein are retracted from cavity 164 allowing spring 184 to expand. This in turn causes the cradle 176 to retract into the body 118. Surface 98 of each bit segment slides along the frusto-conical end 172 to extend laterally of the body 118 and contact inner wall 22 (refer Figure 9). As tool 120 continues its descent, the step 90 of shanks 68 engage the land 32 on the drive sub 18.

The continued downward movement of the tool 120 also draws insert 24 downwards by virtue of the installation latch dogs 138 bearing on flats 208. When step 90 of each bit engages land 32 further downward movement of the bit segments 22 is prevented. The insert 24 collects the backside 96 of the bit segments and acts to expand the bit segments 22 outwardly in the radial direction against the bias of elastic band 198 locating the bit segments into separate recesses 58. The insert 24 continues to move downwardly until it reaches the installation position in which its keyways 218 slide over the bit segments 22 to retain the bit segments between the drive sub 18. Elastic band 198 resides in a cavity formed between surface 44 of the drive sub 18 and surface 82 of the bit segments 22.

Tool 20 can then be withdrawn via the wireline 256 to the landing ring 252 upon which, installation latch dogs 138 are compressed by being drawn backwards through ring 252. Tool 20 then re-enters the transport sleeve 260 and both are completely withdrawn from the drill 12.

The bit segments 22 locked about the drive sub 18 form a drill bit for cutting the ground. Standard core sample barrel 254 can then be lowered into the drill 12 via wire

- 22 -

line 256 for holding a core sample of the ground being drilled. Insert 24 is dimensioned to allow the core sample barrel 254 (refer Figs. 10 and 11) to pass therethrough.

5 With the bit segments 22 retained between drive sub 18 and insert 24 so as to form a drill bit, the drill 12 is lowered to the bottom of the bore hole being drilled and rotated to recommence drilling. Referring to Figure 10 as the bit crowns 70 touch the bottom of the hole, bit segments 22 are forced to slide backward with surfaces 34, 10 48 and 52 of the drive sub bearing against surfaces 86, 112, and 114 of the bit segments respectively. In this mode, (drilling mode) steps 90 are spaced above the land 32. The sliding motion of the bit segments is facilitated by surfaces 77 and 88 of the bit segments, and surface 38 15 of the drive sub, all of which extend parallel to axis 36.

The arrangement of surfaces on the bit segments 22 and drive sub 18 transfers the bit weight and internal/external rotational forces created during drilling to the drive sub 18. Furthermore, this action locks the insert 24 in place 20 by means of a clamping action as the uppermost inside edge of each bit segment is forced slightly inwardly, against the outer circumferential wall 212 of the insert 24.

The transfer of forces during drilling between the bit segments 22 and drive sub 18 are also shown in Figure 10 25 and are described hereinafter. Arrow A shows the direction of transference of a portion of the string weight from the bit crown 70 to the drive sub 18 during drilling. This force is directed in the longitudinal direction of drive sub 18 and is applied to surfaces 48 and 52. The remainder 30 of string weight is transmitted through surface 86 of each bit segment to surface 34 of each keyway as shown by Arrow F in Figure 10. This force also causes the bit segments 22 to move radially inwards so as to provide the clamping action against insert 24 required during drilling.

- 23 -

External radial forces acting on face 108 of crowns 70 transferred to the drive sub by surface 52 as shown by arrow B. These forces are also borne by surfaces 52 and 48 of the drive sub 18. Internal radial forces on the bit crown 70 and drive lugs 56 are transferred to the drive sub via surface 48 as indicated by arrow C.

During core breaking (shown in Figure 11) when the drill 12 is lifted from the bottom of the borehole, the bit segments slide relative to the drive sub 18 until steps 90 abut land 32, with surfaces 40 and 46 of the drive sub bearing against surfaces 84 and 78 of the bit segments respectively. The core sample barrel 254 also exerts a force against surface 102 of the bit segments 22. This force is transmitted in a diagonal direction inclined toward the bottom of the bore hole from the bit segments 22 to the drive sub 18 between respective surface pairs 77 and 46; and, 84 and 40 as shown by arrows D, E and G.

A space or gap between surfaces 78 and 46 on the bit segments 22 and drive sub 18 respectively (shown in Figure 10) allows the bit segments 22 to flex radially outwardly when the core sample barrel 254 exerts a force on the bit segments 22 during core breaking. This spreads the bit segments radially away from axis 36 during core breaking and allows the core sample to be broken from the rock formation being drilled in the conventional manner via a core sample barrel lifter (not shown).

During drilling, as explained above, the insert 24 locks the bit segments 22 in place by a clamping action as the upper most inside edge of each bit segment is forced slightly inwardly against the outer circumferential wall 212 of insert 24.

- 24 -

Rotational drive is rotated from the drive sub 18 to the bit segments 22 via drive lugs 56.

Bit lubrication and cooling is provided in the conventional manner with fluid being pumped into the drill 12 and  
5 channelled via internal waterways 222 of insert 24 which allows the fluid to reach the bit crown 70. However, cooling at the bit crown 70 is substantially different to that achieved with standard drill bits. Extremely wide waterways are automatically provided in the present system  
10 10 by the gaps formed between adjacent bit segments 22.

In conventional drill bits, relatively narrow channels or grooves are cut in the crown to allow for the passage of lubricating and cooling fluid. The gaps between the bit segments 22 in the present embodiment, represent an  
15 increase of between 300% to 600% of the waterway width in comparison with standard drill bits. Conversely, there is a substantial reduction in the surface area of the bit crown 70. This is contrary to standard practice of bit matrix design. It is believed that the present arrangement  
20 of drill bit segments provides more efficient cutting as cooling, flushing of contaminants, and lubrication is achieved more efficiently and at lower pump pressures. The crown design also affords an increased penetration rate by virtue of the concentration of the drill weight onto a  
25 smaller cutting area. The extra wide waterways between adjacent bit segments also negate the problem of bit waterway blockage and lost circulation caused by burring of the bit crown or contamination by drill cuttings.

To retrieve and replace bit segments 22, the drill 12 is  
30 initially lifted a short distance off the bottom of the hole so as to break a core sample from rock formation 264. The core sample barrel 254 is then removed from the drill by use of wireline 256 in the conventional manner.

- 25 -

Tool 20 is placed into the retrieval mode by means of a counter-twist of sleeve 120 so that the retrieval recess 134 engages protrusion 130. This results in slots 155 being aligned with the retrieval latch dogs 154 which  
5 become fully expanded and extend beyond the surface of sleeve 120. The tool 20 is inserted into transport sleeve 260 and lowered through the drill 12. Upon reaching the landing ring 252, the descent of sleeve 260 is halted but the tool 20 continues through the landing ring 252 exposing  
10 the retrieval and installation latch dogs 138, 154 which contact inner circumferential wall of the drill 12.

Tool 20 then enters the insert 24 and in doing so results in the retrieval latch dogs being compressed by contact with the inner circumferential wall of the insert 24. The  
15 installation latch dogs 138 contact peaks 206, rotating the tool into correct alignment in the drive sub 18. As the installation latch dogs 138 bottom out on the flats 208, the retrieval latch dogs 154 expand into slots 214 provided in the insert 24. Cradle 176 is in an extended position  
20 with spring 184 compressed and nut 186 locked against linear movement by the locking pins (not shown) residing in recesses 192. Cradle 176 is disposed centrally of the bit segments 22 with stop 182 extending beyond the bit crowns 70. As the tool 20 is now lifted a short distance by a  
25 wireline 256, the retrieval latch dogs 154 draw back the insert 24 which slides along slots 60 in drive sub 18. Simultaneously, the bit segments 22 are released and collapse onto cradle 176 by contraction of the elastic bands 198. Upon further upward pulling of the tool 20 the  
30 retrieval latch dogs 154 are disengaged automatically from insert 24 by being compressed by tapered surfaces 65 on the clip 62.

As the tool continues its upward movement, it leaves the insert 24 and both the retrieval latch dogs and  
35 installation latch dogs contact the inner circumferential

- 26 -

wall of the drill 12. On reaching the landing ring 252, the installation latch dogs are compressed against the bias of spring 150 so as to pass through ring 252. In order to compress the retrieval latch dogs 154, the faces 162 together with the lower end face of landing ring 252 are provided with bevelled or tapers so that an abutment of the retrieval latch dogs with the landing ring, the application of an upward force will result in the retrieval latch dogs being compressed so as to pass through the landing ring 252.

The tool 20 then re-enters the transport sleeve 260 and together therewith is pulled to the surface. The bit segments 22 can then be removed from the cradle 176 and new drill bits can be attached hereto for installation on the drive sub 18.

In situ replacement of the reamer segments 226 by interaction of the reamer tool 20', auxiliary drive sub 18' and auxiliary insert 24' is essentially identical to that described above with reference to the bit segments 22. The only substantive difference between the two being in the operation of the cradle 176'. Referring to Figure 2, reamer segments 226 are placed within the recesses 227 of cradle 176. When installation latch dogs 138 impact on the peaks of insert 24', sleeve 120' is forced backward, that is in the upstream direction. Accordingly, lips 232 on the sleeve 120' abut lips 238 of plate 236. This causes the reamer segments 226 to slide along ramps 228 so that lip 240 extends laterally of the outer surface of sleeve 120'. In this way, lip 240 can then contact land 32' to halt further downward movement of the reamer segments 226. Retrieval of the reamer segments is achieved in the same manner as for the bit segments.

When it is desired to incorporate replaceable reamer segments in the drill 12, the standard reamer 16 is

- 27 -

replaced with drive sub 18'. The reamer segments 226 typically would be changed simultaneously with drill bit segments 22 by connecting the wireline overshot 234 of tool 20' with the wireline adaptor 124 of tool 20. This allows  
5 relative rotation of tools 20 and 20'. While reamer segment and bit segment replacement would occur simultaneously, the reamer segments would not be replaced as often as the bit segments. When the reamer segments are not being replaced, tool 20' is left in the installation  
10 mode and no reamer segments 226 are loaded onto the cradle 176'.

It is apparent from the above description that the present invention enjoys numerous advantages and benefits over the prior art. Most importantly, it allows easy and very quick  
15 replacement of the drill bit and reamer without the need to withdraw the string from the hole, thereby reducing downtime, increasing productivity, and reducing drilling costs. The ease and simplicity of changing the drill bit also encourages the changing of drill bits in conjunction  
20 with variations in sub-strata in order to optimise bit hardness and characteristics with the sub-strata encountered. In this regard, it is known for drill bits to be completely worn when drilling through sub-strata of a depth of less than 1 meter when that drill bit is not  
25 specifically designed for the sub-strata encountered. In addition, the unique shape and configuration of the drill bits in conjunction with the keyways of the drive sub and configuration of the insert performs the following major functions:

- 30 1. The tapered surfaces on the bit segments and drive sub transmit the load forces experienced on the bit crown during lifting of the drill string to break and retrieve the core sample evenly throughout the drive sub 18 thereby negating the  
35 possibility of snapping the bit segments 22.

- 28 -

2. The surfaces on side 74 of bit segments 22 in conjunction with the drive lugs 56 and insert 24, transmit the string weight and rotational torque experienced during drilling, evenly throughout the entire drive sub assembly.  
5
3. The surfaces of the drive sub 18 and bit segments allows the bit segments to slide between the drive sub 18 and insert 24 when the drilling operation changes from drilling mode to core breaking mode which provides for easy snap-over locking and unlocking of the bit segments during installation and retrieval.  
10
4. The surfaces of the drive sub 18 and the base of the bit crown 70 also serves to counteract the internal/external radial forces experienced by the bit crown during drill rotation.  
15
5. The sliding and non-tight fit of the bit segments into the drive sub allows ease of insertion and retraction. This also negates problems associated with contamination of parts with drilling fluid or cuttings.  
20
6. The use of mating tapered surfaces instead of threads allows for maximum design strength along the full length of each bit segment 22 to get a very robust and simple bit segment design.  
25
7. The back and forth movement provided for in the design of the drive sub 18, and experienced when the drill is lifted off the bottom of the borehole, or engages the bottom of the borehole, automatically and continually defouls the bit segments. It will also automatically correct any jamming of bit segments, caused by contamination  
30

- 29 -

of the like which may occur in drill certain formations.

- 5           8.           The interaction between the surfaces of the bit segment and keyways also automatically lock the insert 24 in the drilling mode the moment the bit crown 70 touches the bottom of the borehole, and releases the insert the moment the drill sting is lifted off the bottom of the borehole.

**THE CLAIMS DEFINING THE INVENTION ARE AS FOLLOWS:**

1. A system for in situ replacement of cutting means of a ground drill where the cutting means is composed of a plurality of segments, said system comprising:

5           a tubular member adapted for connection to a lower end of said ground drill, said tubular member provided with seating means formed circumferentially about an inner wall of said tubular member for seating said segments in a cutting position in which said segments can  
10           contact the ground;

          a tool dimensioned to travel through said ground drill and into said member for transporting said segments to and from said member, said tool being switchable between an installation mode in which segments are loaded onto said  
15           tool for installation in said member and a retrieval mode in which said tool is devoid of segments for retrieval of segments previously installed in said member;

          a substantially cylindrical insert retained in said member, said insert being moveable by said tool  
20           between an installation position in which said insert locates said segments in said seating means and retains said segments in said cutting position between said insert and said member and, a retrieval position in which said insert is retracted to release said segments from between  
25           said insert and said member, said insert dimensioned to allow said tool to extend therethrough, and said insert and tool adapted to releasably engage each other;

          whereby, in use, segments installed in the cutting position and retained in said member by said insert  
30           can be retrieved by switching said tool to said retrieval mode and lowering said tool into said drill to a position where said tool extends through and engages said insert and pulling said tool upwardly thereby moving said insert to said retrieval position in which said segments can collapse  
35           onto and be held on said tool and retrieved by withdrawal of said tool from said drill and, new segments can be

- 31 -

installed by switching said tool to said installation mode and lowering said tool into said drill to a position in which said tool extends through and engages said insert wherein further downward movement of said tool moves said insert to said installation position in which said insert locates said segments in said seating means and retains said segments in said cutting position between said insert and said member whereafter said tool can be withdrawn to allow drill to proceed.

10                   2. A system according to claim 1, wherein said tool comprises installation latching means and retrieval latching means for engaging said insert, said installation means being operable and said retrieval latching means being inoperable when said tool is in said installation mode and both said installation and said retrieval latching means being operable when said tool is in said retrieval mode, wherein, said installation means can engage said insert when said tool is lowered into said drill and said retrieval latching means can engage said sleeve when said tool is pulled upwardly a first distance so as to pull said insert upwardly, said retrieval latching means being disengaged automatically from said insert upon pulling said tool upwardly beyond said first distance.

25                   3. A system according to claim 2, wherein said tool includes mode selecting means for switching said tool between said installation and retrieval modes, said mode switching means comprising a selector sleeve slidably and rotatably mounted on a body portion of said tool, and provided with installation apertures and retrieval apertures through which said installation latching means and said retrieval latching means can protrude respectively, wherein said selector sleeve can be rotated from a first position corresponding to the installation mode in which said installation apertures over-lie said installation latching means and said retrieval apertures

- 32 -

are radially offset relative to said retrieval latching means and, a second position corresponding to said retrieval mode in which said installation apertures and said retrieval apertures over-lie said installation latching means and said retrieval latching means respectively.

4. A system according to claim 3, wherein said installation latching means engages said insert by way of abutment with an upper end of said insert.

10 5. A system according to claim 4, wherein said upper end of said insert is profiled in a manner so that when said installation latching means engages said upper end, said tool can be rotated about its longitudinal axis to align said tool with said seating means whereby said segments can be located in said seating means for installation or collapsed from said seating means onto said tool for retrieval.

20 6. A system according to claim 5, wherein said insert is provided with a first detent for engaging said retrieval latching means and said system further includes means for disengaging said retrieval latching means from said first detent when said tool is pulled upwardly beyond said first distance.

25 7. A system according to claim 6, wherein said disengaging means comprises a tapered surface for compressing said retrieval latching means.

30 8. A system according to claim 7, wherein said tool comprises carrier means onto which said segments can be loaded for carrying said segments to and from said member, and wherein said tool is operable to cause said segments to slide relative to said tool body when said tool engages said insert whereby an upper end of said segments

- 33 -

can extend laterally of said tool to engage said seating means and said insert.

5 9. A system according to claim 8, wherein said carrier means comprises a cradle about which said segments are radially spaced, said cradle being slidable relative to a portion of said tool when said tool is in said installation mode and said tool engages said insert, whereby upon relative sliding movement of said cradle and said portion of said tool, said upper end of the segments extend laterally of said tool for engagement by said seating means and said insert.

10 10. A system according to claim 9, said seat comprises a land extending circumferentially about said inner surface of said member whereby, in use, said upper end of said segments when extending laterally of said tool can engage said land to prevent further downward movement of said segments.

15 11. A system according to claim 10, further comprising an elastic band surrounding said segments for retaining said segments on said tool, said elastic band acting to bias said segments toward a central longitudinal axis of said member when said segments are retained in said cutting position whereby, during retrieval of said segments, said elastic band assists in collapsing said segments onto said tool.

20 12. A system according to claim 11, wherein said seating means further comprises a series of tapered and level surfaces formed on said inner circumferential wall of said member.

25 30 13. A system according to claim 12, wherein said cutting means is a drill bit and said segments are bit segments, said bit segments provided with a series of

- 34 -

tapered and level surfaces which face said series of surfaces formed on said member when said bit segments are retained between said insert and said member, each of said series of surfaces configured and juxtaposed so that said bit segments can slide relative to said member when in said cutting position in response to said drill being lifted from and lowered onto the bottom of a hole being drilled by said drill.

14. A system according to claim 13, wherein said series of surfaces are further configured and juxtaposed so that a lower end of said bit segments can flex in a radial direction away from said central longitudinal axis of said member to abut said inner circumferential wall of said member when said drill is used as a core sampling drill and lifted from the bottom of said hole to break a core sample.

15. A system according to claim 14, wherein each segment includes a crown having a cutting face for bearing against and cutting said ground and an opposing face on which a plurality of said series of surfaces of each bit segment are formed, and a lower end of said member is configured to mate with said opposing face when said ground drill is in use drilling a hole and supported by said segments, whereby, in use, forces acting radially inwardly on said bit crowns are transferred to said member through the mating surfaces of said opposing face and lower end of said member.

16. A system according to claim 15, wherein said series of surfaces are further configured and juxtaposed so that an upper end of said bit segments are biased radially inwardly when said ground drill is in use drilling a hole, thereby acting to clamp against said insert.

17. A system according to claim 10, wherein said cradle comprises an elongate shank extending from a lower

- 35 -

tapered end of said body portion of said tool and being slidably housed within a slideway in said body portion, and biasing means acting to retract said shank into said slideway, wherein, in said installation mode and prior to  
5 engagement of said tool with said insert, said biasing means is held in compression and said shank extends from said slideway so that the upper ends of said segments rest on said tapered end and upon engagement of said tool with said insert, said biasing means is released from  
10 compression thereby retracting said shank into said slideway so that the upper ends of said segments slide along said tapered end to extend laterally of said tool.

18. A system according to claim 17, wherein said selector sleeve operates a second detent means for holding  
15 said biasing means in compression and wherein said selector sleeve is coupled to said installation latching means so that when said installation latching means engages said insert said selector sleeve slides relative to said tool body to release said second detent means thereby allowing  
20 expansion of said biasing means and retraction of said shank into said slideway.

19. A system according to claim 8, wherein said cradle comprises a plurality of recesses formed in said tool body, an upper end of each recess provided with a ramp  
25 leading to an outer surface of the body and, the selector sleeve being provided with a plurality of apertures which over-lie said segments in both said installation and retrieval modes with a radially inwardly directed lip provided at a lower end of each aperture for abutment with  
30 a lower end of each segment, whereby, when said installation latching means engages said insert with the tool in the installation mode, the selector sleeve can slide relative to the tool body so that said lips push said segments and the upper ends of the segments slide along

- 36 -

said ramps to extend laterally beyond the tool to engage the seating means and the insert.

20. A system according to claim 19, wherein said seating means comprises a plurality of cut-outs formed radially about said member through which a cutting face of the segments can protrude to effect cutting of the ground.

21. A system according to claim 20, wherein said cutting means is a reamer composed of a plurality of said segments.

22. A system for the combined in situ replacement of a drill bit and reamer of a ground drill in which the drill bit comprises a plurality of bit segments and the reamer comprises a plurality of reamer segments, the combined system comprising a first sub-system for replacement of bit segments and a second sub-system for replacement of said reamer segments, each sub-system including a tubular member, tool and insert in accordance with claim 1, wherein the member of the second sub-system is connected to a lower end of said drill and the member of the first sub-system is connected to the member of the second sub-system and wherein the tool of the second sub-system is rotatably detachably coupled to an upper end of the tool of the first sub-system whereby, in use, both the drill bit and reamer can be replaced simultaneously.

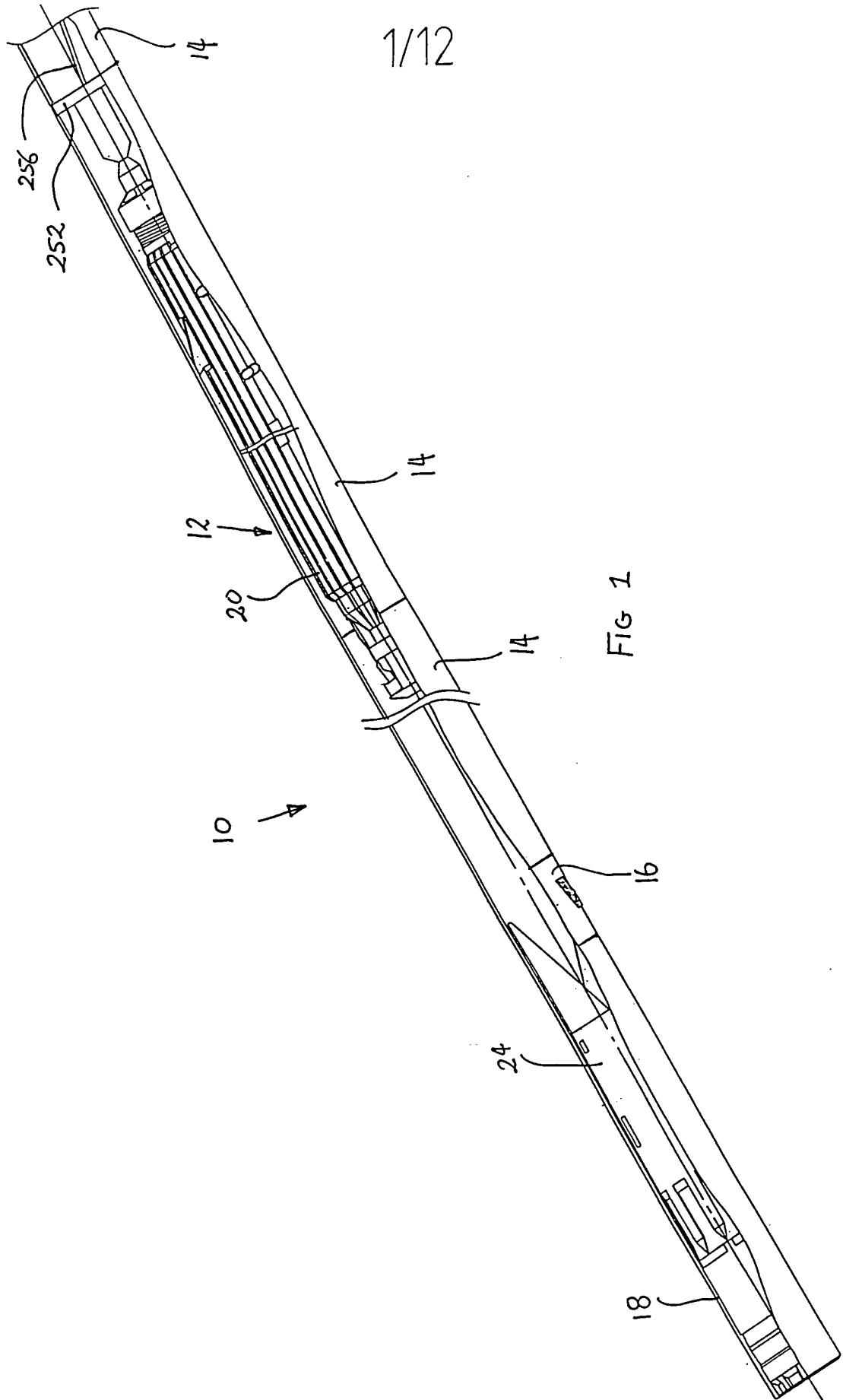



3/12

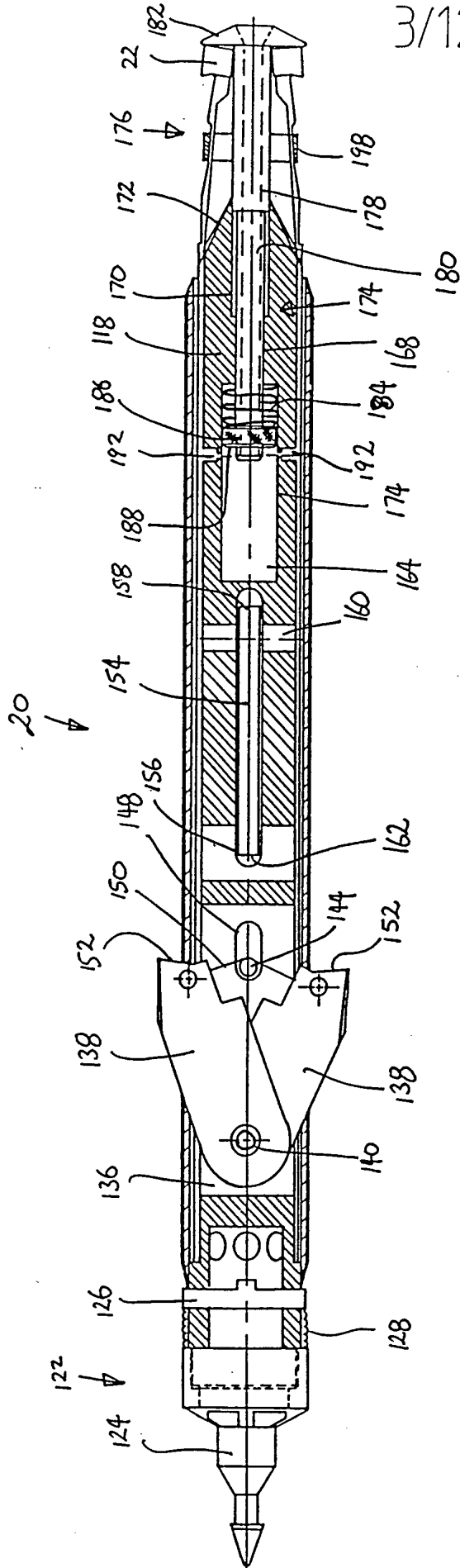

FIG 3

4/12

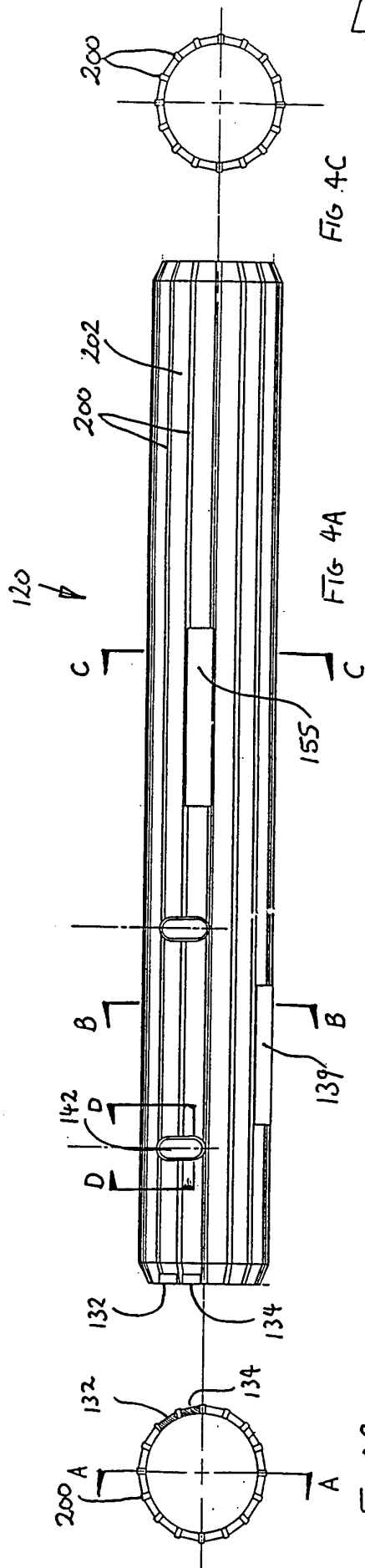

FIG 4C

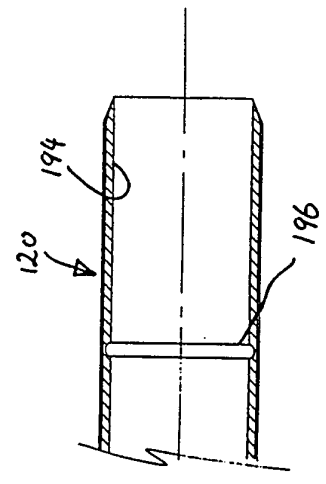

FIG 4F

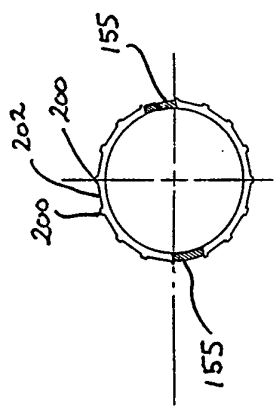

FIG 4E

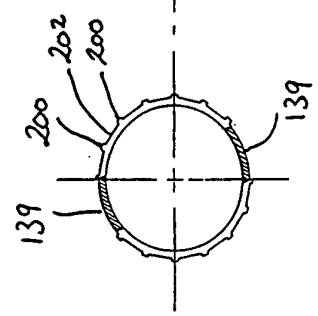

FIG 4D

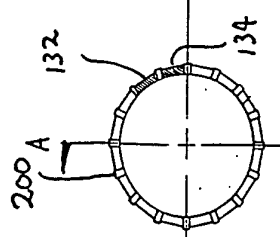

FIG 4B

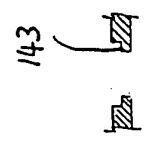

FIG 4G

5/12

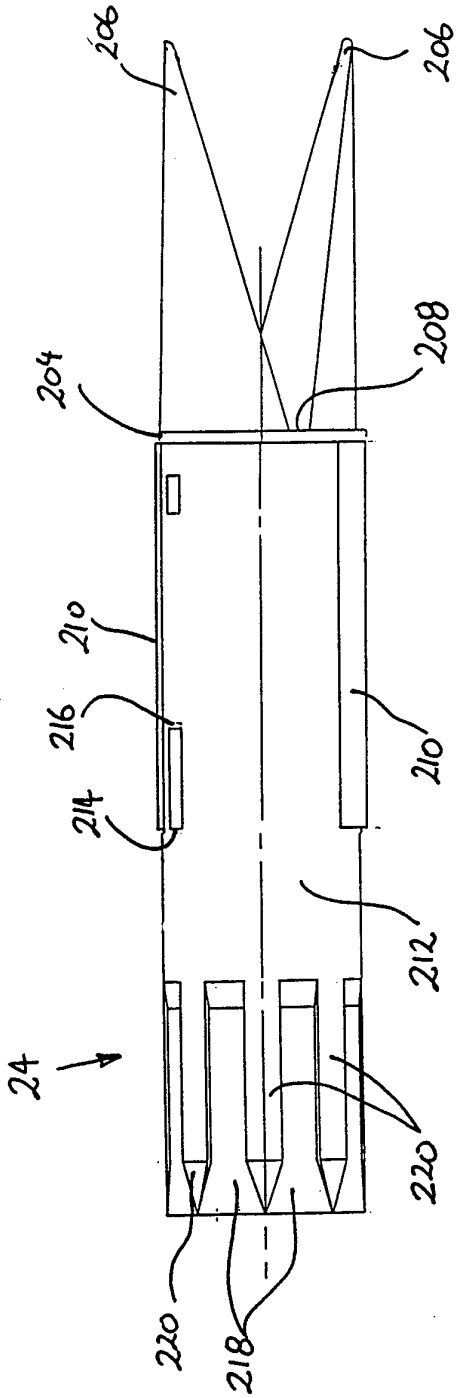

FIG 5A

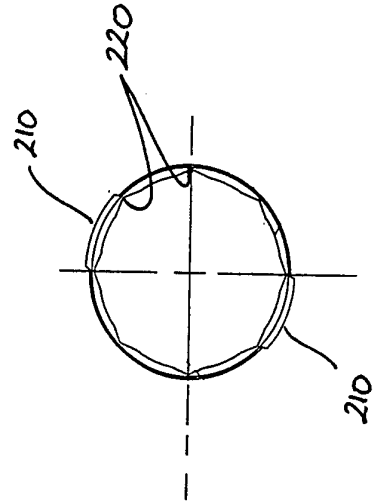

FIG 5C

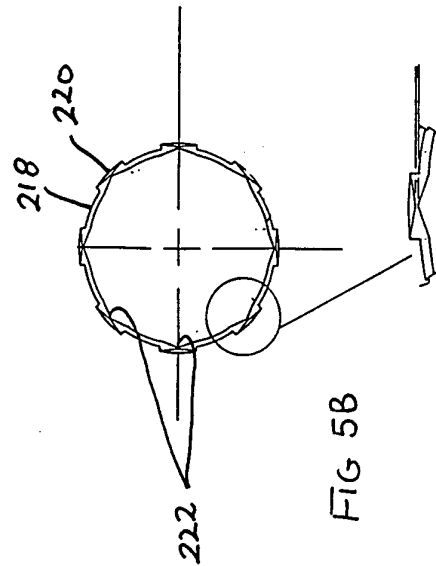

FIG 5B

6/12

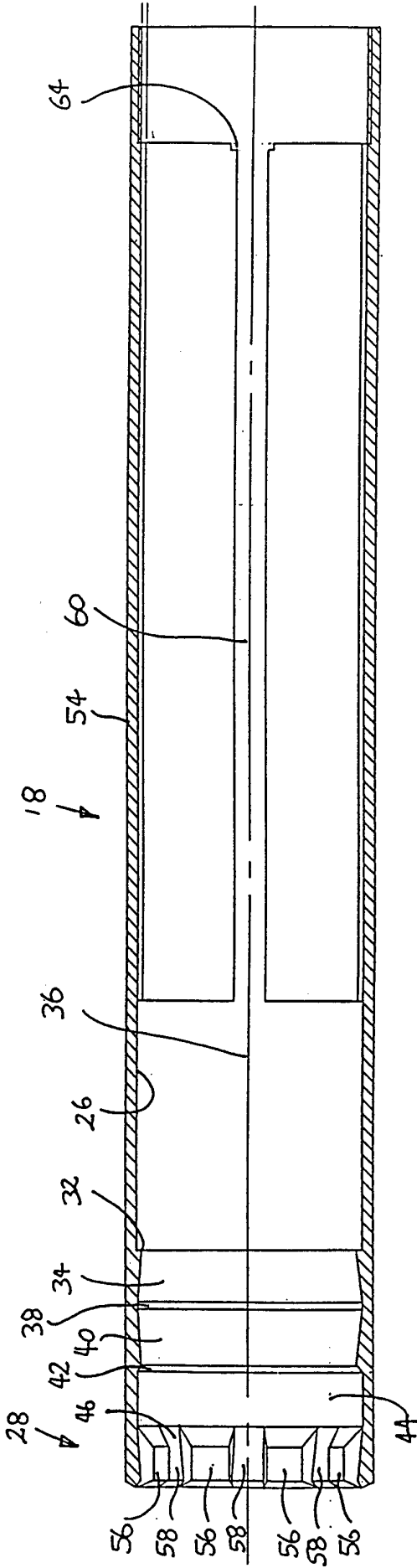

FIG 6A

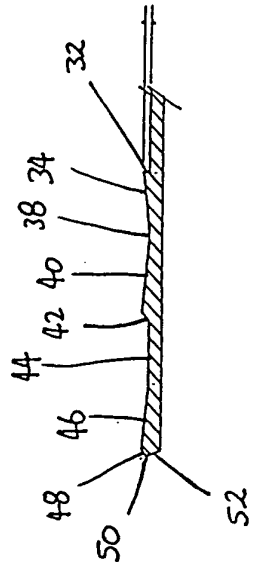

FIG 6D

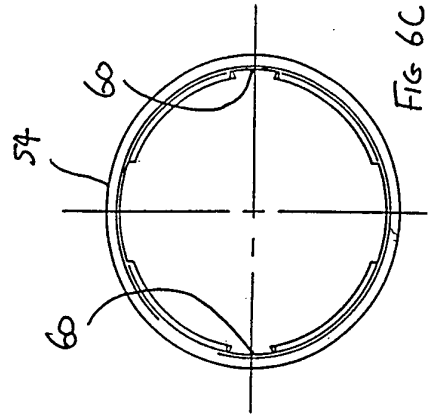

FIG 6C

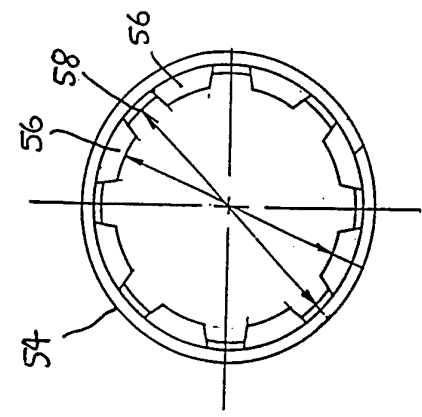
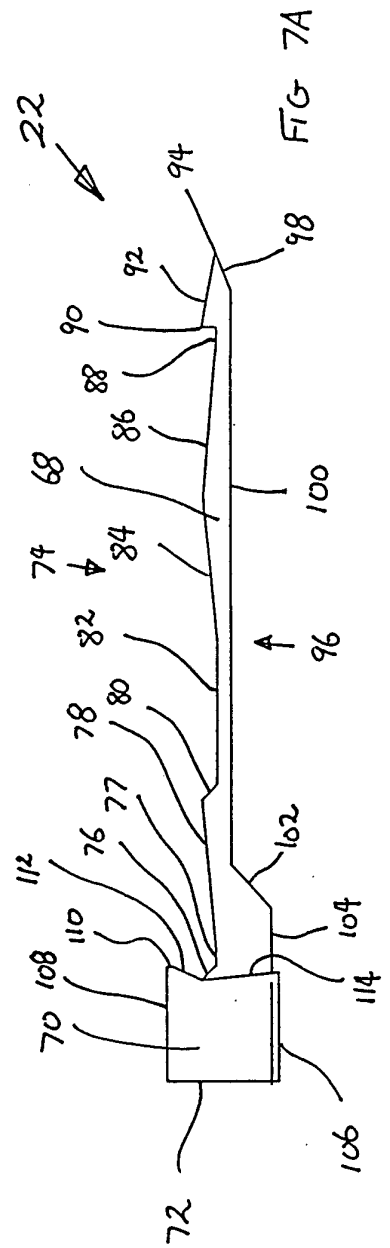
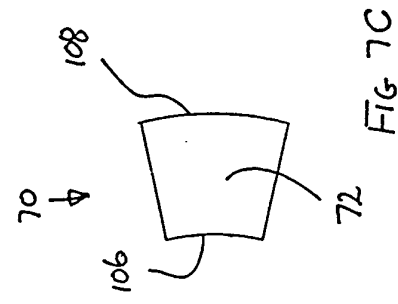
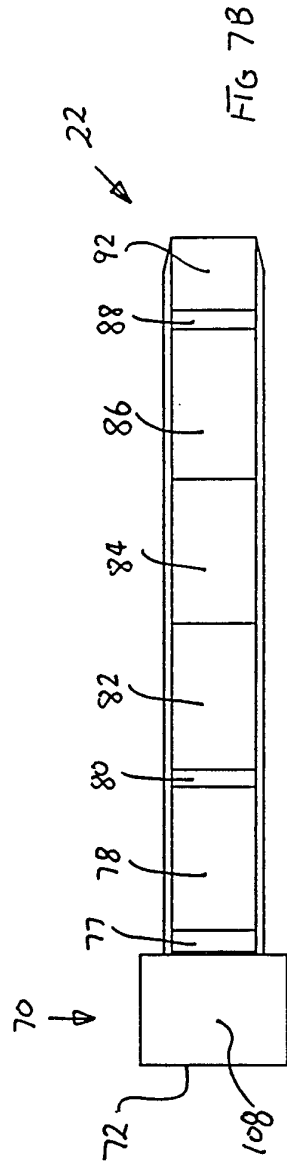
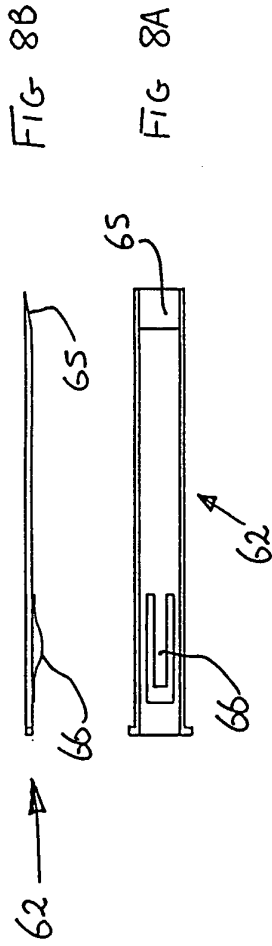

FIG 6B

7/12



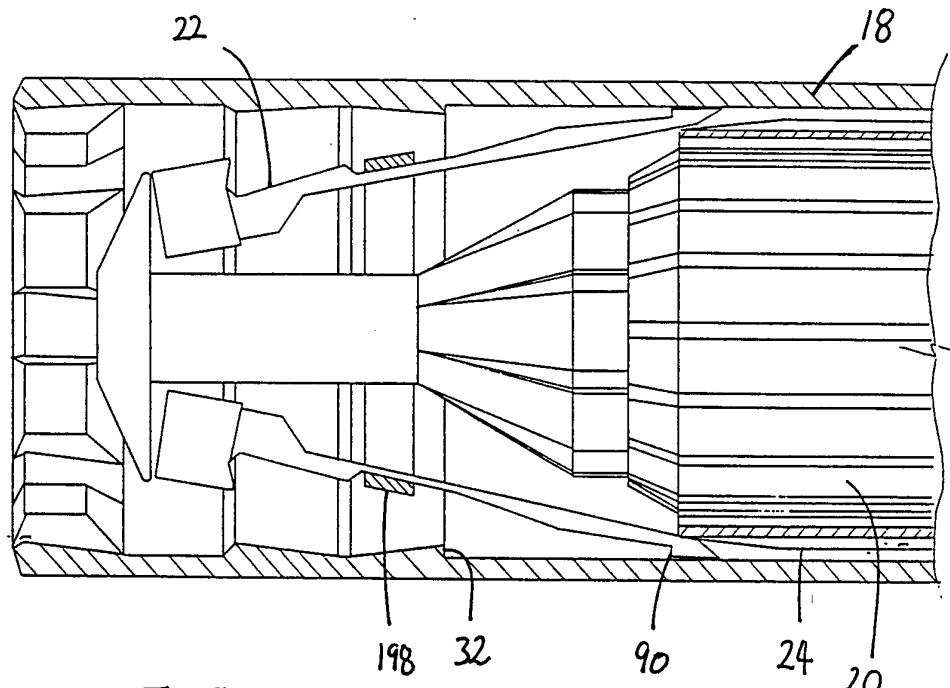

FIG 9

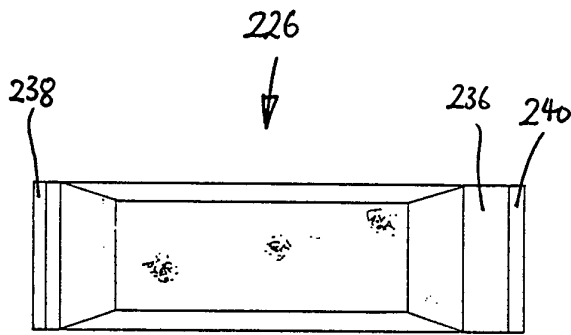

FIG 13

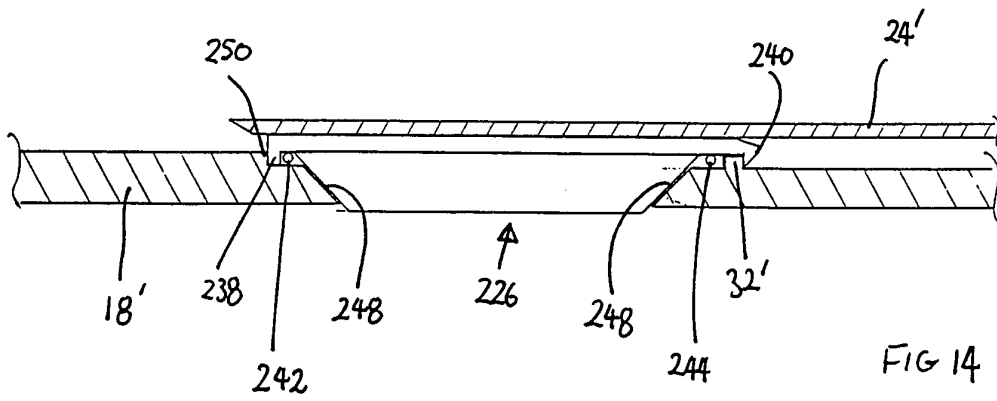

FIG 14

9/12

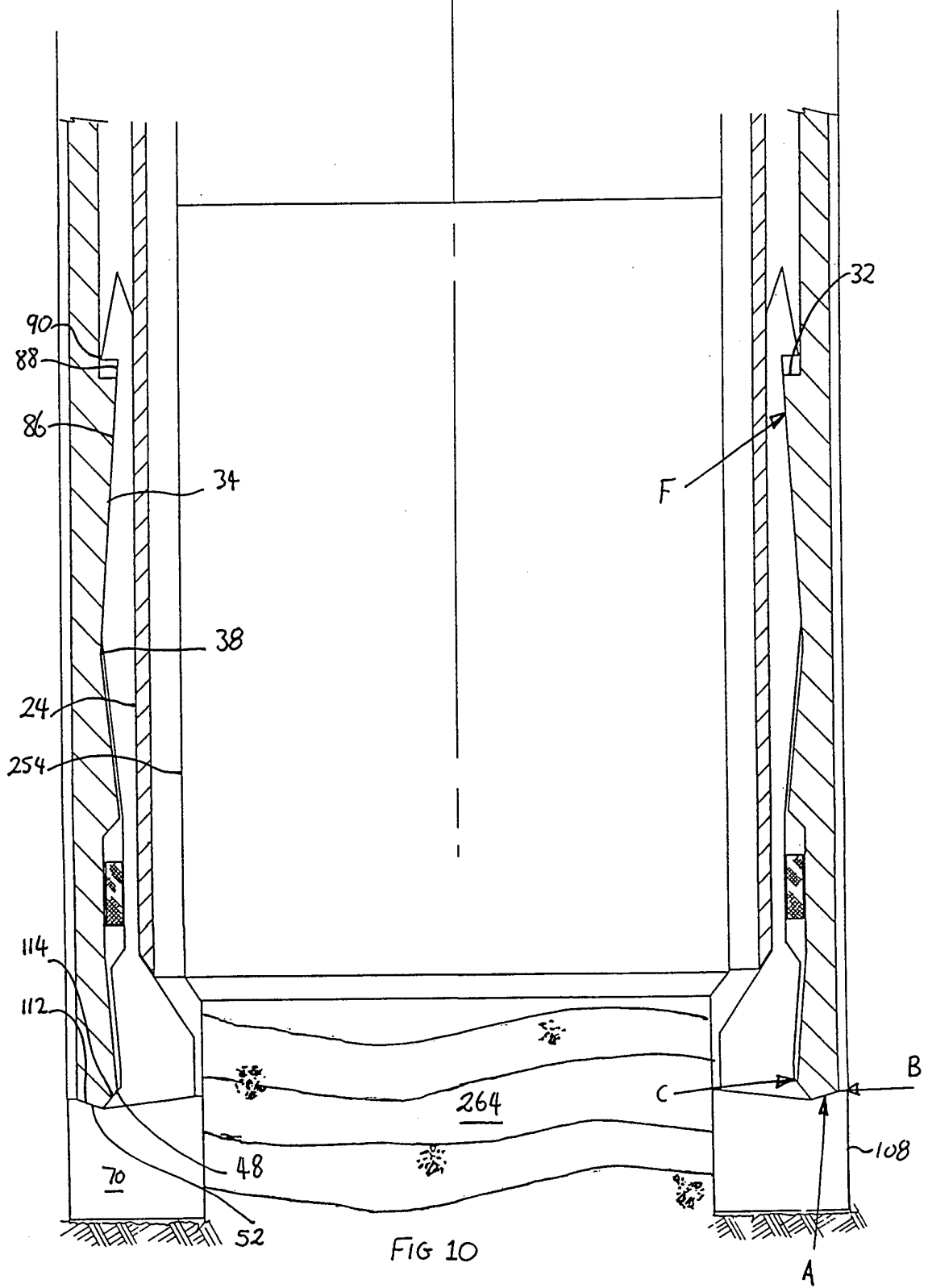

FIG 10

10/12

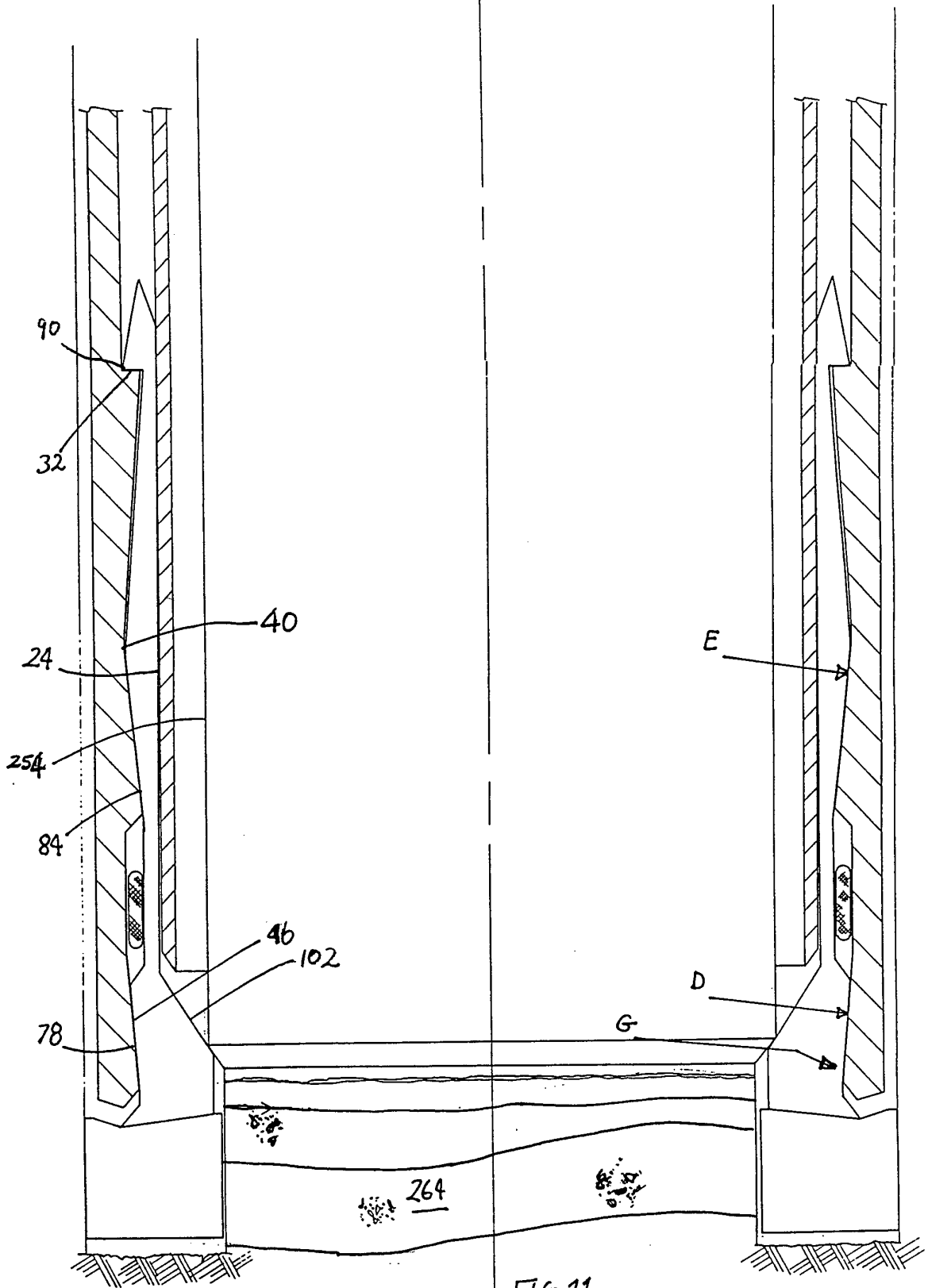

FIG 11



12/12

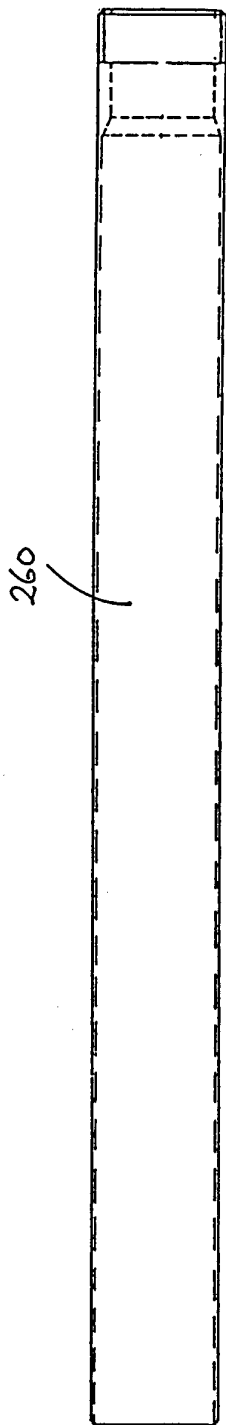

FIG 15

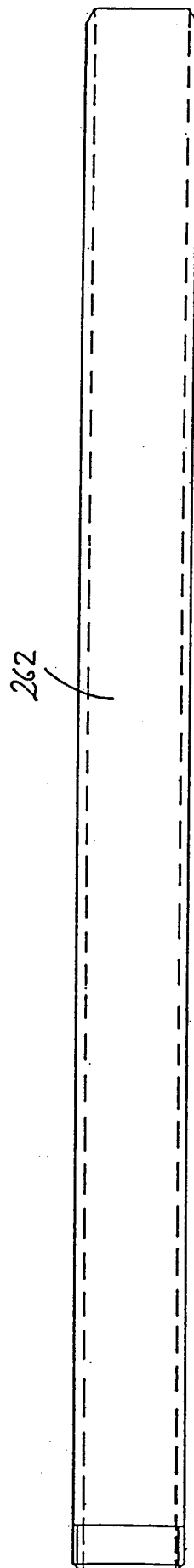



FIG 16

<b>A. CLASSIFICATION OF SUBJECT MATTER</b> Int. Cl. <sup>6</sup> E21B 23/03, 10/66  According to International Patent Classification (IPC) or to both national classification and IPC																						
<b>B. FIELDS SEARCHED</b>  Minimum documentation searched (classification system followed by classification symbols) Int. Cl. <sup>5</sup> : E21B 23/03, 23/00  Documentation searched other than minimum documentation to the extent that such documents are included in the fields searched AU : E21B 23/03, 23/00, 10/66  Electronic data base consulted during the international search (name of data base, and where practicable, search terms used)																						
<b>C. DOCUMENTS CONSIDERED TO BE RELEVANT</b>																						
Category*	Citation of document, with indication, where appropriate, of the relevant passages	Relevant to Claim No.																				
A	US,A, 4828023 (LEGGETT) 9 May 1989 (09.05.89)	1																				
A	US,A, 2640546 (BAKER) 2 June 1953 (02.06.53)	1																				
A	US,A, 2358466 (MILLER) 19 September 1944 (19.09.44)	1																				
A	GB,A, 788637 (BAKER OIL TOOLS) 2 January 1958 (02.01.58)	1																				
<input type="checkbox"/> Further documents are listed in the continuation of Box C. <input type="checkbox"/> See patent family annex.																						
* Special categories of cited documents : <table border="0"> <tr> <td>"A"</td> <td>document defining the general state of the art which is not considered to be of particular relevance</td> <td>"T"</td> <td>later document published after the international filing date or priority date and not in conflict with the application but cited to understand the principle or theory underlying the invention</td> </tr> <tr> <td>"E"</td> <td>earlier document but published on or after the international filing date</td> <td>"X"</td> <td>document of particular relevance; the claimed invention cannot be considered novel or cannot be considered to involve an inventive step when the document is taken alone</td> </tr> <tr> <td>"L"</td> <td>document which may throw doubts on priority claim(s) or which is cited to establish the publication date of another citation or other special reason (as specified)</td> <td>"Y"</td> <td>document of particular relevance; the claimed invention cannot be considered to involve an inventive step when the document is combined with one or more other such documents, such combination being obvious to a person skilled in the art</td> </tr> <tr> <td>"O"</td> <td>document referring to an oral disclosure, use, exhibition or other means</td> <td>"&amp;"</td> <td>document member of the same patent family</td> </tr> <tr> <td>"P"</td> <td>document published prior to the international filing date but later than the priority date claimed</td> <td></td> <td></td> </tr> </table>			"A"	document defining the general state of the art which is not considered to be of particular relevance	"T"	later document published after the international filing date or priority date and not in conflict with the application but cited to understand the principle or theory underlying the invention	"E"	earlier document but published on or after the international filing date	"X"	document of particular relevance; the claimed invention cannot be considered novel or cannot be considered to involve an inventive step when the document is taken alone	"L"	document which may throw doubts on priority claim(s) or which is cited to establish the publication date of another citation or other special reason (as specified)	"Y"	document of particular relevance; the claimed invention cannot be considered to involve an inventive step when the document is combined with one or more other such documents, such combination being obvious to a person skilled in the art	"O"	document referring to an oral disclosure, use, exhibition or other means	"&"	document member of the same patent family	"P"	document published prior to the international filing date but later than the priority date claimed		
"A"	document defining the general state of the art which is not considered to be of particular relevance	"T"	later document published after the international filing date or priority date and not in conflict with the application but cited to understand the principle or theory underlying the invention																			
"E"	earlier document but published on or after the international filing date	"X"	document of particular relevance; the claimed invention cannot be considered novel or cannot be considered to involve an inventive step when the document is taken alone																			
"L"	document which may throw doubts on priority claim(s) or which is cited to establish the publication date of another citation or other special reason (as specified)	"Y"	document of particular relevance; the claimed invention cannot be considered to involve an inventive step when the document is combined with one or more other such documents, such combination being obvious to a person skilled in the art																			
"O"	document referring to an oral disclosure, use, exhibition or other means	"&"	document member of the same patent family																			
"P"	document published prior to the international filing date but later than the priority date claimed																					
Date of the actual completion of the international search 23 August 1994 (23.08.94)		Date of mailing of the international search report 1 Sept 1994 (01.09.94)																				
Name and mailing address of the ISA/AU AUSTRALIAN INDUSTRIAL PROPERTY ORGANISATION PO BOX 200 WODEN ACT 2606 AUSTRALIA  Facsimile No. 06 2853929		Authorized officer  DAVID LEE   Telephone No. (06) 2832107																				