

A. PALMROS.
LINK FOR CHAINS.

(Application filed Apr. 27, 1901.)

(No Model.)

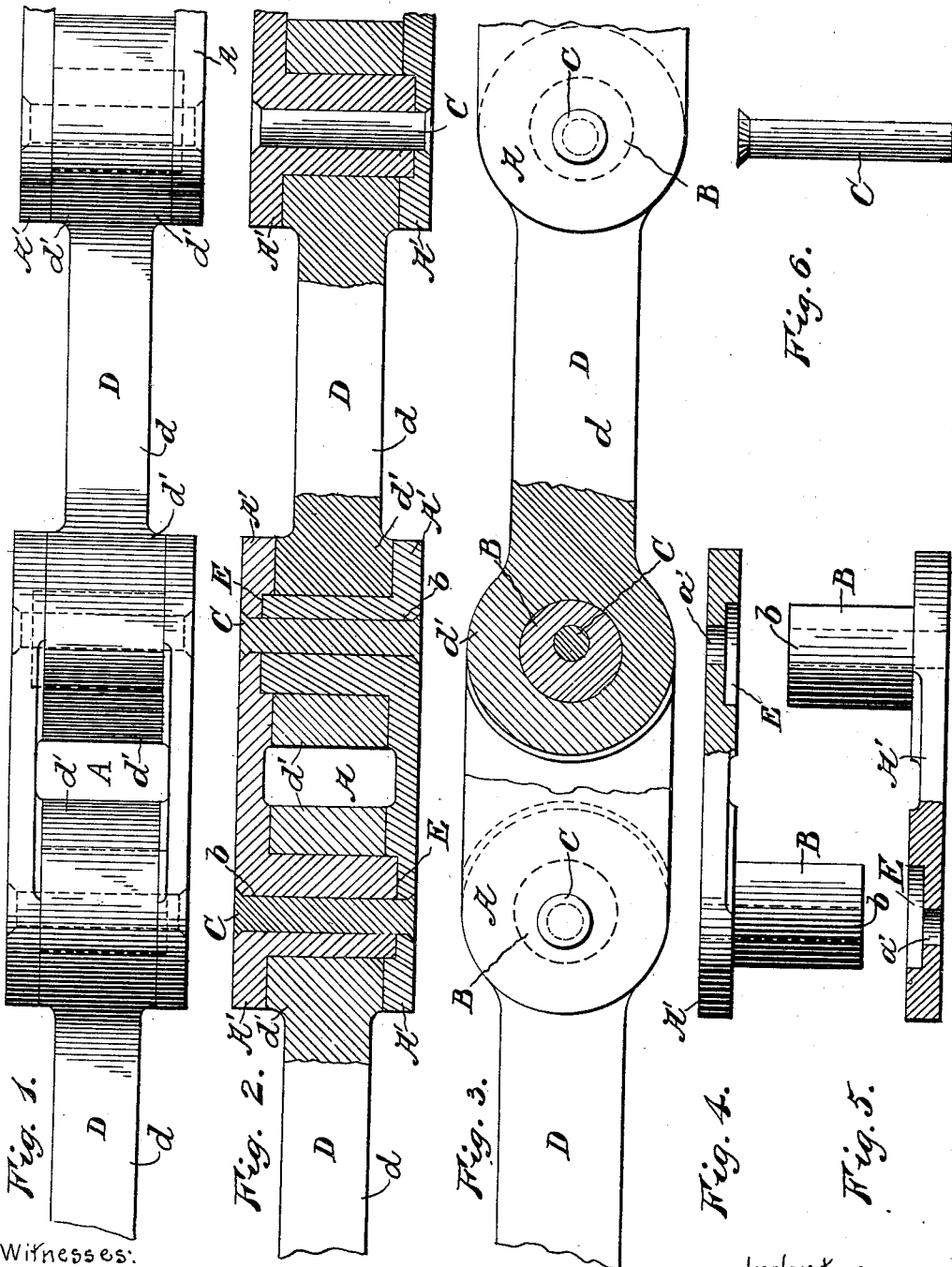

Witnesses:

A. K. Williams Jr.
N. Curtis Hammond

Inventor
Alexander Palmros,

By A. H. Bliss
Attorney.

UNITED STATES PATENT OFFICE.

ALEXANDER PALMROS, OF FAIRMONT, WEST VIRGINIA, ASSIGNOR TO THE WAGNER-PALMROS MANUFACTURING COMPANY, OF FAIRMONT, WEST VIRGINIA, A CORPORATION OF WEST VIRGINIA.

LINK FOR CHAINS.

SPECIFICATION forming part of Letters Patent No. 697,165, dated April 8, 1902.

Application filed April 27, 1901. Serial No. 57,697. (No model.)

To all whom it may concern:

Be it known that I, ALEXANDER PALMROS, a citizen of Finland, residing at Fairmont, in the county of Marion and State of West Virginia, have invented certain new and useful
5 Improvements in Links for Chains and other Purposes, of which the following is a specification, reference being had therein to the accompanying drawings.

10 Figure 1 is a plan view of a portion of a chain containing my improvements. Fig. 2 is a longitudinal section of the same. Fig. 3 is a view, partly in side elevation, partly in section. Fig. 4 is a view of one of the side bars
15 and its integral end bar. Fig. 5 is a similar view of the opposite side bar and its integral end bar. Fig. 6 shows the pin, which can be used as the means for fastening the side bars together.

20 In the drawings I have indicated a chain built up of links of two sorts alternating with each other, A indicating as a whole the links of one of these sorts, and D indicating the intermediate or alternating links. Each of the
25 links A is constructed with two independently-formed separable side bars A' A', each of these being cast or otherwise formed integrally with one of the end bars B. The side bars proper, A', are preferably flat, and each
30 near one end is perforated, as at *a'*, for the passage of the means which connect the two side bars together, such as screw-bolts, pins, or rivets C. Each side bar A' is upon its inner face formed with a recess E, the diameter and conformation of which correspond
35 to those of the free end of an end bar B. These end bars are somewhat longer than the normal width of the interior of the chain-link, so as to permit their free ends to be inserted
40 into and seated to a suitable depth in the recesses E, and as they fit snugly in said recesses there is provided an interlocking connection between each side bar and the end bar B which is integral with the opposing
45 side bar.

The intermediate links D, when made as shown, are each formed with a single shank-bar *d*, which at the ends is expanded to provide an enlarged bearing and connecting
50 head *d'*. The latter has a central aperture

of a diameter such that it can be fitted to one of the aforesaid end bars B. The movements of the articulation for the links are provided by means of these perforated heads *d'* and said end bars, and a large wearing-surface is
55 insured.

A number of important advantages are secured by forming the links A in the way described—that is, so that each side bar shall have one of the end bars integral therewith
60 and shall have a recess E to receive the end of the other end bar. In the first place it provides for building up the chain with only two patterns, the parts A' being duplicates and the links D being also similar to each other
65 throughout the series except where the links D are specially constructed for performing some function, such as carrying cutters, supporting buckets, or the like; secondly, the end bars B can be produced in such way as
70 to require no laborious or expensive machine-work in securing them in place to the side bars and the manipulating of them as separate articles in stock is avoided; third, the tensile strength of the chain is greatly increased, because of the fitting of the free ends
75 of the end bars in the cavities or recesses in the side bars opposite to them, respectively. An exceedingly powerful strain is necessary to cause a fracture of either the side bar A' at
80 points adjacent to the recess E or of the end bar itself at the free end. Not only is the strength increased at the place of junction in the recess E, but the liability to fracture at the opposite end, where it is cast integral with the
85 side bar, is reduced.

Any preferred or suitable means can be used for fastening together the two parts which constitute the links A. For most purposes, however, I find the riveted pin shown
90 to be sufficient. To allow of its use, the end bar B is perforated longitudinally on lines which register with the aforesaid aperture *d'* in the side bar A'. The aperture *b* referred to and also that at *a'* can be, as shown, eccentric to the axis of the parts B and relatively nearer the ends of the link. This provides for having a greater amount of metal on the inner side, where the greatest wear occurs.
100

My improved link may be used in any connection to which it is by its structure applicable or an element in a chain in which any suitable form of intermediate link D may be used. The form of link D herein shown is merely suggestive.

In using my improved link as an element in a machine I do not limit the invention to the precise dimensions shown, as they can be varied to meet the different purposes which are to be accomplished by the use of the chain. The links A may be made of such length as to permit the sprocket-teeth of the guiding or driving wheels to move into and out from the central space between the adjacent ends of the links D, or said sprocket-teeth can engage with ends of the links A.

What I claim is—

1. A link or connecting element for chains or other structures comprising two separable side bars and two end bars, each end bar being integral with one end of one side bar and interlocked detachably with the opposite side bar, and the interlocking ends of the side bars being each provided with a recess into which the free end of an end bar fits, and means for connecting said opposite side bars together.

2. A link or connecting element comprising separable side bars, end bars, each rigidly attached at one end to a side bar and of a length to be inserted partly into the opposite side bar, and thereby positively engage with it, and means separate from the end bars for securing the side bars to the free inserted ends of the end bars, substantially as set forth.

3. A link or connecting element formed of separable side bars and end bars, each end bar being rigidly attached at one end to one side bar and having interlocking detachable engagement with the opposite side bar, and means independent of the end bars for uniting the opposite side bars, substantially as set forth.

4. A link or connecting element comprising side bars, tubular end bars each integral with one end of one side bar and seated in a depression in the opposite side bar but not extend-

ing therethrough, and means for securing the parts together, passing through the side bars and the end bars.

5. A link comprising side bars perforated for the passage of connecting-pins, and having recesses E formed in their inner faces, tubular end bars each rigidly secured at one end to a side bar and of a length to extend to the opposite side bar and enter a recess E, whereby the free end of the end bar has an interlocking engagement with a side bar, and connecting-pins, for uniting the opposite side bars, substantially as set forth.

6. A link comprising recessed side bars and cylindrical end bars of uniform diameter from end to end, each end bar being rigidly secured to one of the side bars and of a length to extend to the opposite side bars and arranged to be seated in a recess therein, and means for connecting the opposite side bars, substantially as set forth.

7. A link element comprising a side bar and a hollow or tubular end bar integral with one end of the side bar, the side bar having at its opposite end a recess extending but part way through the side bar and arranged to receive the end bar of a corresponding element, substantially as set forth.

8. A link comprising duplicate elements, each formed of a side bar perforated at its opposite ends for the passage of connecting-pins and having its inner face recessed, as at E, near one end, and a tubular or hollow end bar integral with the side bar and projecting laterally from the side bar near the end opposite the said recess, the end bars being of a length to extend to the opposite side bars and enter the recesses E, and connecting-pins for uniting the side bars, substantially as set forth.

In testimony whereof I affix my signature in presence of two witnesses.

ALEXANDER PALMROS.

Witnesses:

J. C. EVANS,

S. G. CHADWICK, Jr.