

United States Patent Office.

HAMILTON E. TOWLE, OF NEW YORK, N. Y.

Letters Patent No. 108,409, dated October 18, 1870; antedated October 12, 1870.

IMPROVEMENT IN SHUTTLES.

The Schedule referred to in these Letters Patent and making part of the same

To all whom it may concern:

Be it known that I, HAMILTON E. TOWLE, of New York, in the county and State of New York, have invented a certain new and useful Improvement in Shuttles, of which the following is a specification.

The said invention relates to the adjustment of the tension of the weft drawn from the shuttle, and is applicable to the regulation of the tension in sewing-machines, and to other similar purposes in which it may be desirable to regulate the degree of tension of a spring, and the method in which the tension is applied and varied within the range of its elasticity.

The variations of the tension on the weft require that the filling shall be strong enough to withstand the greatest ordinary strain to which it may be subjected, and the application of means by which the tension may be made more uniform permits the employment, therefore, of the finest thread and the highest rate of speed in the loom.

When the delivery from the bobbin, whether full or nearly empty, continues the same, with a uniform tension, the fabric will have a corresponding uniformity in texture, and present a straight and regular selvage.

The invention consists in the application of a spring and a lever that bears upon the filling in the spool, or bobbin, or quill of the shuttle, the total amount of the force exerted by the spring being adjusted by means of a key, and the manner of the application of the force so adjusted being regulated by the position of the fulcrum of the lever, so that, when the spool is nearly empty, and the spring is at its least extension, the leverage is most direct upon it, or at right angles; and, when the spool is quite full, and the strain upon the spring the greatest, its force is applied more angularly to the lever.

Description of the Drawing.

Figures 1 and 2 represent, respectively, a plan and elevation of a shuttle, with the spool or quill placed with its axis at right angles to the line of motion of the shuttle.

This position of the spool is preferred, because the angle of the delivery of the thread remains more nearly constant than is the case when the axis of the spool conforms with the longitudinal axis of the shuttle.

The shuttle *a* incases the spool *b*, which turns upon the axis *c*, and is pressed upon by the lever *d* bearing upon the filling.

The opposite end of the lever, beyond the fulcrum *e*, is attached to the spring *f*, that is stretched by the

cord *i* passing over the pulley *g*, and winding around the barrel *h*, which may be turned by the key *k*.

By tightening up the cord with the key, the elongation and elastic force of the spring, and its action upon the lever, may be regulated at pleasure.

The friction of the pin or barrel in the material of the shuttle is sufficient to retain it for practical purposes.

In the position of the lever shown in the drawing, the end at the spool is upon the least amount of filling, and the tension of the spring is at its minimum; but the end of the lever to which the force of the spring is applied is at right angles to the direction of the force, and, therefore, receives the lessened force most advantageously.

In a similar manner, when the spool is full, and the spring most extended, and exercising its greatest force, the force of the spring is applied at an angle less than ninety degrees, and, therefore, at a disadvantage.

At the two extreme points, and between them, the varying tension of the spring is accompanied by a corresponding variation of the angle at which the tension or force is applied, so that the retaining power upon the spool, resulting from the application of the variable spring through the variable lever, remains unchanged.

The hub of the lever should be made of sufficiently large diameter to be bored with several holes for the reception of the pin upon which it turns, to enable the position of the fulcrum, and the consequent angularity of the leverage, to be changed or adjusted as may be required.

The same end may be attained by any other means of shifting the center, and the position of the center may, likewise, be adapted to the end of the lever bearing upon the spool, for the purpose of accomplishing the same result, by making its action more or less angular upon the spool, as the spool is more or less full.

I claim as my invention—

The combination, with the shuttle, of the spring, the lever, and the barrel for regulating the strength or tension of the spring, when constructed and combined substantially as described, so that the force of the spring and lever may be varied, to produce a uniform tension of the shuttle-thread, notwithstanding the decreasing size of the bobbin.

New York, June 24, 1869.

HAMILTON E. TOWLE.

Witnesses:

T. W. FARNSWORTH,
FREDK. L. MEEKS.

ALVAH TRAYER'S IMPROVEMENTS IN STOVES

108410

PATENTED OCT 18 1870

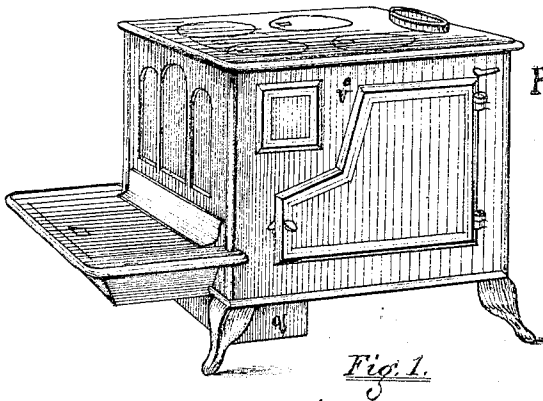

Fig. 1.

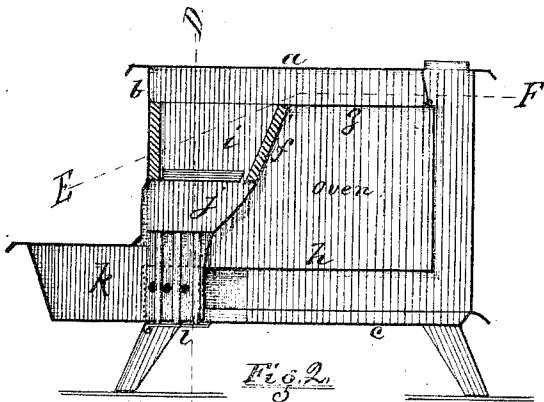

Fig. 2.

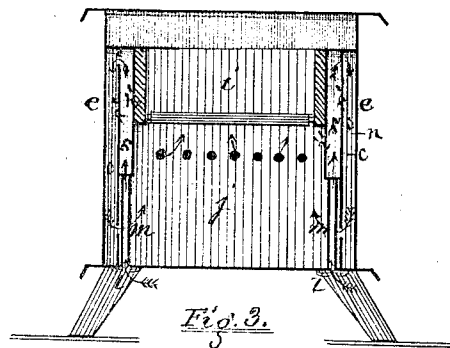

Fig. 3.

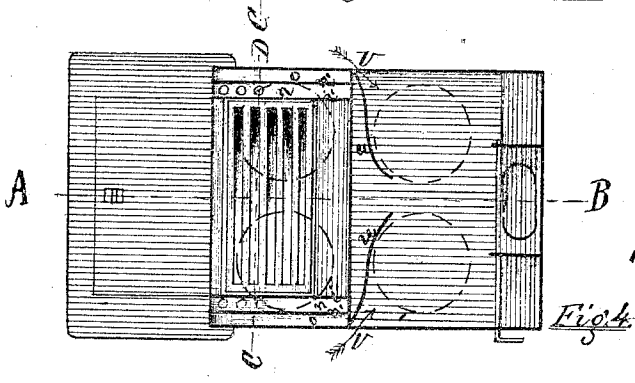

Fig. 4.

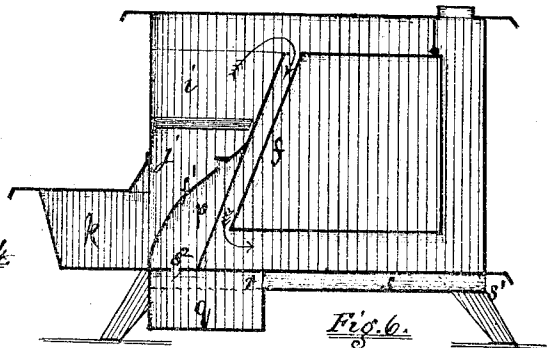

Fig. 5.

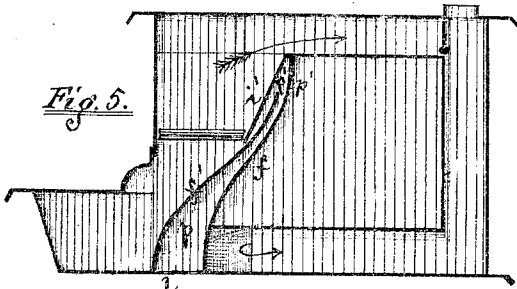

Fig. 6.

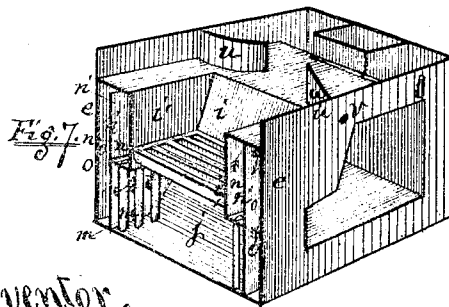

Fig. 7.

Witnesses.

Richard H. Reille

A. J. Reille

Inventor.

Alvah Trayer



UNITED STATES PATENT OFFICE.

ALVAH TRAYER, OF TROY, NEW YORK.

IMPROVEMENT IN COOKING-STOVES.

Specification forming part of Letters Patent No. 108,410, dated October 18, 1870.

I, ALVAH TRAYER, of the city of Troy, county of Rensselaer and State of New York, have invented certain Improvements in Cooking-Stoves, of which the following is a specification:

The nature of my invention is as follows: I construct and arrange chambers at the ends of the fire-pot of a cooking-stove, double on each end of the fire-pot, one chamber next adjoining the fire-pot, and another chamber between the first and the outer walls or jambs of the stove, the same arrangement on each side or end of the fire-pot. The said chambers are divided from each other by a suitable division-plate, having apertures at its upper end, or so constructed that a communication may be made between the two chambers. The chamber next adjoining the fire-pot extends no further downward than about the lower line of the grate. The outer chamber may reach downward to the bottom of the stove, or to any intermediate point. This arrangement of chambers may be continued all around the fire-pot, if desirable; as, for instance, in a cylinder or heating stove. It also consists in the employment and construction of pipes, tubes, or the equivalent thereof, reaching downward from the bottom of the chamber next adjoining the fire-pot to the bottom-plate of the stove, and passing through the same, so that dampered orifices or entrances may be had at their lower ends; and they are open at their upper ends into the chamber above mentioned. The outer chamber next adjoining the outer walls of the stove has apertures at any suitable points below the bottom of the other chamber, so that air may pass out therefrom and into the ash-pit or chamber below the grate of a stove.

The object of this arrangement and construction of chambers and tubes is to provide a means of highly heating draft-air for the fire, whereby combustion is rendered more perfect, and the heating qualities of the burning fuel much increased. The air rushes in through the pipes or tubes, upward and into the chamber next adjoining the fire-pot, therein becoming highly heated, and from thence passes into the outer chamber, and downward thereinto and, through the apertures at the lower part, enter the chamber or space below the grate of the stove, and so to the fire. Ex-

cept while kindling or starting the fire, the supply of air is furnished through these chambers, and in no other way.

The outer chamber may be constructed so as to be entirely open at the bottom, and the air, in that case, will be admitted in a broad sheet to the chamber or space below the grate, thus making a steady and uniform draft; and again, a chamber may be constructed below the bottom of the stove, and adjoining thereto, as an auxiliary chamber, into which atmospheric air is admitted previous to its passage or entrance into the tubes before mentioned, the chamber having suitable inlet apertures for the purpose; or, a series of tubes, or the equivalent thereof, may be constructed along and under the bottom of the stove, and in close contact therewith, and reaching from the last-mentioned auxiliary chamber backward to the back or rear part of the stove, and opening into the said chamber, and having suitable openings at the rear or outer ends for inlet of air thereto; and, in this case, the air first enters such tubes, or the equivalent thereof, and, passing through the same, enters the auxiliary chamber, and from thence, through apertures, is admitted to the chamber below the grate, or, through orifices at ends of the tubes, inside the stove, rises upward to the first-mentioned heating-chambers, at the ends or around the fire-pot.

The construction of said tubes and chamber below the bottom of the stove utilizes the heat radiated from the bottom plate and bottom flues of the stove, and also prevents the cooling off of the said flues, by keeping them from direct contact with cold or outer air. The air, after entering the auxiliary chamber below the bottom of the stove, may be conducted into a chamber reaching upward from the bottom of the stove, and inside the same, and extending across the whole width of the stove, and in height reaching to the top of the fire-pot, and having apertures, dampered or not, as required, at any suitable height or points, so that the air may be supplied to the fire as draft, this chamber becoming a draft-supply chamber; and again, this just-mentioned chamber may be used without the auxiliary chamber below the bottom plate of the stove. In this case, the air enters this draft-supply chamber through apertures in and through