



INTERNATIONAL APPLICATION PUBLISHED UNDER THE PATENT COOPERATION TREATY (PCT)

<p>(51) International Patent Classification <sup>6</sup> : <b>A61F 13/56, 13/58</b></p>	<p><b>A1</b></p>	<p>(11) International Publication Number: <b>WO 99/17697</b> (43) International Publication Date: 15 April 1999 (15.04.99)</p>
<p>(21) International Application Number: PCT/US98/03501 (22) International Filing Date: 23 February 1998 (23.02.98) (30) Priority Data: 08/944,169 6 October 1997 (06.10.97) US (71) Applicant: MINNESOTA MINING AND MANUFACTURING COMPANY [US/US]; 3M Center, P.O. Box 33427, Saint Paul, MN 55133-3427 (US). (72) Inventors: MELBYE, William, L.; P.O. Box 33427, Saint Paul, MN 55133-3427 (US). SETH, Jayshree; P.O. Box 33427, Saint Paul, MN 55133-3427 (US). (74) Agents: BOND, William, J. et al.; Minnesota Mining and Manufacturing Company, Office of Intellectual Property Counsel, P.O. Box 33427, Saint Paul, MN 55133-3427 (US).</p>	<p>(81) Designated States: AL, AM, AT, AU, AZ, BA, BB, BG, BR, BY, CA, CH, CN, CU, CZ, DE, DK, EE, ES, FI, GB, GE, GH, GM, GW, HU, ID, IL, IS, JP, KE, KG, KP, KR, KZ, LC, LK, LR, LS, LT, LU, LV, MD, MG, MK, MN, MW, MX, NO, NZ, PL, PT, RO, RU, SD, SE, SG, SI, SK, SL, TJ, TM, TR, TT, UA, UG, UZ, VN, YU, ZW, ARIPO patent (GH, GM, KE, LS, MW, SD, SZ, UG, ZW), Eurasian patent (AM, AZ, BY, KG, KZ, MD, RU, TJ, TM), European patent (AT, BE, CH, DE, DK, ES, FI, FR, GB, GR, IE, IT, LU, MC, NL, PT, SE), OAPI patent (BF, BJ, CF, CG, CI, CM, GA, GN, ML, MR, NE, SN, TD, TG).</p> <p><b>Published</b> <i>With international search report.</i></p>	

(54) Title: CLOSURE SYSTEM FOR DISPOSABLE ABSORBENT ARTICLE

(57) Abstract

A closure system and method of making a closure system for a disposable article. A substantially continuous closure system web is provided. One face of the web is provided with first fastening region at terminal end portion(s) (32) of the web. A second fastening region (33), engagable with the first fastening region, is provided on a second face of the web in a region adjacent the terminal end portion(s). The closure system tab elements (14) are cut from the web (1) and attached to a second web, used in producing the disposable article, at longitudinally spaced locations. This second web is then cut at transverse cut lines separating the closure system tab element into two functional elements. A first functional element has a fastening tab portion (99) and the second functional element has an attachment portion (93). The attachment portion of one closure system tab element (14) interacts with a fastening tab portion of an adjacent closure system tab element to form a functional closure system on a disposable article (91) made using the second web.

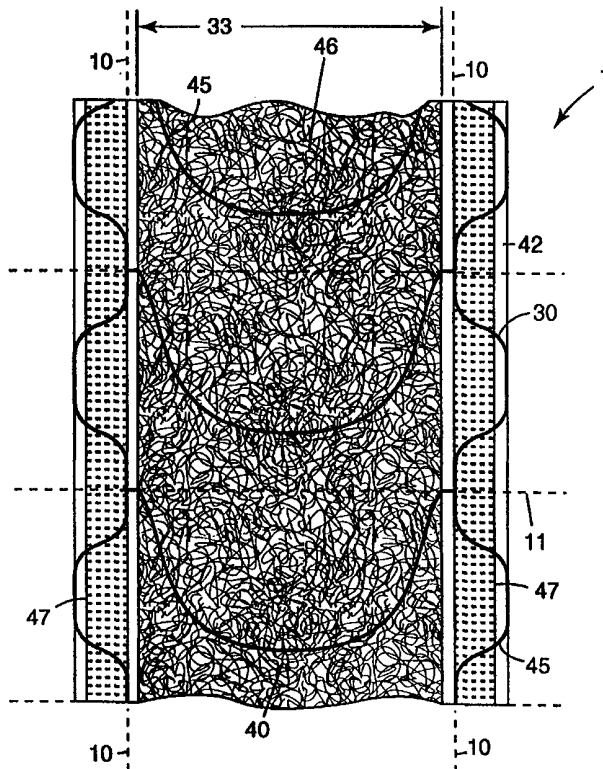

**FOR THE PURPOSES OF INFORMATION ONLY**

Codes used to identify States party to the PCT on the front pages of pamphlets publishing international applications under the PCT.

AL	Albania	ES	Spain	LS	Lesotho	SI	Slovenia
AM	Armenia	FI	Finland	LT	Lithuania	SK	Slovakia
AT	Austria	FR	France	LU	Luxembourg	SN	Senegal
AU	Australia	GA	Gabon	LV	Latvia	SZ	Swaziland
AZ	Azerbaijan	GB	United Kingdom	MC	Monaco	TD	Chad
BA	Bosnia and Herzegovina	GE	Georgia	MD	Republic of Moldova	TG	Togo
BB	Barbados	GH	Ghana	MG	Madagascar	TJ	Tajikistan
BE	Belgium	GN	Guinea	MK	The former Yugoslav Republic of Macedonia	TM	Turkmenistan
BF	Burkina Faso	GR	Greece			TR	Turkey
BG	Bulgaria	HU	Hungary	ML	Mali	TT	Trinidad and Tobago
BJ	Benin	IE	Ireland	MN	Mongolia	UA	Ukraine
BR	Brazil	IL	Israel	MR	Mauritania	UG	Uganda
BY	Belarus	IS	Iceland	MW	Malawi	US	United States of America
CA	Canada	IT	Italy	MX	Mexico	UZ	Uzbekistan
CF	Central African Republic	JP	Japan	NE	Niger	VN	Viet Nam
CG	Congo	KE	Kenya	NL	Netherlands	YU	Yugoslavia
CH	Switzerland	KG	Kyrgyzstan	NO	Norway	ZW	Zimbabwe
CI	Côte d'Ivoire	KP	Democratic People's Republic of Korea	NZ	New Zealand		
CM	Cameroon			PL	Poland		
CN	China	KR	Republic of Korea	PT	Portugal		
CU	Cuba	KZ	Kazakstan	RO	Romania		
CZ	Czech Republic	LC	Saint Lucia	RU	Russian Federation		
DE	Germany	LI	Liechtenstein	SD	Sudan		
DK	Denmark	LK	Sri Lanka	SE	Sweden		
EE	Estonia	LR	Liberia	SG	Singapore		

## CLOSURE SYSTEM FOR DISPOSABLE ABSORBENT ARTICLE

### Background and Field of the Invention

5           The present invention relates to a closure system for a disposable absorbent article, particularly multifunctional closure systems attachable to the waistband portions of the disposable absorbent article.

          In the field of disposable absorbent articles, typically disposable diapers and adult incontinent articles, closure systems are provided which generally are formed using pressure sensitive adhesive fastening tabs or mechanical fastening tabs. These tabs are generally attached to the disposable absorbent article at corner portions at at least one end of the article, e.g., a diaper. The typical fastening tabs have one end which is permanently bonded to the absorbent article and a second free end which is available for the user to removably attach to the opposing end of the article to effect closure. The opposing end of the absorbent article typically is provided with a mating attachment surface. In the case of pressure sensitive adhesive fastening tabs, the mating attachment surface typically is a reinforcement film or other material which is applied to the inside or outside face of the outer liquid impermeable layer of the disposable absorbent article. In the case of a mechanical fastening tab, the mating attachment surface is a loop fastening material which must be placed on the outside face of the liquid impermeable outer cover layer of the disposable absorbent article. In either case, the mating attachment surface is typically provided by applying a separate discrete element to the absorbent article. This could be a pressure sensitive adhesive element or a non-adhesive coated element bonded by other means such as hot melt adhesive or thermal welding. In certain extreme cases, the entire outer face of the disposable absorbent article can be provided with a suitable mating attachment surface for the fastening tab second free end, however this can be excessively costly. The fastening tab itself is also applied as a separate and discrete element to the corner of the disposable absorbent article, generally at the back end region. Generally, this permanent attachment of the fastening tab is made by a pressure sensitive adhesive applied at one end of the fastening tab with the other second end of the fastening tab provided with a suitable

pressure sensitive adhesive or mechanical fastening element for releasable attachment and closure of the absorbent article. The fastening tab can be applied as a separate piece cut from a roll which can be laminated with other suitable materials, such as a release tape, during the manufacture of the diaper.

5 Alternatively, the fastening tab can be provided with other suitable components in a pre-laminate form which also is cut from a continuous roll. These closure systems are highly effective but can be complicated, particularly when they are laminated on the diaper line and/or additional functionality is incorporated into the fastening tab, such as elasticity.

10 It has also been proposed in the patent literature that suitable belt means could be provided with attachment elements at the opposing ends of the belt to provide a closure system for use with a disposable absorbent article. Belts can address some of the issues regarding separate tab fasteners as some only require the use of a single laminate or the like which can be securely or releasably attached to a  
15 diaper absorbent pad or the like. However the use of two interconnecting belts have also been proposed. In U.S. Pat. Nos. 3,847,702 and 3,561,446, an inextensible belt material is provided both to the front and back ends of a disposable diaper. Each belt extends across the full width of the diaper and both belts are provided at the terminal ends with a pressure sensitive adhesive region which adhesive is covered  
20 until use with a release tape. When the diaper is closed, one belt is attached to some portion of the second belt at the opposite end of the diaper, and the adhesive on the terminal ends of the second belt is generally attached to the diaper on the diaper face opposite that provided with the first belt. These belts prevent inelastic deformation of the waistband region of the diaper during use. However, this two-  
25 belt system would be similar in manufacturing complexity to the use of tab fasteners.

French Pat. Nos. 2, 586,558, 2,725,879, and PCT Publ. No. 94/26224 teach the use of only one inextensible belt which single belt can be attached to the front or rear ends of the diaper, either permanently or by refastenable mechanical fastening  
30 elements. When the diaper is refastenably attached to the belt, the belt can be reused repeatedly. In these patent documents, the belt generally wraps around the

wearer and secures to itself with the diaper being releasably attached to the belt at least at one end of the diaper, and either releasably or permanently attached to the belt at the opposing end of the diaper. A similar approach is proposed in U.S. Pat. No. 4,964,860, and PCT Appln. No. 91/08725 where a reusable belt with  
5 mechanical fastening elements is used with a disposable diaper provided with mating mechanical fastening elements. These belts can be relatively easy to incorporate onto a diaper but lack the ease of use of a fastener tab closure system for the end user.

In EP Appln. No. 528282, a permanent integral waistband is provided on a  
10 diaper which waistband could be stretchable. The waistband is on one end of the diaper and wraps around the wearer's waist and attaches to itself forming a belt. Both the waistband and the front portion of the diaper are provided with suitable interengagable attachment elements 44 and 50 which could be any variety of attachment means including pressure sensitive adhesives, cohesive adhesives, and  
15 mechanical fasteners. The front portion of the diaper would attach to the waistband portion. This patent attempts to combine some of the benefits of a single belted system with those of a tab fastening closure system.

In U.S. Pat. No. 5,593,401, a bridging type element is provided at one end region of a diaper as a separate element to which may be attached two conventional  
20 fastening tabs at either end. The bridge strip has a secured side and an unattached side and is generally described as being elasticized. This bridge strip would require a separate attachment step and associated apparatus in order to be integrated into the disclosed conventional diaper constructions. This is similar to the above two belt systems but is more complicated in terms of its construction and manufacture.

Elasticized waist elements which may have attached fastening tabs that then  
25 releasably attach to a front panel portion of a diaper are disclosed in U.S. Pat. No. 4,998,929, and PCT Publ. Nos. WO 96/32083, and WO 95/22951. An elastic type belt element which wraps around the entire waist of the wearer and which is provided with inter-engaging mechanical fastening elements at its terminal ends is  
30 disclosed in U.S. Pat. No. 5,607,416. In all the above patent documents, there is a separate and distinct elastic element with the terminal edges generally including an

attachment element such as a pressure sensitive adhesive or a mechanical fastening element which attaches to the elastic belt as per U.S. Pat. No. 5,607,416 or to a suitable attachment mechanism on the other end portion of the diaper or like disposable absorbent article.

5           The use of two or one belt closure systems that wrap around one end of a diaper or the entire waist of the wearer, respectively, are desirable from a number of perspectives. The belt can be used with the closure system in a manner that provides other functionality such as elasticity or inextensibility that is actively integrated with the closure system. However, the means proposed for providing  
10 these belt and closure elements generally requires a number of separate attachment steps on the manufacturer's line.

          The invention is directed at addressing the manufacturing complexities of multicomponent closure systems by enabling the provision of an effective closure system by a single attachment step which can also provide additional desired  
15 functionality such as inextensible belt elements, extensible belts or bands, elasticity, and the like. The invention is also directed at a method of providing a diaper closure system and optionally a belt system on a diaper line by the use of a single closure system laminate.

#### 20 Brief Description of the Invention

          The invention comprises a closure system and a method of forming a closure system for a disposable absorbent article. The method comprises the steps of providing at least one substantially continuous web capable of forming a portion of a disposable absorbent article. The web has a first width dimension defining two  
25 side edges and an indefinite length dimension. A closure system web is also provided comprising at least one backing having a first face and a second face. The closure system web has a second width dimension generally greater than the first width dimension and an indefinite length. The first face of the closure system web is provided with at least one first fastening region at at least one terminal end  
30 portion of the closure system web. At least one second fastening region is provided on the second face of the closure system web in at least the second portion

adjacent the terminal end portion provided with the first fastening region. Closure system tab elements are cut from the closure system web, which tab elements have a definite length dimension. The closure system tab elements have at least one fastening tab portion, comprising the at least one first fastening region on the terminal end portion, and an attachment portion comprising the second portion having the second fastening region.

The closure system tab elements are then attached to the at least one substantially continuous web at regular spaced intervals along the indefinite length dimension in a continuous manner. The at least one continuous web is then cut along cut lines transverse to the indefinite length dimension to form discrete disposable absorbent articles. The transverse cut lines are such that they bisect the closure system tab elements along the tab element definite length dimension, so that the fastening tab portion is on a first side of the transverse cut line and the attachment portion is on a second opposing side of the cut line. This provides fastening tab portions on a first end of one absorbent article and an attachment portion on a second end of an adjacent absorbent article.

A closure system of the invention is used on a disposable absorbent article having a first width dimension defining two side edges and two end edges. The closure system comprises at least one fastening tab having a backing. A first face of the fastening tab backing is provided with at least one first fastening region at at least a first end. At least one second fastening region is provided on a first face of an attachment portion having a backing. The attachment portion has a top edge and a bottom edge. Preferably at least a discrete portion of the attachment portion top edge is laterally coextensive with a portion of a first end edge of the disposable absorbent article. A corresponding and coextensive discrete portion of a bottom edge of the at least one fastening tab is also preferably laterally coextensive with a second end edge of the disposable absorbent article. At least a portion of the attachment portion top edge is laterally coextensive with the bottom edge of the at least one fastening tab which both preferably form a portion of, or are adjacent to, end edges of the disposable absorbent article. The respective backings of the at least one fastening tab and the attachment portion are identical, at least at an area

adjacent the two discrete coextensive edge portions of the at least one fastening tab and the attachment portion.

#### Brief Description of the Drawings

5            Fig. 1 is a side cross sectional view of a first embodiment of a closure system web used in the present invention.

            Fig. 2 is a top perspective cut away view of a portion of a closure system web such as shown in Fig. 1.

            Fig. 3 is a cut away schematic view of an apparatus for forming the closure system web of the invention such as shown in Figs. 1 and 2.

            Fig. 4 is a top perspective view of a second embodiment of a closure system web in accordance with the present invention.

            Figs. 5-7 are top perspective views of three further embodiments of closure system webs in accordance with the present invention.

15            Fig. 8 is a top perspective view of further embodiment of a closure system web in accordance with the present invention having a double width.

            Fig. 9 is a top perspective view of a further embodiment of a closure system web in accordance with the present invention.

            Fig. 10 is a top perspective view of a further embodiment of a closure system web in accordance with the present invention.

            Fig. 11 is a top perspective view of a further closure system web in accordance with the present invention.

            Fig. 12 is a top perspective view of a Fig. 11 embodiment as it would be applied to a web 41 forming a disposable absorbent article.

25            Figs. 13-15 are side cross sectional views of further embodiments of closure system webs in accordance with the present invention.

            Fig. 16 is a top perspective schematic view of how the closure system webs of the present invention would be cut out and applied as tab elements in the formation of disposable absorbent articles from a continuous web 41.

30            Fig. 17 is a top perspective view of a further embodiment of a closure web in accordance with the present invention.

Fig. 18 is a top perspective view of a further embodiment of a closure web in accordance with the present invention.

#### Description of the Preferred Embodiments

5           The instant invention is directed at providing a fully functional closure system for a disposable absorbent article, integrated with the process of forming the disposable absorbent article, by attachment of unitary closure system tab elements. The tab elements are cut from a continuous closure system web product and then attached to a continuous or substantially continuous absorbent article web from  
10           which discrete disposable absorbent articles are eventually cut. These closure system tab elements provide both the fastening tabs and a suitable mating attachment surface for the disposable absorbent articles. However the fastening tabs and mating attachment surface of a single closure system tab element end up on different absorbent articles when the absorbent articles are cut from the absorbent  
15           article web.

          A first embodiment of a closure system web product, in cross section, is shown in Fig. 1, which comprises a laminate of a backing layer (2) having a first face provided with a pressure sensitive adhesive layer (9). Adhesive layer (9) is used for eventual attachment of the closure system tab elements to the disposable  
20           absorbent article web. Attached to the backing (2) at terminal end portions are first fastening regions. In the Fig. 1 embodiment the first fastening region is provided by a hook mechanical fastening material (4) formed from hook mechanical fastening elements (7) projecting from a hook backing (6). However the fastening region can be formed directly on the backing (2) rather than being attached as a separate  
25           element by, for example, use of an adhesive as shown in Fig. 1. The second face of the backing (2) in Fig. 1 is provided with second fastening region comprising a mating loop mechanical fastening material (8) which would engage with the hook mechanical fastener material (4). These two mating fastening materials together  
30           form a unitary closure system when applied to a diaper web, or the like, in accordance with the invention.

The closure system tab elements (14) are cut from the continuous closure system web (1) along cut lines (15) as shown in Fig. 2. The closure system web (1), and the closure system tab elements (14) cut therefrom, have a width dimension (31) which is divided into terminal end portions (32) and a second portion(s) (33).  
5 Although the terminal end portions (32) can be at the side edges of the closure system web, as shown in Fig. 2, they can also be provided at intermediate regions of a closure system web as shown in Figs. 8 and 11. The closure system web (1), generally has an indefinite length direction (L), however, the closure system tab elements (14) cut from the web (1) generally have a definite length dimension (16)  
10 which is preferably constant across the majority of the width (31) of the closure system tab element (14), and is preferably constant over at least the entire second portion (33).

If closure system tab elements (14) vary in length (16) across their width, two separate cut lines must be provided to define the top and bottom of adjacent  
15 closure system tab elements. This requires material waste or selvage between the two separate cut lines. If a single tab element cut line defines both the top and bottom of two adjacent tab elements (14), there is no waste, but the length (16) of the tab elements will be constant across the width of the tab element along the shared boundary defined by the single tab element cut line (except possibly in the  
20 special case where the tab element cut lines are parallel to the length direction, in which case the width would include the length of the cut line). However, inevitably the tab element cut line is not straight and does vary in the length direction of the continuous web so that the terminal end portions (32) are offset from the second portion (33) in the length dimension. The average offset is at least 10 percent of the  
25 maximum length of the terminal end portions preferably at least 50 percent.

On the terminal end portion (32) is generally provided the first fastening region, which in the case of Fig. 2 is hook mechanical fastening material (4) which engages with a mating second loop mechanical fastening material (8) on an attachment portion of the second portion (33). In Fig. 2 the second fastening  
30 region forming the attachment portion is the loop material (8).

The closure system tab elements (14) when cut from the closure system-web (1) provide unitary structures which are attached to a continuous or substantially continuous web used in forming the absorbent articles at a location having the above first width. As shown in Fig. 16, the outer backsheet web of a diaper can form the continuous web. A continuous web, as shown in Fig. 16, is either assembled, or will be assembled, with other components to form a continuous disposable absorbent article web. From this disposable absorbent article web discrete disposable absorbent articles are cut. For example, these other components, in addition to the backsheet web, can include an absorbent batt material, a fluid permeable top sheet, a fluid transport layer or similar continuous or substantially continuous web elements which are conventionally integrated into the manufacture of a disposable absorbent article. Also, other discrete elements can be attached to the continuous web(s) such as further tab elements, elastics such as leg or waist elastics, liquid barriers, reinforcement elements, or the like.

The continuous web as shown in Fig. 16 is a backsheet web but other continuous webs could be used for attachment of the closure system tab elements; for example, nonwoven cover sheets, liquid pervious topsheets, or the like. Also, the continuous or substantially continuous web to which the closure system tab elements is attached could be nonplanar, laminated to other webs, or composites created by a lamination of multiple discrete components. A substantially continuous web can also be used having short regions of discontinuity creating web elements that generally are sequentially arranged and continuously supported, at least in the region where the closure system tab elements are attached. However, in this embodiment, when the closure system tab elements are attached to the discrete continuously supported web elements, the web elements and the attached closure system tab elements will form a continuous web at least in the region between where the closure system tab elements are attached and the discrete absorbent articles are cut and/or the closure system tab element are bisected.

In Fig. 2, the numeral (10) indicates the side edges of the at least one absorbent article continuous web (41) to which the closure system tab elements (14) are attached at discrete longitudinally displaced locations along the length of an at

least one absorbent article continuous web (41), as shown in Fig. 16. The continuous web (41) is then cut into discrete absorbent articles along transverse cut lines (11) which transverse cut lines generally also bisect or cut the closure system tab elements (14) as shown, e.g., in Figs. 2 and 16. However, it is possible to bisect the closure system tab element before cutting the discrete absorbent article by, for example, bisecting the closure system tab elements as part of a continuous web and attaching these discrete elements to a further web from which the discrete absorbent articles are eventually formed. When the discrete absorbent articles are cut, the terminal end portions (32) and a portion of the second portion (33) forming a bridging element or band (95 or 12) remain attached to a first disposable absorbent article (90) with a majority of the second portion (33) remaining on an adjacent disposable absorbent article (91), forming the attachment portion (93 or 13).

The terminal end portions (32) have a first end (17) which projects outwardly beyond the side edges (10) of the disposable absorbent article and a second end (18), which remains permanently attached to the disposable absorbent article web (41). At least a portion of the first end (17) contains the first fastening region, such as the hook material (4) in Fig. 2. The mating loop material (8) on the second portion (33) attachment portion (93 or 13), when attached to continuous web (41), forms the mating mechanical fastening surface on the adjacent absorbent article (91) which in conjunction with the next downweb closure system tab element terminal end portions (32) forms a unitary closure system on a disposable absorbent article (90).

Generally, the attachment portion (93) is attached to the front region (96) of a disposable absorbent article or the like. The terminal end portions (32) containing the first fastening region are attached to a back portion (97) of the disposable absorbent article. However, the front and back portions are determined by how the article is attached, which can be determined by the user. As such, the front portion could be used as the back portion if the absorbent article is generally symmetrical and the user so chooses.

The terminal end portions (32), provided generally on only a first side of the traverse cut line (11), form fastening tab portions (99) on a disposable absorbent

article. These fastening tab portions, as shown in Figs. 2 and 16, can be interconnected by, or include, a portion of the second portion (33). When these portions of the second portion (33) interconnect two fastening tab portions, they act as a bridging portion or band (12 or 95) around a front or back peripheral edge of the disposable absorbent article (91). Consequently, when the fastening tab portions (99) are attached to the attachment portion (13 or 93) a continuous band is formed around the peripheral edge of the disposable absorbent article formed by the front portion (96) and the back portion (97). This bridging portion or band (12 or 95) can be in whole or in part inextensible, extensible and/or elastic depending on the material forming the backing layer (2).

The bridging element or band (12 or 95) can provide functionality such as inextensibility if a suitable backing (2) is selected. Inextensibility is desirable in that the garment, such as a diaper, can permanently stretch when it is worn. This stretching results in a loose fit and possibly leakage, or even the diaper falling off. If a continuous inextensible band is provided around the diaper this stretching can be minimized or eliminated. Elasticity in the bridging element (12 or 95) can also address stretching by positively engaging the wearer around the waist, providing an elastic recovery force. In this case, all or a portion of the backing (2) is provided to be elastic, and the closure system tab elements (14) are applied in a manner as is conventional for a waist elastic or like elastic components.

Fig. 16 is a schematic illustration of a continuous web, of the disposable absorbent article (41), to which is attached the closure system tab elements (14) such as depicted in Figs. 1 and 2. The terminal end portions (32) when cut from the attachment portion (13 or 93) of the second portion (33) by the transverse cut line (11) forms two fastening tab portions (99), connected by a bridging element (95), at the terminal side edges (10) of the disposable absorbent article (91) cut from the web (41). The second portion (33) attachment portion (13 or 93) forms the mating attachment surface second fastening region to which the fastening tab portion (99) first fastening region adheres. The transverse cut line (11) bisects the closure system tab element (14) along its definite length dimension (16) such that a fastening tab portion (99) and bridging element (12 or 95) is on one side of the

traverse cut line (11), and the attachment portion (13 or 93) is on the second -  
opposing side of the traverse cut line. A unitary closure system is formed on a  
single disposable absorbent article (91) by the respective fastening tab portions (99)  
on a first side of the traverse cut line of a first closure system tab element (14) in  
5 combination with the adjacent attachment portion (93) cut from the second  
opposing side of a second adjacent closure system tab element (14).

Generally, the fastening tab portion maximum length is from 2 to 10 cm  
long, preferably from 2 to 5 cm long and from 2 to 20 cm wide, preferably from 5  
to 15 cm wide based on the size of the article. However, the first fastening region  
10 can be from 0.5 to 5 cm long on average, preferably from 1 to 4 cm long or  
arranged to provide a cross sectional area of from 0.25 to 25 cm<sup>2</sup>, preferably from 1  
to 10 cm<sup>2</sup>. The portion of the fastening tab portion permanently attached to the  
article includes the terminal end portion (32) second end and possibly a portion of  
the second portion (33). Overall, the minimum width of the fastening tab portion  
15 (99) second end permanently attached to the diaper is from 1 to 5, preferably from  
2 to 4 cm.

The overall length of the attachment portion (13, 93) is preferably at least  
40 to 95 percent of the length of the first fastening region, preferably 60 to 90  
percent. The length of the bridging element can vary across its width, as can the  
20 length of the attachment portion. The average length of the attachment portion can  
range from 5 to 100 cm, preferably from 10 to 50 cm. Overall, the maximum length  
(16) of the closure system tab element can vary as required and could be from 10 to  
200 cm, preferably from 20 to 100 cm. The bridging member length can be zero, or  
close to zero, where it provides no functionality as a continuous belt element.  
25 However if the bridging element functions as an elastic band or an inextensible band  
or the like, it is generally has a minimum length of at least 0.5 cm and generally at  
least 1 cm to 5 cm long. The bridging element average length generally is less than  
the average length of the attachment portion. Preferably, the average length of the  
bridging element is less than 40 percent of the average length of the attachment  
30 portion. The bridging element and the attachment portion, if combined, will  
generally form a rectangular shape, when the tab elements are separated by a single

cut line in the second portion. As such, the bridging element and the attachment portion are generally negative inverted mirror images of each other.

Fig. 3 illustrates a method for forming the closure system web of Figs. 1 and 2 having hook and loop fastening regions using the methods substantially described in U.S. Pat. No. 5,256,231 to form the loop fastening region. By this method, a sheet of fibers (3), which can be a non-woven web, used to form the loop material (8) is fed by conventional means, such as from a supply roll or directly from a web-forming process, between a pair of mutually parallel intermeshing rollers (25 and 26) which are provided with intermeshing teeth. These teeth intermesh in the manner of gear-teeth with ridges on one roll fitting into valleys on the adjacent roll, and visa versa. As shown in Fig. 3, these intermeshing teeth can be aligned radially along the length of rollers (25 and 26), however, these gear teeth could also be arranged in numerous other regular intermeshing patterns including circumferentially extending gear teeth along the diameter of rollers (25 and 26), or in mating geometric patterns such as diamonds, hexagons, squares, circles, or any other regular or irregular pattern where the peak portions of a pattern on one roll intermesh with the valley portions of a pattern on the adjacent roll. Upon exiting from the nip (24) formed by rolls (25 and 26), the sheet of fibers is retained along the periphery of the roll (26) such as by applying web tension, vacuum, differentially heating roll (26) and /or roughing the surface of roll (26). At this point, the sheet of fibers (3) is maintained in its deformed or corrugated state and is given dimensional stability by joining with a dimensionally stable web material such as a film or a dimensionally stabilized woven or non-woven fabric. Alternatively the corrugated sheet of fibers can be made to be elastic or extensible by being joined to an elastic or extensible web material which web material can form the closure system web backing (2).

As shown in Fig. 3, the corrugated loop material (8) retained on the surface of roll (26) is directly joined to a molten extruded film material (23) which is formed in a die provided with a die opening (22). The extruded film material (23) being still in a molten, or semi-molten condition is sufficiently soft to allow the sheet of fibers (3) corrugated on roll (26) to become embedded within the extrudate. This

and/or by suitably nested cut patterns as shown in Fig. 8. The curved side edge (30) of the first end (37) eliminates or reduces the presence of sharp corners which can cause discomfort for the wearer of the disposable absorbent article if such sharp corners come in contact with the skin. The first end (37) containing the at least first fastening region hook material has an average length (36). The fastening tab portion (34) on terminal end portion (32) first end (37) is preferably provided so that no sharp corner portions extend out beyond the edge (10) of the continuous web (41) used in forming the disposable absorbent article (91). In that, the length of the closure system tab element (14) varies in the first end (37), there is a need for diverging cut lines in this region which requires waste or selvage of a certain portion of closure system web material in the first end region in this embodiment.

Fig. 5 depicts a variation of the Fig. 4 embodiment where the tapered region (5) of the cut pattern of the closure system web (1) has shifted outward slightly at the top portion. Also, the loop material (8) and/or the sheet of fibers has been extended outward so that it covers the entire terminal end portions, from which are formed the fastening tab portions (34).

Fig. 6 shows a further embodiment similar to that shown in Fig. 4, where there is shown a cut out region or selvage (42) to be removed from the terminal end portions of the closure system web (1). In this embodiment, the cut line (45) in the second portion (33) is in the form of a substantially continuous arc forming a generally semi-circular attachment portion (46). The bridging portion (40) interconnecting the two terminal end portions (47) is a corresponding concave structure.

Fig. 7 illustrates a further embodiment of a closure system tab element designed in accordance with the invention wherein the attachment portion (56) is in the shape of a rectangle, also providing a rectangular bridging element or band (50) from the second portion (33). The individual closure system tab elements (14) are cut along the tab element cut line (55) providing fastening tab portions with a curved edge (30) on the first end (17) and a rectilinear second end (18).

The embodiment shown in Fig. 8 shows an alternative for producing rounded edge (30) fastening tab portion first ends on a multiple width closure

system web provided with multiple terminal end portions and second portions. With the terminal end portions at the outside edges of the closure system web the fastening tab portion curved side edges (30) are still provided by removal of selvage material. However, with intermediate terminal end portions, two nested curved side edges (30) can be provided by a single sinusoidal or like undulating cut line as shown in Fig. 8. The Fig. 8 embodiment results in two secondary closure system webs (56) cut from a single multiple width primary closure system web. The two secondary closure system webs (56) can be simultaneously or subsequently cut into closure system tab elements (14), as disclosed in the other embodiments of the invention.

As shown in Fig. 8, the intermediary terminal end portions curved side edges are provided by a single sinusoidal or like undulating cut line such that the fastening tab portion first ends having the first fastening regions nest without any wasted material or selvage. However, if desired, an intermediate waste or selvage region can be provided, particularly where the first fastening region is asymmetrical across its width dimension. For example, the base of the fastening tab portion first end and/or the first fastening region can be distinct and different from the outer tip of the fastening tab portion first end. In the Fig. 8 embodiment, the curved portion of the fastening tab portion first end is symmetrical in that a continuous first fastening region is provided across the entire width of the curved portion of the fastening tab portion first end. An asymmetrical fastening tab portion first end could also be provided. For example, the first end could be provided with two distinct different attachment regions along its width, such as a combination of a mechanical fastening region with an adhesive fastening region. Alternatively, a single region with no fastening means could be provided such as a finger lift region at the tip of the first end which region is not reciprocally provided at the base of the fastening tab portion first end. These and other asymmetrical fastening tab designs cut from a multiple width closure system web would generally require the provisions of two adjacent terminal end portions first ends in the central portion of the closure system web with separate cut lines for each to provide the desired asymmetrical fastening tab portions first ends on the two or more secondary closure system webs.

provides secure bonding and also dimensional stability or other properties based on the properties of the film backing (23) and any further layers provided (not shown). The backing roll (27) forms a nip with roll (26), which roll (27) is generally a cooled, smooth roll. The nip pressure is preferably substantially constant across the width of the laminated web material formed at least by the corrugated sheet of fibers (8) and the extrudate (23). Additional cooling rollers could be provided or the laminate could be further wrapped around roller (27) to provide further cooling as desired. The laminate backing (2) is then further coated with adhesive (9) using an adhesive coater (29), which can be a pressure sensitive adhesive. Adhesive (9) can then be used to adhesively bond the mechanical fastening material (4) to the backing (2). The mechanical fastening material (4) can also be previously adhesively coated and then joined with the laminate web backing (2) or attached by other mechanisms including sonic bonding, point bonding, sewing, or the like.

If a pre-formed web material is provided as the backing (2), the nip (28) formed between rolls (26 and 27) is preferably heated so as to thermally bond the sheet of fibers (8) to the pre-formed backing materials, such as by providing rolls (26 or 27) with heating elements such as an oil heated roll, a water heated roll, an induction heated roll, or an ultrasonic horn.

An alternative embodiment of providing the invention closure system tab elements (14) is depicted in Fig. 4, with the fastening tab portion (34) first end (37) on the terminal end portion (32) provided with smooth outer side edges (30). The closure system tab elements (14) are also cut into a slightly modified form along the cut pattern (35) by providing a region (5) where the cut line pattern slowly tapers from a portion (46) of the cut line separating two adjacent terminal end portions to an offset portion (47) of the cut line (35) separating the attachment portion from the bridging portion (38). In this embodiment, again the substantially constant length (16) of the closure tab element (14) extends across the majority of the width of the closure tab element (14) and over the entire width of the second portion (33). However, the fastening tab portion (34) or terminal end portion (32) first end (37) tapers in length. The tapered first end (37) on the terminal end portion (32) can be formed by removing a portion of the terminal end portion such as shown in Fig. 6

In the embodiment depicted in Fig. 9, the cut out fastening tab portion first end has been folded back onto the closure system web, which can be done simultaneously with or following cutting out of the closure system tab elements. The fastening tab portion first end is preferably folded along the lines separating the first end from the second end where the first end is designed to removably adhere to the mating second fastening region on the attachment portion and the second end is designed to permanently attach to the disposable absorbent article. The Fig. 9 embodiment again is exemplified using a hook and loop type mechanical fastening closure system for the first and second fastening regions.

10 An alternative to the Fig. 9 embodiment is shown in Fig. 17 wherein the fastening tab portion first end provided with the first fastening region is folded away from the second fastening region rather than toward it. In this case, the fold is preferably away from the line separating the fastening tab portion first end and second end. The folded portion of the fastening tab portion first end is preferably  
15 entirely within a nonfolded portion of the fastening tab portion first end. This ensures that the folded portion does not get between the backing and the disposable absorbent article when the tab element is attached.

Fig. 18 is an alternative of the invention where the tab element is in a general chevron form. This embodiment would not have a bridging element and the second  
20 portion would have a general v-shape when on the disposable absorbent article.

Fig. 10 is an alternative embodiment of the invention where two first fastening regions (71) and (72) are provided, both in this case hook mechanical fastening regions; one at the terminal end portion first end (17) and a second at the outer side margins (61) of the attachment portion (60) in the second portion (33).  
25 The first fastening region (71) provided at the terminal end portion first end (17) would be on a first face of the backing, whereas the second first fastening region (72) would be provided on a second face of the backing adjacent the attachment portion (60) on the second portion (33).

In the Fig. 10 embodiment, the two first fastening regions (71 and 72) are  
30 provided by hook mechanical fastening material with the second fastening region provided by loop mechanical fastening material which forms the attachment portion

for the first fastening region (71) on the terminal end portion first end (17). The second first fastening region hook mechanical fastening material (72), provided adjacent the attachment portion (60), on the second portion (33) can be used to interengage with suitable loop or non-woven materials provided on a face of the disposable absorbent article opposite that attached to the terminal end portion or fastening tab portion second end (18). This suitable loop or non-woven material is generally located on a side edge region of the disposable absorbent article adjacent or subjacent to the region of the article attached to the second end (18) of the fastening tab portion and can be a separately applied loop material or a nonwoven topsheet type material.

Generally, in the above described embodiments, the overall shape of the closure system tab elements is a v or u, or like shape, however, other shapes are possible, including w-shapes.

Fig. 11 depicts an alternative embodiment of the invention wherein the terminal end portions are provided in a central region of a closure system web. The fastening tab portion first end on the terminal end portion is symmetrical in Fig. 11 so a single cut line can be used to form the first end curved end side edge (30) as described above relative to the Fig. 8 embodiment. The fastening tab portion is provided with a region (61) which is substantially free of fastening elements to provide a finger lift region (62). In the Fig. 11 embodiment, the two opposing closure system tab elements (63) and (64) cut from the closure system web are mirror images of each other; one providing the fastening tab portion and the attachment portion on one edge region of a disposable absorbent garment; and the opposing tab element providing an opposing fastening tab portion and an attachment portion on the opposite edge of the disposable absorbent article. With this embodiment, there are two separate and distinct attachment portions (65) and (66) and no bridging portion or band connecting the two terminal end portions or fastening tab portions.

Fig. 12 illustrates how the Fig. 11 closure system tab elements (63) and (64) would be placed on the continuous web (41) forming a portion of the disposable

absorbent article providing two separate attachment portions (65) and (66) and two fastening tab portions.

Although the first fastening regions depicted in the above illustrated embodiments are provided by a mechanical fastening element, particularly a hook  
5 mechanical fastening material (4), attached to the backing (2) by a provided pressure sensitive adhesive layer (9), the first fastening region can be provided by other attachment materials or in other ways. Specifically, the first fastening region can be any suitable attachment material including hook or loop mechanical fastening materials or regions, pressure sensitive adhesive regions or patches, cohesive  
10 adhesive regions or patches, and the like. Also other mechanical fastening type materials are possible, such as snap fasteners, provided that a suitable mating engagement surface is provided on the attachment portion on the opposite face of the closure system web. Further the first fastening region can be provided as a separate element attached to the backing (2) first face as shown in the drawings or  
15 can be integrally formed with the backing (2), for example, the backing could be an extruded film material with molded hook fastening elements provided only at the terminal end portions thereof. Alternatively, the first fastening region can be provided on a separate backing (6) which is attached to backing (2) by suitable methods, such as hot melt or pressure sensitive adhesives(as shown), heat or sonic  
20 welding, or other conventional means.

Where the first fastening region is provided by a pressure sensitive adhesive it is not necessary that the surface to which the first fastening region attaches be a surface provided by the second fastening region. For example, the closure system tab elements could be attached to an inside surface of a continuous backsheet web  
25 such that the first fastening region would attach to the backsheet web, or further web on a backsheet web, with the second fastening region of the closure system tab element reinforcing the backsheet web at a location where the first fastening region would attach to form a suitable tape fastening region. In this embodiment, the backing second face could be provided with a suitable pressure sensitive adhesive  
30 for attaching to the face of the, e.g., inside backsheet web. Alternatively, the

backing second face could be attached to the backsheet web or a further web by other attachment methods as previously discussed.

The backing (2) for the closure system web (1) can be any suitable web product or laminate including film materials, foam products, fabrics, such as woven or non-woven webs, or multi-layer structures comprising any or all of the above-mentioned materials and the like, which multi-layer structuring can be either continuous or intermittent across the length and/or width of the backing (2). The backing (2 or 82) could be an elastic material with specific elastic region, such as (81) depicted in Fig. 13. This elastic region (81) can be provided by specifically elasticating a region of the backing (2 or 82). In Fig. 13, the elastic backing (82) is formed as described in U.S. Patent No. 5,505,852 which discloses a coextruded inelastic multilayer film having elastic (86) and inelastic layers (85 and 87) which multilayer film can be selectively stretch activated to create an elastic, e.g., by selectively stretching in region (81) in the manner disclosed in U.S. Pat. No. 5,505,852. However, alternatively, the entire backing (2 or 82) can be made elastic such as by providing an elastomeric film or an elastomeric woven or non-woven material, or laminates thereof, as the backing (2 or 82). In Fig. 13, the hook fastening material (4) is attached to an inelastic portion of the backing (82) by an adhesive layer (89) which could be provided or coated on the hook material (4) or on the backing (82).

An alternative method of providing a zone of elasticity (81) on a film backing is shown in Fig. 15. In Fig. 15, the film backing is formed by selective side by side elastic and inelastic regions, for example, by side by side coextrusion of elastic and inelastic materials as disclosed in Japanese Appln. No. 8-187113. Alternatively, a side-by-side elastic and inelastic region could be provided by included elastic regions within an inelastic matrix as disclosed in U.S. Pat. No. 5,429,856.

An elastic backing material (12 or 82) can also be selectively bonded or laminated to an inelastic film or other web material in an unextended state followed by selective stretching of the composite to provide elasticity as disclosed in U.S. Pat. Nos. 5,167,897; 5,156,793; 5,143,679; or 5,527,304, or PCT WO 96/1048

(stretching is facilitated by selectively slitting the inelastic layer) or an elastic material can be applied to a separate backing layer (e.g., a non-woven web) in a stretched state either by intermittent or continuous attachment so as to allow the elastic material to recover resulting in the laminate backing material of the laminate backing so formed gather or buckle between attachment points forming an elastic composite in that region. Separately applied elastic material can also be applied to either the first or the second face of another continuous backing material which can also be elastic or inelastic, which other continuous backing could be stretched, unstretched or gathered, or corrugated when attached to the elastic material.

10           The loop materials (8) or (88) can be any conventional woven or non-woven loop material which is suitably attached to the backing (2) or (82) as would be known in the art.

          Fig. 14 shows an alternative embodiment of the invention where a loop fabric is selectively provided to be engagable with a hook material in region (83) and generally less engagable with the hook material in region (84). Loop fabric is applied to a film backing (82). This can be accomplished by taking a relatively low loft non-woven type fabric and causing it to selectively gather or corrugate in region (81) and be substantially flat in region (84) which region (84) can further be consolidated as required. This can be accomplished by using the method depicted in Fig. 3 by selectively providing corrugations or undulations in the web (3) only in the region or the second portion forming the attachment portion on the second face of the closure system web. Suitable non-woven materials for forming the loop material are disclosed, for example, in U.S. Pat. Nos. 5,256,231; 5,614,281; 5,032,122; 5,470,417; 5,326,612, and WO 96/04812, WO 95/33390.

25           Fig. 15 shows an alternative embodiment where a backing (107) is side-by-side coextruded to have inelastic regions (104 and 106) on either side of an elastic region (105). Further, an inelastic region (106) are formed integral hook elements. An inextensible web (103) is attached to first face of the backing and in at least elastic region (81) is corrugated by the method shown in Fig. 3 or otherwise compressed in its width dimension as is shown in the art. On the second face of the backing is provided a loop material (108) which is shown as corrugated by the

method shown in Fig. 3 across its full width allowing the elastic region (8) to elongate and provide a substantially loop attachment portion.

The invention further provides a method of forming a closure system for a disposable absorbent article comprising the steps of, providing at least one continuous or substantially continuous web capable of forming a portion of a disposable absorbent article. This web has at least a first width dimension defining two side edges and an indefinite length dimension. A closure system web is also provided comprising at least one backing having a first face and a second face. The closure system web has a second width dimension greater than the first width dimension and an indefinite length. The first face of the closure system web is provided with at least one first fastening region at at least one terminal end portion of the closure system web. At least one second fastening region is provided on the second face of the closure system web in at least the second portion adjacent the terminal end portion provided with the first fastening region. Closure system tab elements are cut from the closure system web which tab elements have a definite length dimension. The closure system tab elements have at least one fastening tab portion, comprising the at least one first fastening region on the terminal end portion, and an attachment portion comprising the second portion having the second fastening region.

The closure system tab elements are then attached to the at least one continuous or substantially continuous web at regular spaced intervals in the indefinite length dimension in a continuous manner forming a second continuous web. The second continuous web is then cut along transverse cut lines in the indefinite length dimension. The cut lines are such that they bisect the closure system tab elements along the tab element definite length dimension, so that the fastening tab portion is on a first side of the cut line and the attachment portion is on a second opposing side of the cut line. This provides fastening tab portions on a first end of one absorbent article and an attachment portion on a second end of an adjacent absorbent article. Preferably the transverse cut line also forms the discrete absorbent article.

We Claim

1. A method of forming a closure system for a disposable absorbent article comprising the steps of:

5 providing at least one continuous or substantially continuous web, the web capable of forming a portion of a disposable absorbent article, the web having a first width dimension defining two side edges and an indefinite length dimension,

10 providing a closure system web comprising at least one backing having a first face and a second face, a second width dimension and an indefinite length, the first face being provided with at least one first fastening region at at least one terminal end portion of the closure system web, at least one second fastening region being provided on the second face of the closure system web in a second portion adjacent the terminal end portion provided with the first fastening region,

15 cutting closure system tab elements having a definite length dimension from the closure system web, the closure system tab elements having at least one fastening tab portion, comprising the at least one first fastening region on the terminal end portion, and an attachment portion comprising the second portion having the second fastening region wherein the first fastening tab portion is offset from the attachment portion in the length direction,

20 continuously attaching the closure system tab elements to the at least one continuous or substantially continuous web at a location having the first width dimension at regular spaced intervals in the indefinite length dimension of the at least one continuous or substantially continuous web,

25 cutting the at least one continuous web along traverse cut lines to the indefinite length dimension to, wherein the traverse cut lines are such that each bisects the closure system tab element along its definite length such that the at least one fastening tab portion is on a first side of a traverse cut line and the offset attachment portion is on a second opposing side of

30

the traverse cut line so as to provide a fastening tab portion on the first end of one absorbent article and an attachment portion on a second end of an adjacent absorbent article.

5    2.     The method of claim 1 further comprising joining the at least one continuous or substantially continuous web to further elements to form a continuous absorbent article web and wherein the transverse cut line forms discrete absorbent articles and the at least one first fastening tab portion attached to the absorbent article has a first end extending outwardly beyond the side edges of the absorbent article and a  
10   second end attached to the absorbent article, at least the first end having said first fastening region.

3.     The method of claim 2 wherein there are two terminal end portions which are connected by a portion of the second portion on the first side of the traverse cut  
15   line, the second portion on the first side of the traverse cut line has an average length less than average length of the second portion on the second side of the cut line, the average width of the second portion on the first side of the traverse cut line is greater than the average width of the second portion on the second side of the traverse cut line, the average length of the second portion on the first side of the  
20   traverse cut line is less than 50 percent of the average length of the second portion on the second side of the traverse cut line.

4.     The method of any of claims 1-3 wherein the second portion on the first side of the traverse cut line is a negative inverted mirror image of the second portion on  
25   the second side of the traverse cut line for a closure system tab element such that the two second portions if combined would form a rectangular second portion.

5.     The method of any of claims 1-4 wherein the first fastening region comprises a pressure sensitive adhesive patch or a mechanical fastening patch where  
30   the attachment portion comprises a mating mechanical fastening patch.

6. The method of any of claims 1-5 wherein the terminal end portions are between two second portions on the closure system web such that two closure system tab elements are cut from left and right edges of the closure system web, one closure system tab element from each edge of the closure system web are placed  
5 along each edge of the continuous web forming the disposable absorbent article such that each traverse cut line forms two fastening tab portions and two attachment portions on adjacent absorbent articles.

7. A closure system for a disposable absorbent article comprising a disposable  
10 absorbent article having a first width dimension defining two side edges and two end edges, a closure system comprising at least one fastening tab having a backing having a first face and a second face and a top edge and a bottom edge, the first face being provided with at least one first fastening region at at least a first end, and at least one second fastening region on an attachment portion having a backing, the  
15 at least one attachment portion having a top edge and a bottom edge, at least a discrete portion of the at least one attachment portion top edge being laterally coextensive with a portion of the at least one fastening tab bottom edge wherein at least at an area adjacent the two discrete edge portions of the at least one fastening tab and the attachment portion the respective backings are identical.

20

8. The closure system of claim 7 wherein the at least one fastening tab bottom edge is coextensive with a portion of a first end edge of the disposable absorbent article.

25 9. The closure system of any of claims 7 and 8 wherein the at least one attachment portion top edge is coextensive with a portion of a second end edge of the disposable absorbent article.

10. The closure system of any of claims 7-9 wherein the at least one first  
30 fastening tab portion attached to the absorbent article has a first end extending

outwardly beyond the side edges of the absorbent article and a second end attached to the absorbent article, at least the first end having said first fastening region.

11. The closure system of any of claims 7-10 wherein the at least one fastening  
5 tab portion comprises two fastening tab portions which are connected by a bridging  
portion, at least a portion of the bridging portion forming the coextensive discrete  
edge portion of the at least one fastening tab coextensive with the second top edge  
of the disposable absorbent article, where the bridging portion has an average length  
less than average length of the attachment portion, and the average width of the  
10 bridging portion is greater than the average width of the attachment portion.

12. The closure system of claim 11 wherein the bridging portion is a negative  
inverted mirror image of the attachment portion such that the two portions if  
combined would form a rectangular portion.

15

13. The closure system of any of claims 7-12 wherein the first fastening region  
comprises a pressure sensitive adhesive patch, or a mechanical fastening patch in  
which case the second fastening region on the attachment portion comprises a  
mating mechanical fastening patch wherein a face of the backing of the attachment  
20 portion is attached to an outer surface of the disposable absorbent article and an  
opposite face of the backing is provided with the mating mechanical fastening patch.

14. The closure system of claim 13 wherein the first fastening region comprises a  
hook mechanical fastening patch and the mating mechanical fastening patch  
25 comprises a loop mechanical fastening patch.

15. The closure system of any of claims 1-14 wherein the first face of the at  
least one fastening tab backing is provided with a pressure sensitive adhesive for  
attachment of the at least one fastening tab to the disposable absorbent article.

30

16. The closure system of any of claims 1-15 wherein the two fastening tabs and the bridging portion are in a general u-shape.
17. The closure system of any of claims 1-16 wherein at least the fastening tab portions are provided with elastic regions outboard, of the disposable absorbent article.
18. The closure system of any of claims 7-17 wherein the first fastening region is a hook mechanical fastener on the first end of the fastening tab portion with the second end of the fastening tab portion on the first face having a mating loop material for temporary attachment of the hook mechanical fastener prior to use.
19. The closure system of any of claims 7-17 wherein there are two separate attachment portions.
20. The closure system of any of claims 7-19 wherein the maximum length of the fastening tab is from 2 to 10 cm, the fastening tab first fastening region is on average from 0.3 to 5 cm long, the fastening tab first fastening region has a cross sectional area of from 1 to 10 cm<sup>2</sup>, the fastening tab second end has a minimum width of from 1 to 5 cm, and the attachment portion average length is from 40 to 95 percent of the average length of the first fastening region.

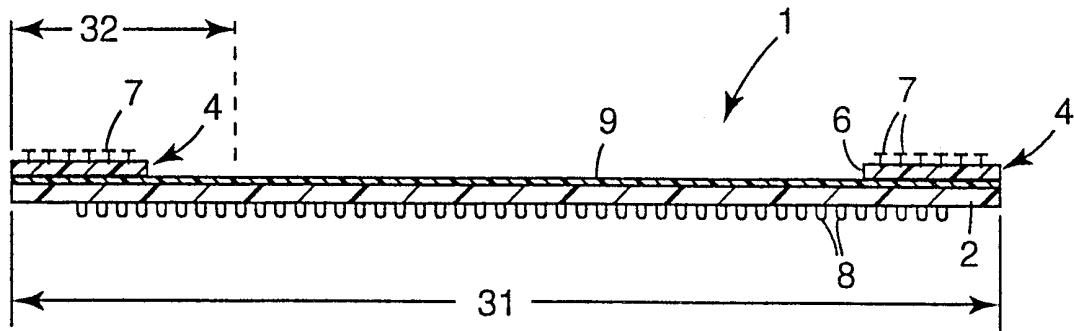

Fig.1

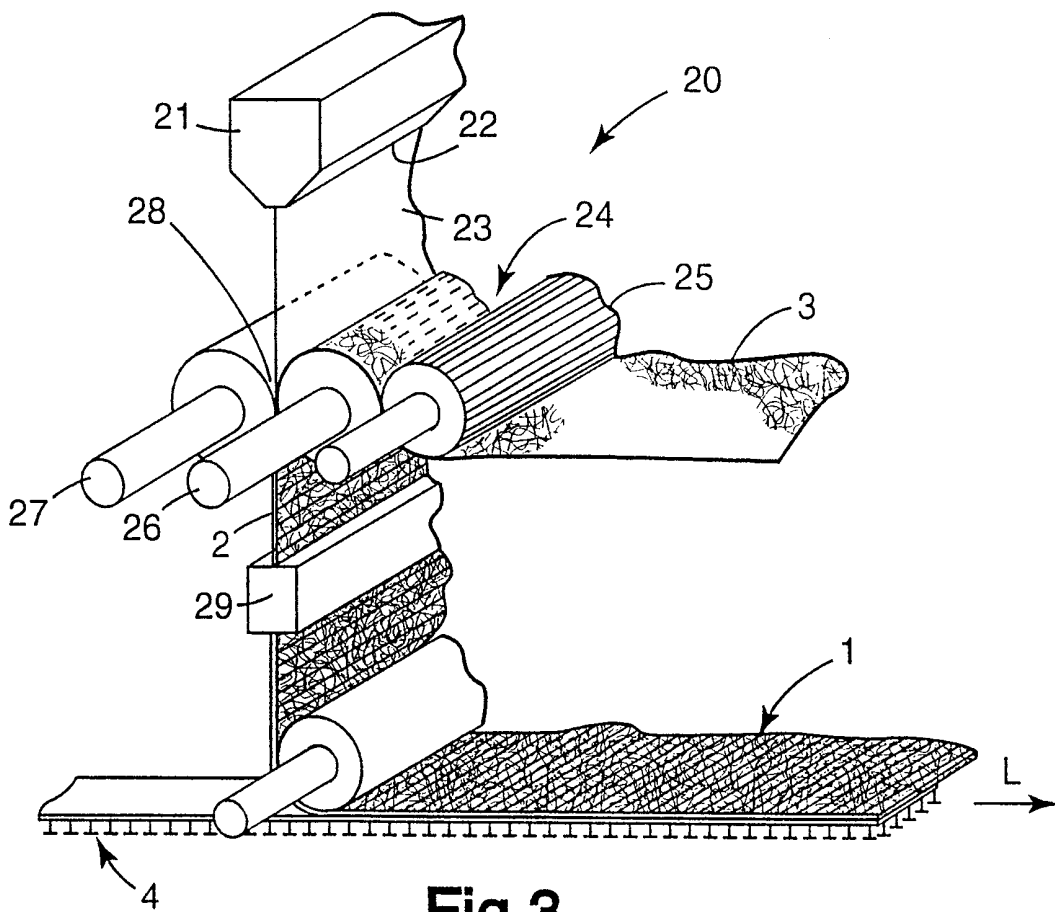

Fig.3

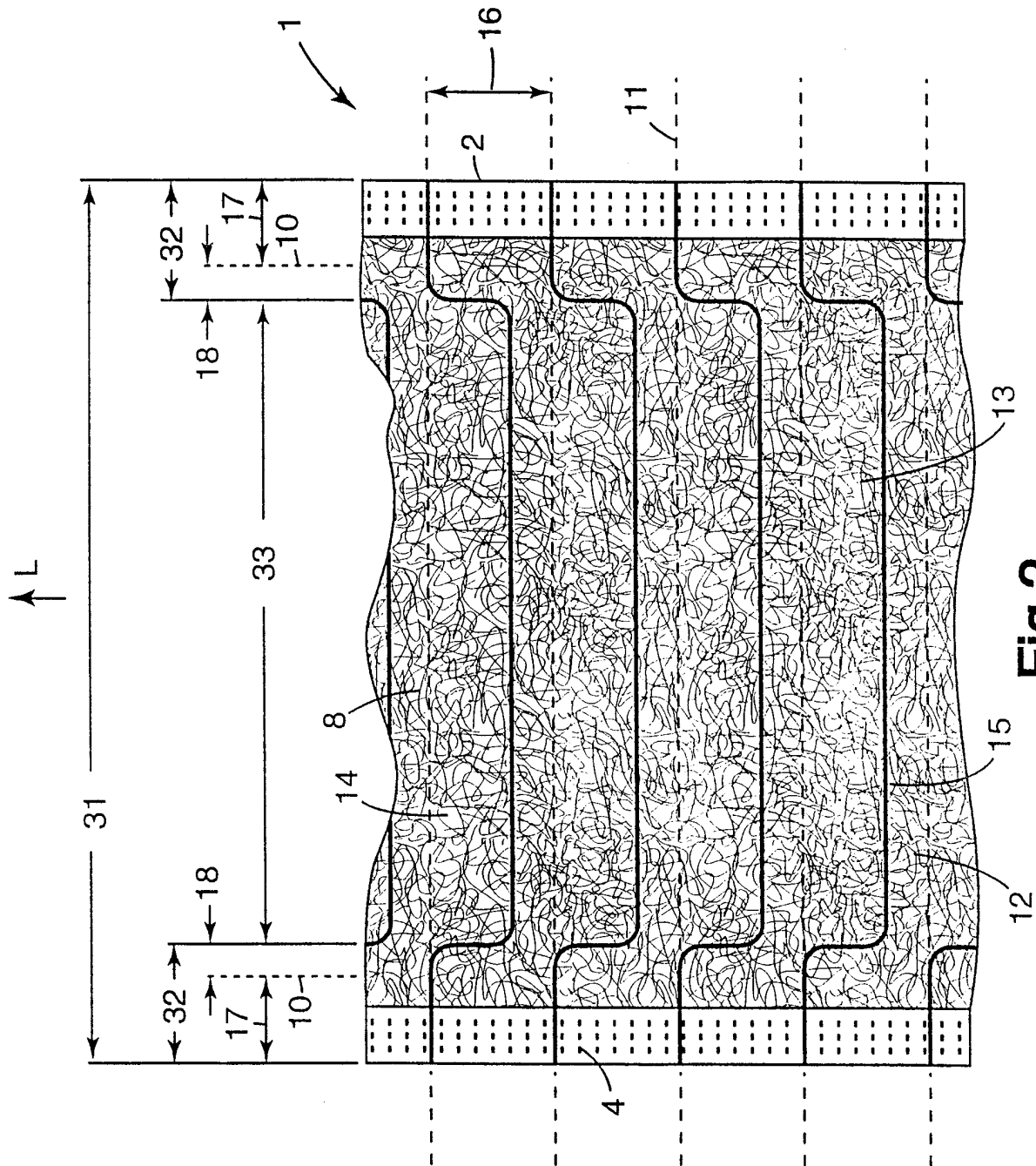

Fig. 2

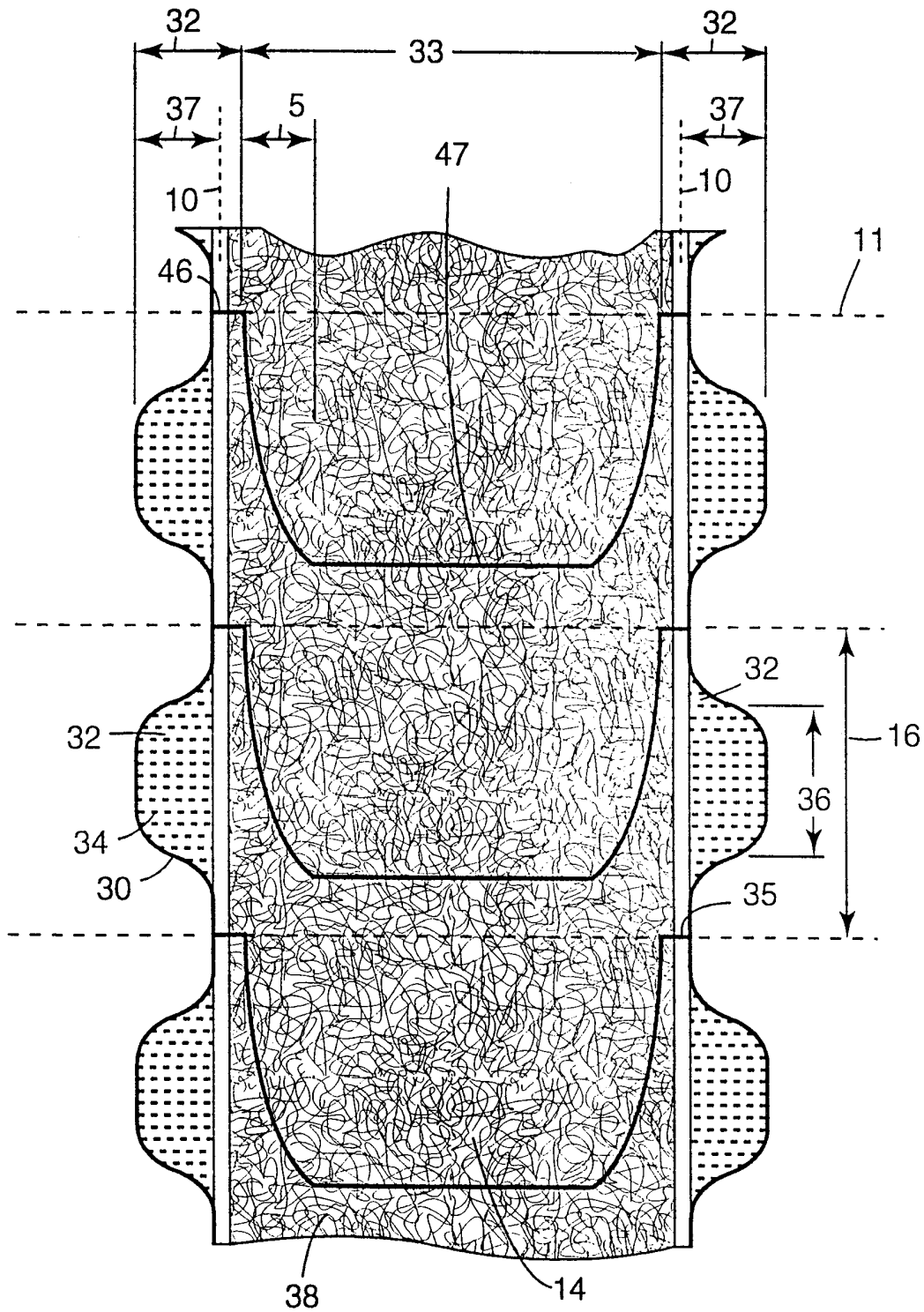
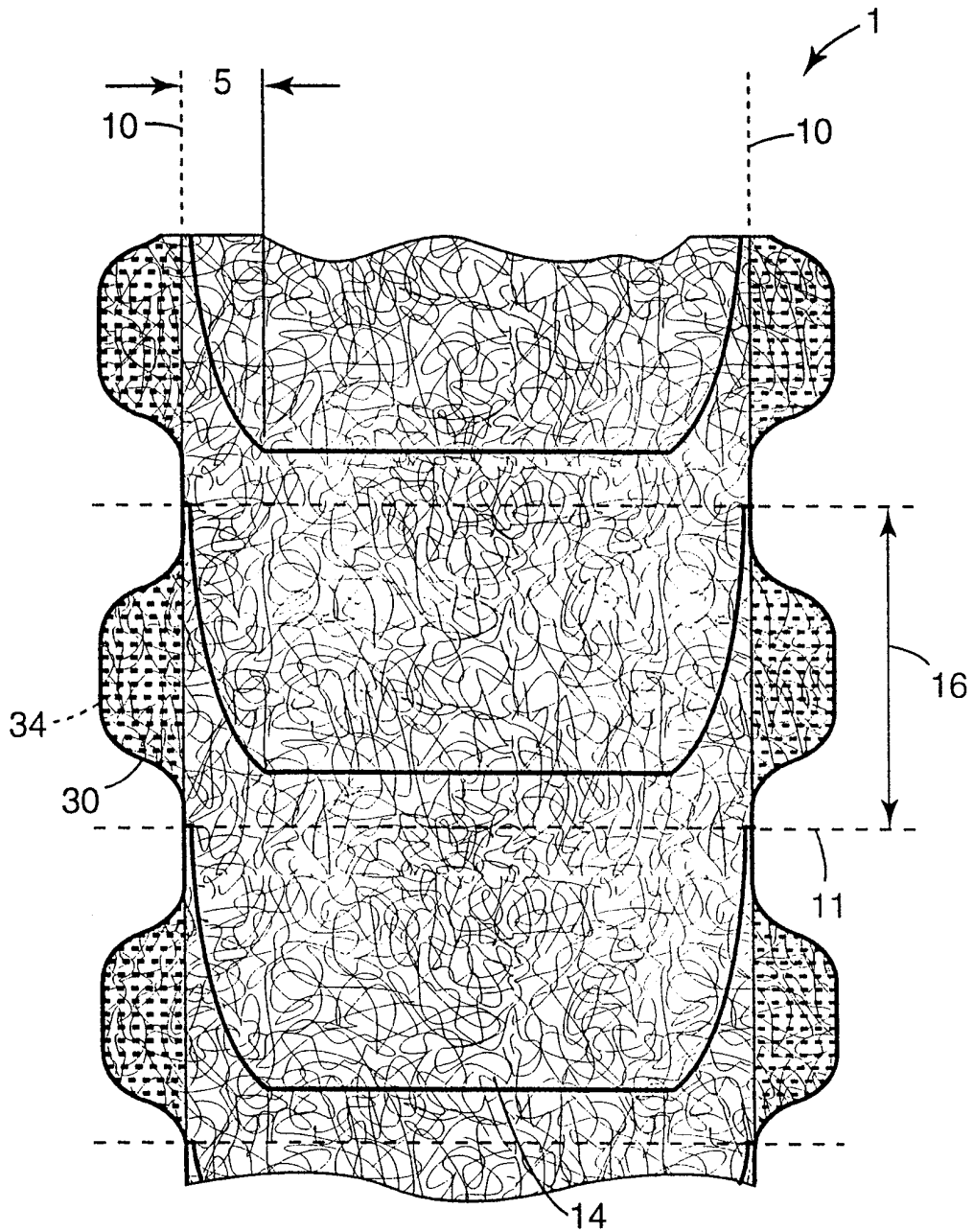
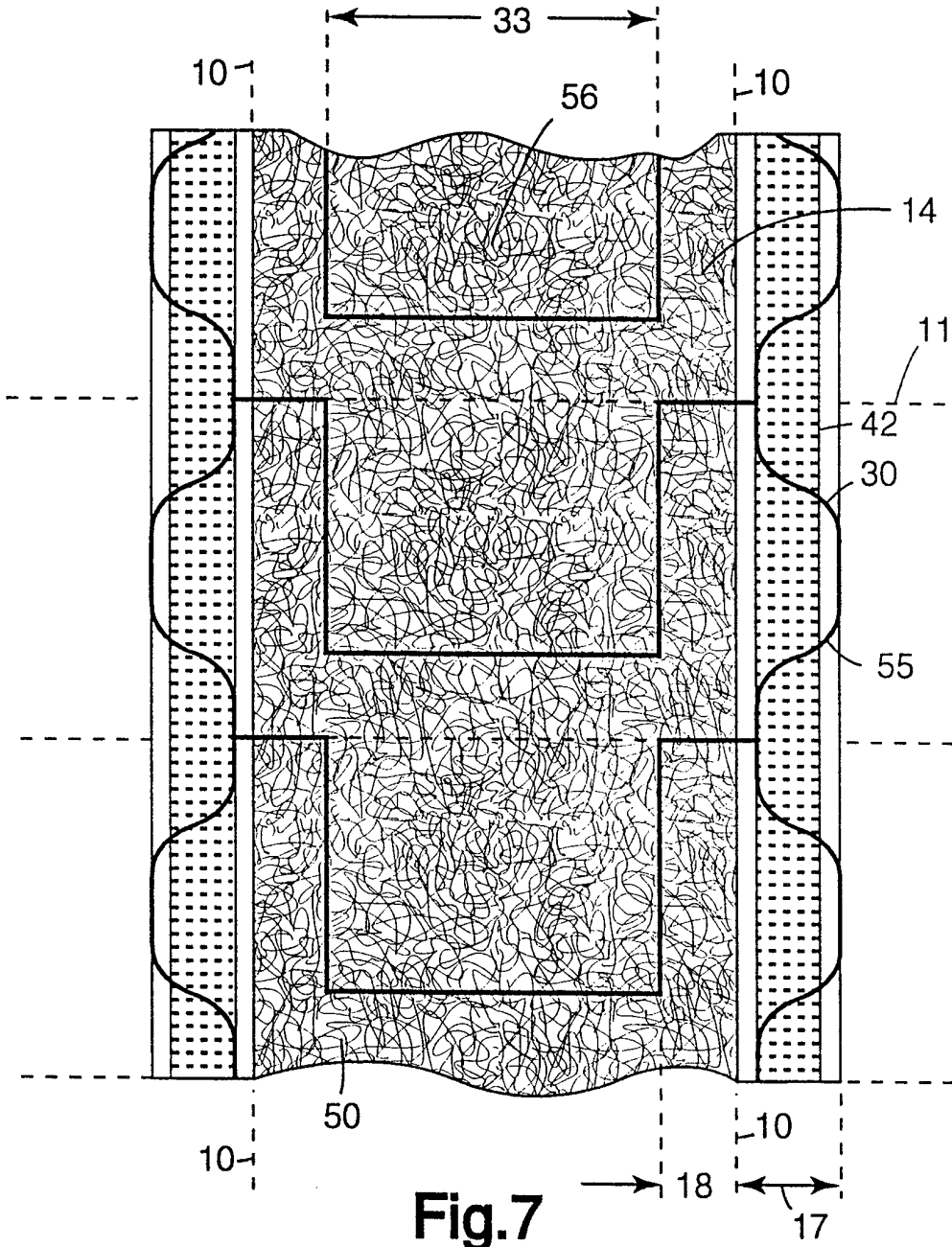

Fig.4



**Fig.5**





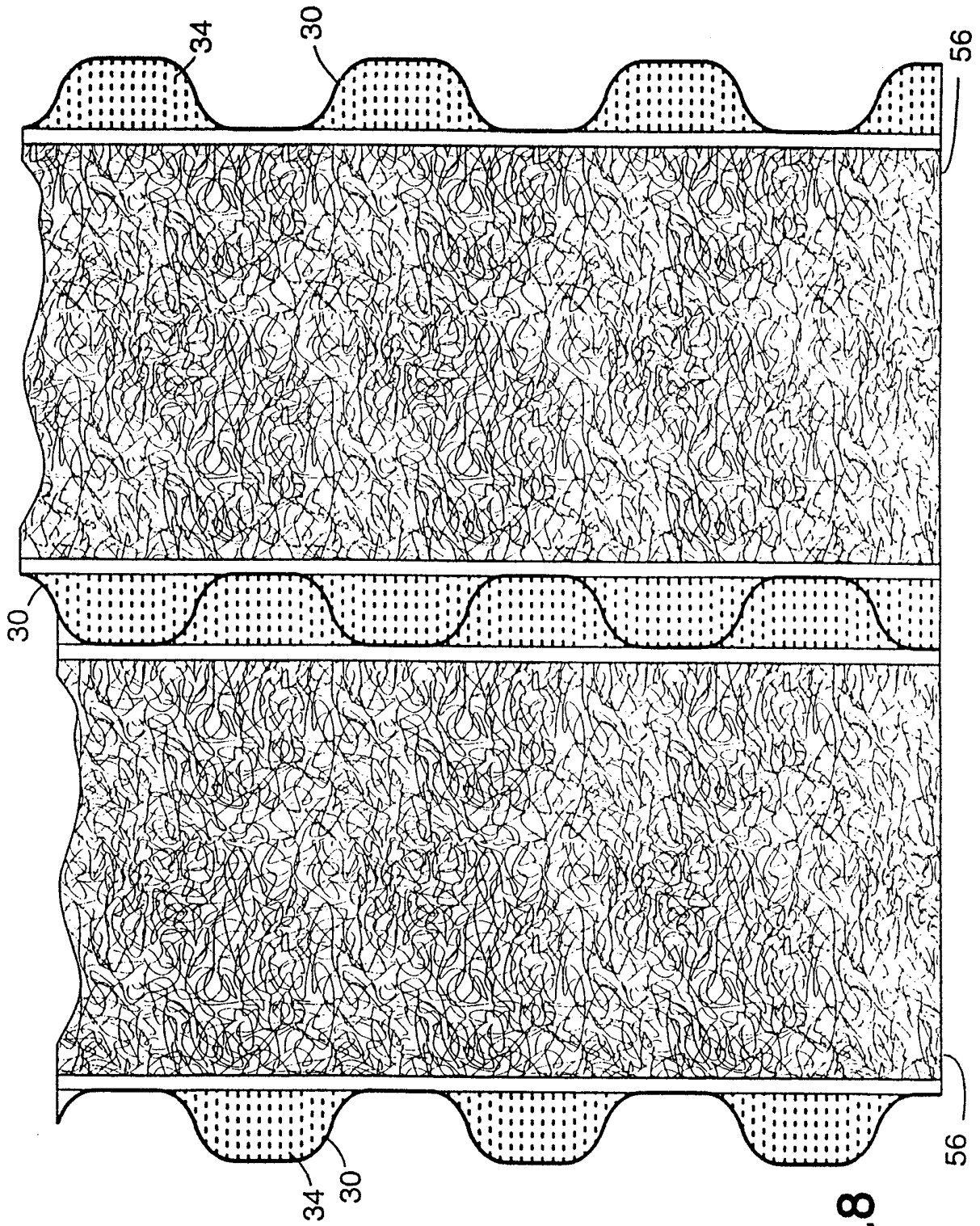
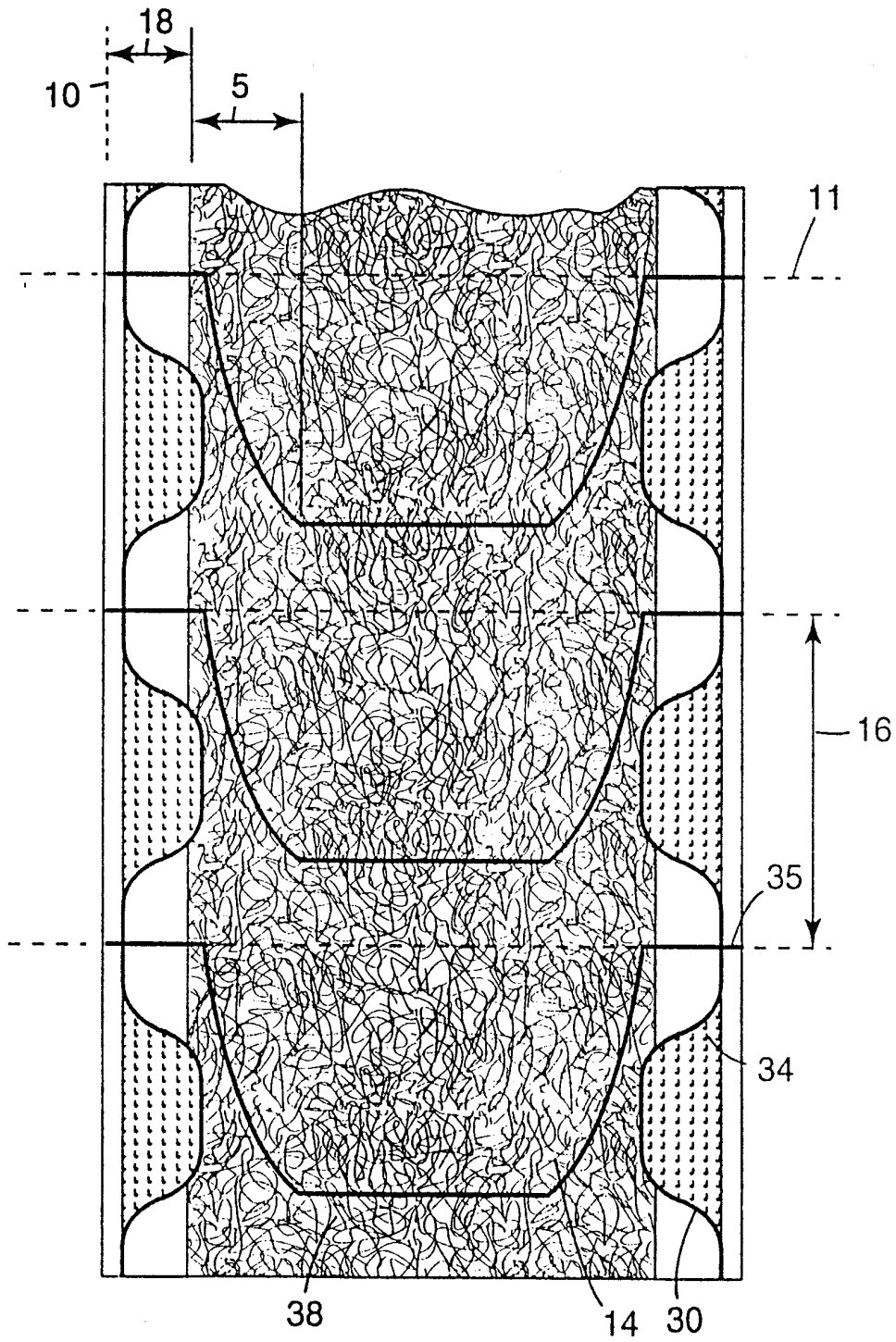

Fig.8



**Fig.9**

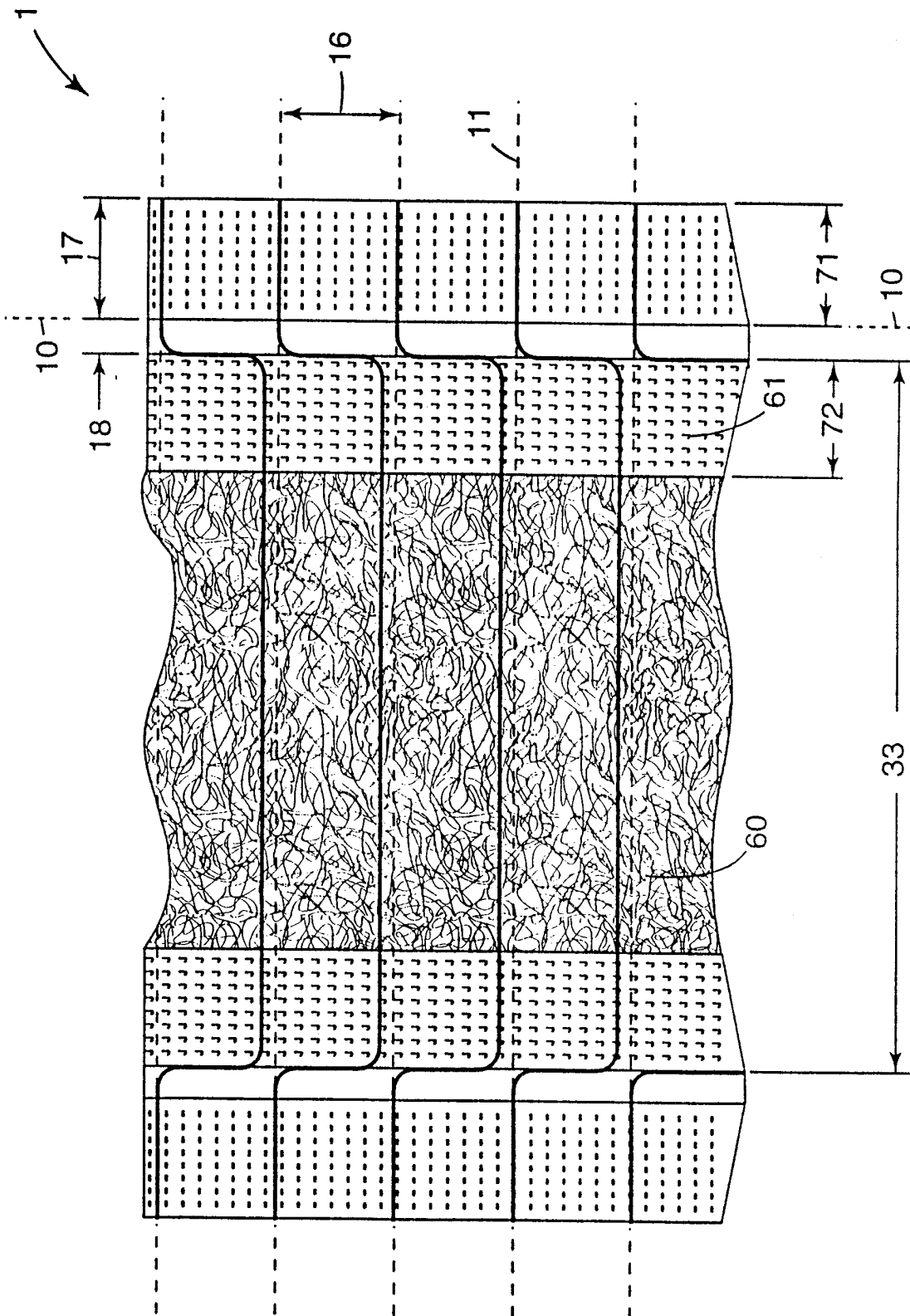

Fig.10

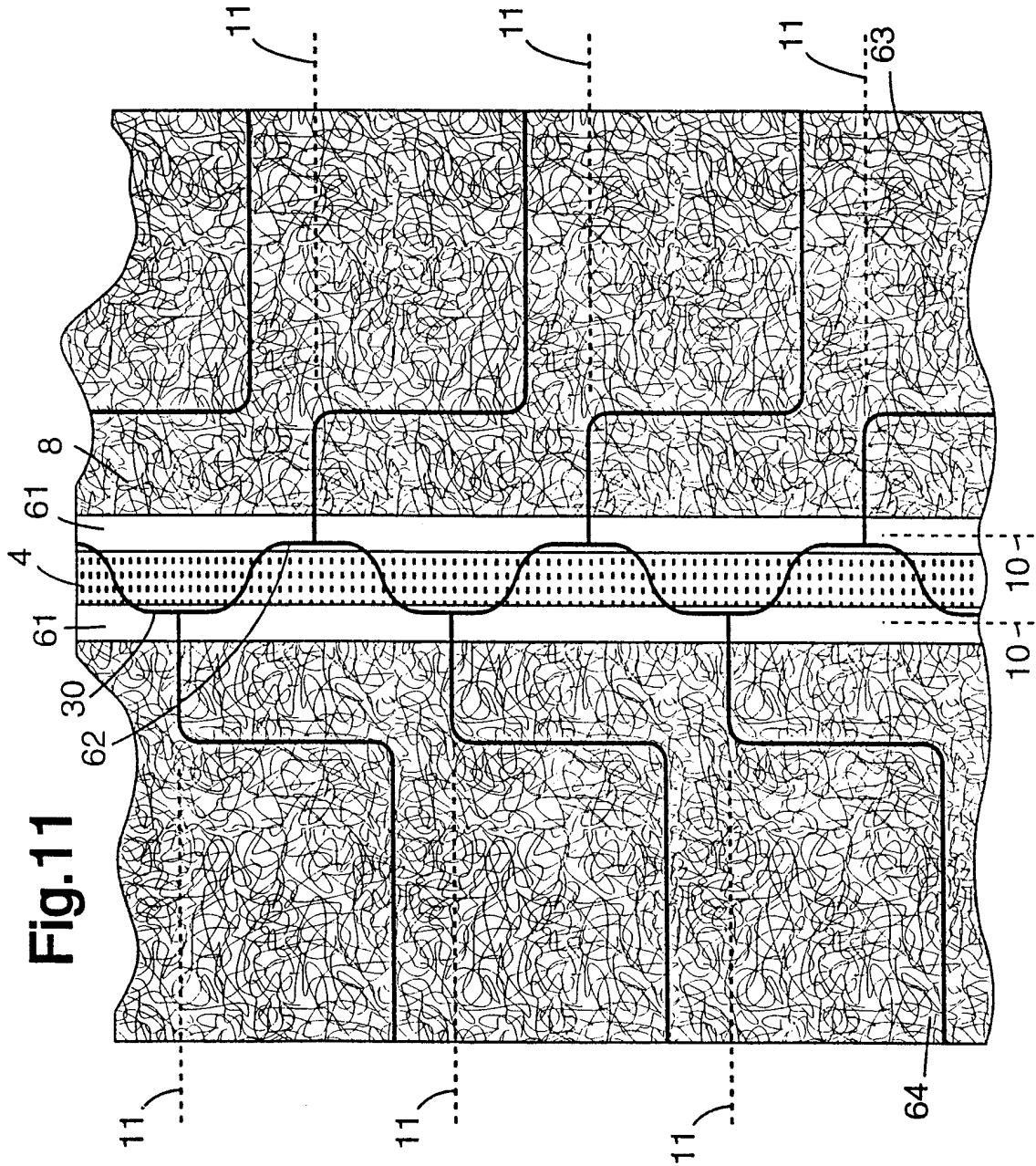

Fig. 11

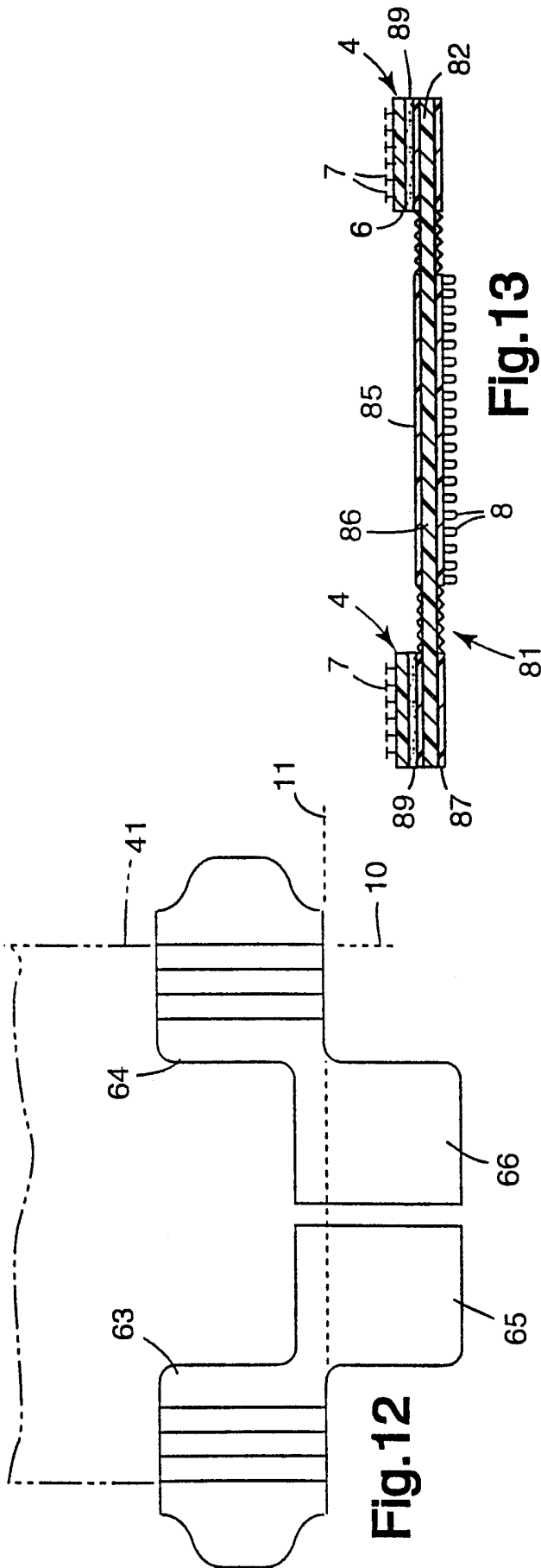

Fig. 13

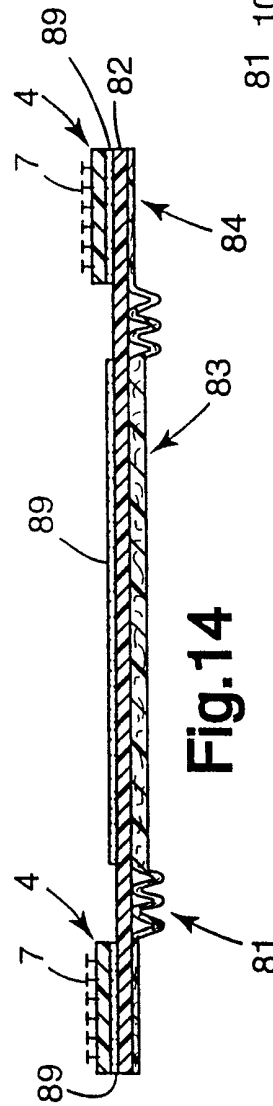

Fig. 14

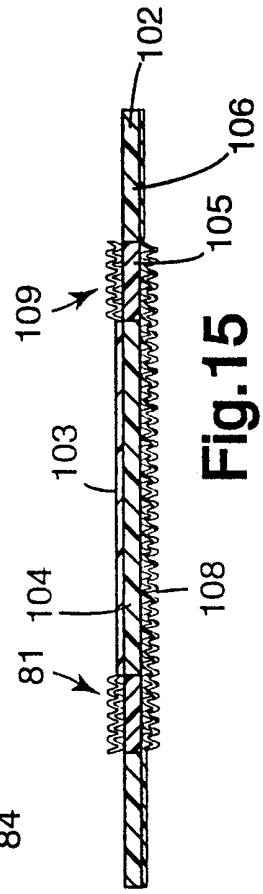

Fig. 15

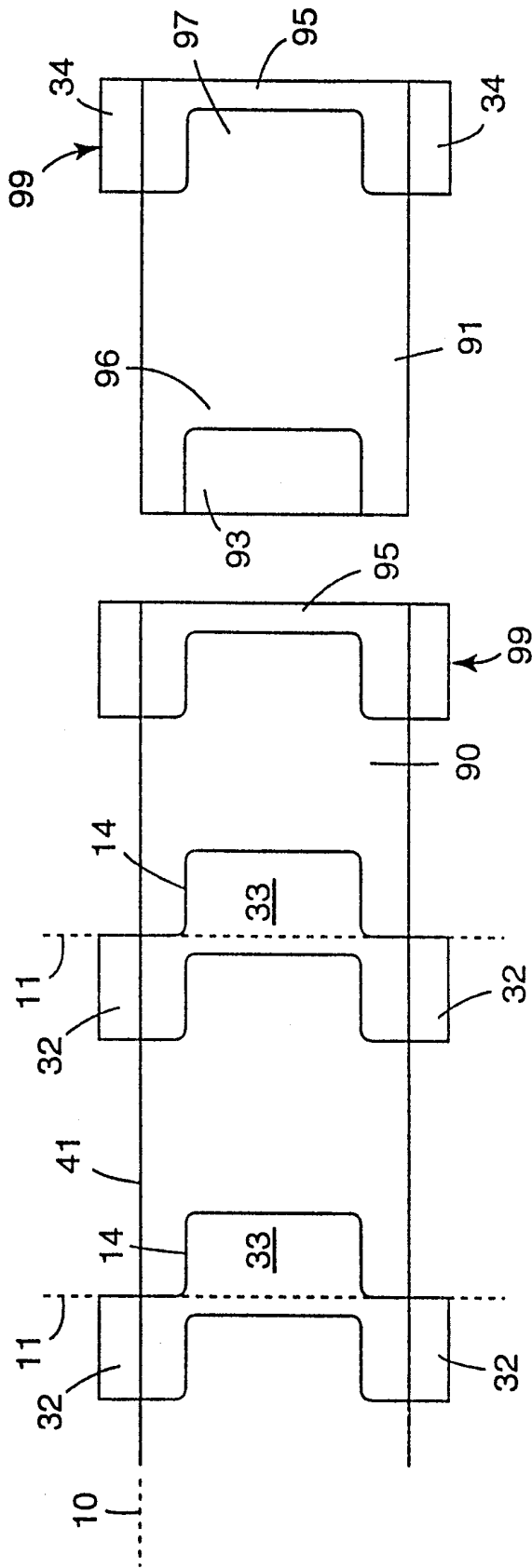
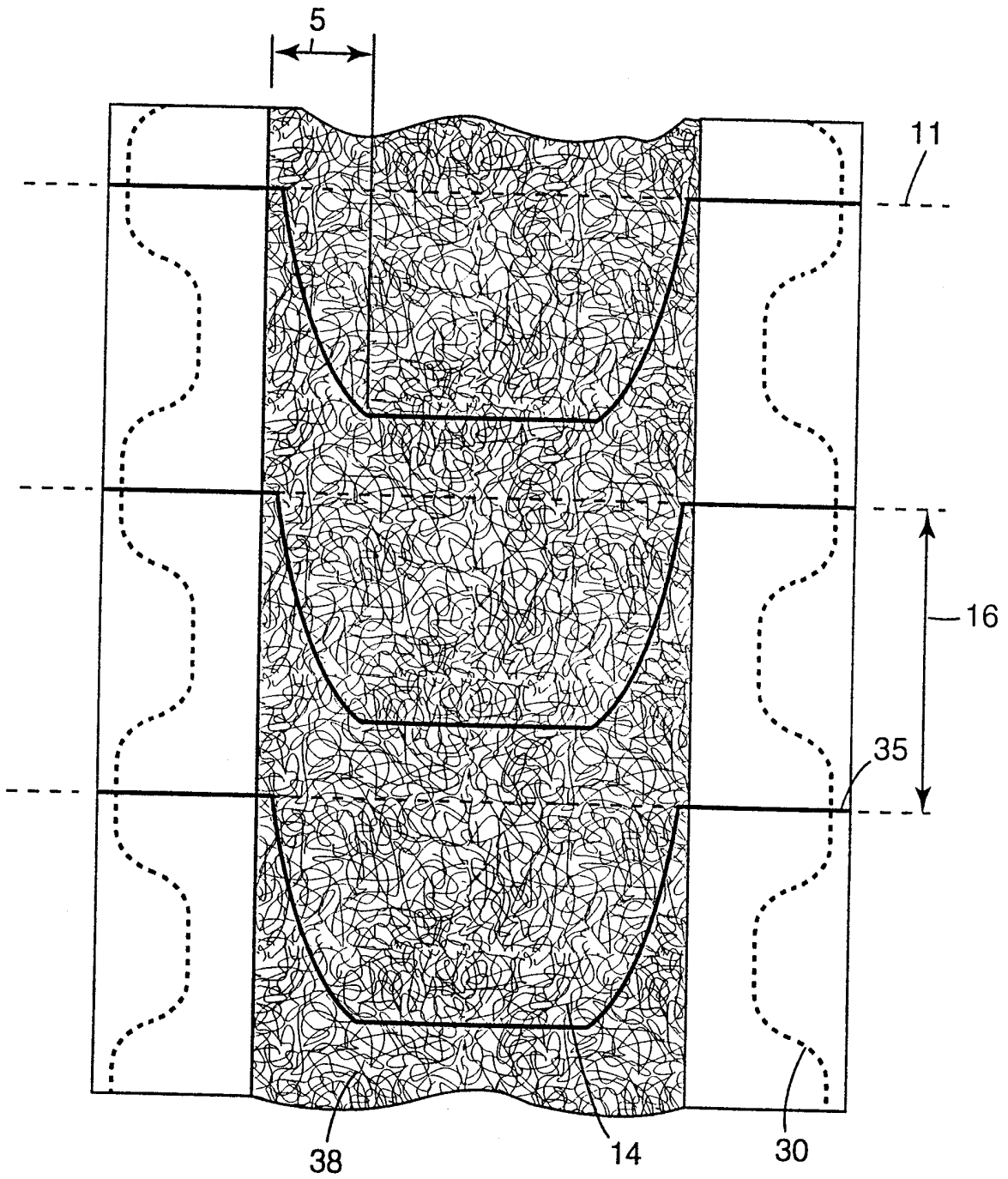

Fig.16



**Fig.17**

INTERNATIONAL SEARCH REPORT

International Application No

PCT/US 98/03501

A. CLASSIFICATION OF SUBJECT MATTER  
 IPC 6 A61F13/56 A61F13/58

According to International Patent Classification (IPC) or to both national classification and IPC

B. FIELDS SEARCHED

Minimum documentation searched (classification system followed by classification symbols)

IPC 6 A61F

Documentation searched other than minimum documentation to the extent that such documents are included in the fields searched

Electronic data base consulted during the international search (name of data base and, where practical, search terms used)

C. DOCUMENTS CONSIDERED TO BE RELEVANT

Category	Citation of document, with indication, where appropriate, of the relevant passages	Relevant to claim No.
A	GB 2 303 048 A (MOELNLYCKE AB) 12 February 1997 see claims 1-3; figures 1-13	1, 7, 8, 11, 18, 19
A	EP 0 529 681 A (PROCTER & GAMBLE) 3 March 1993 see claim 1; figures 1-9	7, 8, 11, 13-15, 18, 19
A	EP 0 388 681 A (WEYERHAEUSER CO) 26 September 1990 see page 13, line 55 - page 14, line 16	7

Further documents are listed in the continuation of box C.

Patent family members are listed in annex.

Special categories of cited documents:

- "A" document defining the general state of the art which is not considered to be of particular relevance
- "E" earlier document but published on or after the international filing date
- "L" document which may throw doubts on priority claim(s) or which is cited to establish the publication date of another citation or other special reason (as specified)
- "O" document referring to an oral disclosure, use, exhibition or other means
- "P" document published prior to the international filing date but later than the priority date claimed

- "T" later document published after the international filing date or priority date and not in conflict with the application but cited to understand the principle or theory underlying the invention
- "X" document of particular relevance; the claimed invention cannot be considered novel or cannot be considered to involve an inventive step when the document is taken alone
- "Y" document of particular relevance; the claimed invention cannot be considered to involve an inventive step when the document is combined with one or more other such documents, such combination being obvious to a person skilled in the art.
- "&" document member of the same patent family

Date of the actual completion of the international search

5 August 1998

Date of mailing of the international search report

12/08/1998

Name and mailing address of the ISA

European Patent Office, P.B. 5818 Patentlaan 2  
 NL - 2280 HV Rijswijk  
 Tel. (+31-70) 340-2040, Tx. 31 651 epo nl,  
 Fax: (+31-70) 340-3016

Authorized officer

Calamida, G

# INTERNATIONAL SEARCH REPORT

Information on patent family members

International Application No

PCT/US 98/03501

Patent document cited in search report	A	Publication date	Patent family member(s)	Publication date
GB 2303048	A	12-02-1997	SE 504649 C	24-03-1997
			AU 6373196 A	10-02-1997
			EP 0840585 A	13-05-1998
			PL 324419 A	25-05-1998
			SE 9502494 A	08-01-1997
			WO 9702799 A	30-01-1997
			<hr style="border-top: 1px dashed black;"/>	
EP 0529681	A	03-03-1993	US 4963140 A	16-10-1990
			US 4869724 A	26-09-1989
			AU 629194 B	01-10-1992
			AU 2763988 A	05-07-1990
			DE 3881179 A	24-06-1993
			DE 3881179 T	28-10-1993
			EP 0321234 A	21-06-1989
			GR 3007914 T	31-08-1993
			JP 9168564 A	30-06-1997
			JP 2004372 A	09-01-1990
			JP 2608126 B	07-05-1997
			US 5279604 A	18-01-1994
			CA 1332096 A	27-09-1994
			<hr style="border-top: 1px dashed black;"/>	
EP 0388681	A	26-09-1990	AT 116839 T	15-01-1995
			CA 2011596 A	24-09-1990
			DE 69015850 D	23-02-1995
			DE 69015850 T	24-05-1995
			ES 2069615 T	16-05-1995
			JP 2297363 A	07-12-1990
			US 5342344 A	30-08-1994
			US 5545159 A	13-08-1996
			US 5269776 A	14-12-1993
			US 5324279 A	28-06-1994