



- (51) International Patent Classification:

A24B 15/18 (2006.01)	A61M 16/18 (2006.01)
A24D 1/00 (2006.01)	C23C 18/02 (2006.01)
A24F 47/00 (2006.01)	F02M 15/04 (2006.01)
A61M 16/14 (2006.01)	
- (21) International Application Number: PCT/US20 16/032693
- (22) International Filing Date: 16 May 2016 (16.05.2016)
- (25) Filing Language: English
- (26) Publication Language: English
- (30) Priority Data:
62/162,624 15 May 2015 (15.05.2015) US
- (72) Inventor; and
- (71) Applicant : CAMERON, John [US/US]; 11345 Ventura Blvd., Studio City, CA 91604 (US).
- (74) Agents: BROWN, Charley F. et al; Ballard Spahr LLP, 999 Peachtree Street, Suite 1000, Atlanta, GA 30309 (US).

- (81) Designated States (unless otherwise indicated, for every kind of national protection available): AE, AG, AL, AM, AO, AT, AU, AZ, BA, BB, BG, BH, BN, BR, BW, BY, BZ, CA, CH, CL, CN, CO, CR, CU, CZ, DE, DK, DM, DO, DZ, EC, EE, EG, ES, FI, GB, GD, GE, GH, GM, GT, HN, HR, HU, ID, IL, ES, IR, IS, JP, KE, KG, KN, KP, KR, KZ, LA, LC, LK, LR, LS, LU, LY, MA, MD, ME, MG, MK, MN, MW, MX, MY, MZ, NA, NG, NI, NO, NZ, OM, PA, PE, PG, PH, PL, PT, QA, RO, RS, RU, RW, SA, SC, SD, SE, SG, SK, SL, SM, ST, SV, SY, TH, TJ, TM, TN, TR, TT, TZ, UA, UG, US, UZ, VC, VN, ZA, ZM, ZW.
- (84) Designated States (unless otherwise indicated, for every kind of regional protection available): ARIPO (BW, GH, GM, KE, LR, LS, MW, MZ, NA, RW, SD, SL, ST, SZ, TZ, UG, ZM, ZW), Eurasian (AM, AZ, BY, KG, KZ, RU, TJ, TM), European (AL, AT, BE, BG, CH, CY, CZ, DE, DK, EE, ES, FI, FR, GB, GR, HR, HU, IE, IS, IT, LT, LU, LV, MC, MK, MT, NL, NO, PL, PT, RO, RS, SE, SI, SK, SM, TR), OAPI (BF, BJ, CF, CG, CI, CM, GA, GN, GQ, GW, KM, ML, MR, NE, SN, TD, TG).

[Continued on nextpage]

(54) Title: HYBRID VAPOR DELIVERY SYSTEM UTILIZING NEBULIZED AND NON-NEBULIZED ELEMENTS

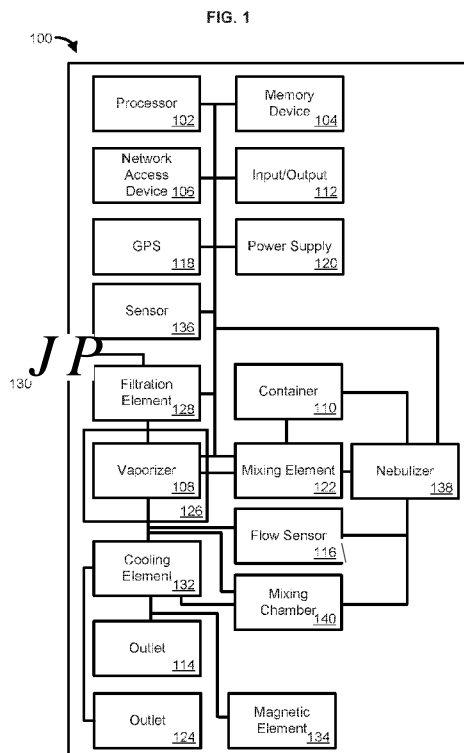

(57) Abstract: An electronic vapor device is disclosed comprising a vapor outlet, a first container for storing a vaporizable material, a second container for storing a non-vaporizable material, a vaporizer component coupled to the first container configured for vaporizing the vaporizable material at a vaporization rate to generate a first vapor and for providing the first vapor to the vapor outlet, and a nebulizer component coupled to the second container configured for nebulizing the non-vaporizable material at a nebulization rate to generate a second vapor and for providing the second vapor to the vapor outlet.

WO 2016/187115 A1

Published:

— with international search report (Art. 21(3))

HYBRID VAPOR DELIVERY SYSTEM UTILIZING NEBULIZED AND NON-NEBULIZED ELEMENTS

CROSS REFERENCE TO RELATED PATENT APPLICATION

[0001] This application claims priority to U.S. Provisional Application No. 62/162,624 filed May 15, 2015, incorporated herein by reference in its entirety.

BACKGROUND

[0002] Various types of vaporizers for medical treatment have been known in the art for many years. In general, such vaporizers are characterized by heating a solid to a smoldering point, vaporizing a liquid by heat, or nebulizing a liquid by heat and/or by expansion through a nozzle. Such devices are designed to release aromatic materials in the solid or liquid while avoiding high temperatures of combustion and associated formation of tars, carbon monoxide, or other harmful byproducts. Preferably, the device releases a very fine mist with a mouth feel similar to smoke, under suction. Thus, a vaporizing device can be made to mimic traditional smoking articles such as cigarettes, cigars, pipes and hookahs in certain aspects, while avoiding significant adverse health effects of traditional tobacco or other herbal consumption.

[0003] While various designs are long known, it is only relatively recently that technology has improved and markets have developed to the point to make mass-marketing of personal vaporizers practical. A large variety of rechargeable and disposal products have become popular. In both types of popular products on the market today, control of the vaporization products is generally limited to managing the supply of a vaporizing fluid at the point of production or recharging.

[0004] Nevertheless, there are no personal vaporizers capable of interchangeably providing one or both of vaporized and non-vaporized materials in an inhalable form.

[0005] It would be desirable, therefore, to develop new technologies for controlling operation of a vaporizing or nebulizing device, that overcomes these and other limitations of the prior art, and enhances the utility of such devices.

SUMMARY

[0006] It is to be understood that both the following general description and the following detailed description are exemplary and explanatory only and are not restrictive. An electronic vapor device is disclosed comprising a vapor outlet, a first container for storing a vaporizable material, a second container for storing a non-vaporizable material, a vaporizer component coupled to the first container configured for vaporizing the

vaporizable material at a vaporization rate to generate a first vapor and for providing the first vapor to the vapor outlet, and a nebulizer component coupled to the second container configured for nebulizing the non-vaporizable material at a nebulization rate to generate a second vapor and for providing the second vapor to the vapor outlet.

[0007] In an aspect, a method is disclosed comprising determining a vaporization rate and a nebulization rate, vaporizing a vaporizable material based on the vaporization rate to create a first vapor, nebulizing a non-vaporizable material based on the nebulization rate to create a second vapor, mixing the first vapor and the second vapor to create a mixed vapor, and expelling the mixed vapor through an exhaust port.

[0008] Additional advantages will be set forth in part in the description which follows or can be learned by practice. The advantages will be realized and attained by means of the elements and combinations particularly pointed out in the appended claims. It is to be understood that both the foregoing general description and the following detailed description are exemplary and explanatory only and are not restrictive.

BRIEF DESCRIPTION OF THE DRAWINGS

[0009] The features, nature, and advantages of the present disclosure will become more apparent from the detailed description set forth below when taken in conjunction with the drawings, in which like reference characters are used to identify like elements correspondingly throughout the specification and drawings.

Figure 1 illustrates a block diagram of an exemplary electronic vapor device;

Figure 2 illustrates an exemplary vaporizer;

Figure 3 illustrates an exemplary vaporizer configured for vaporizing a mixture of vaporizable material;

Figure 4 illustrates an exemplary vaporizer device configured for smooth vapor delivery;

Figure 5 illustrates another exemplary vaporizer configured for smooth vapor delivery;

Figure 6 illustrates another exemplary vaporizer configured for smooth vapor delivery;

Figure 7 illustrates another exemplary vaporizer configured for smooth vapor delivery;

Figure 8 illustrates an exemplary vaporizer configured for filtering air;

Figure 9 illustrates an interface of an exemplary electronic vapor device;

Figure 10 illustrates another interface of an exemplary electronic vapor device;

Figure 11 illustrates several interfaces of an exemplary electronic vapor device;

Figure 12 illustrates an exemplary operating environment;

Figure 13 illustrates another exemplary operating environment;

Figure 14 illustrates an example vaporizer apparatus;

Figure 15 illustrates an example vaporizer apparatus and operating environment;

Figure 16 illustrates example vaporizer apparatus;

Figure 17 illustrates an exemplary method;

Figure 18 illustrates an exemplary method;

Figure 19 illustrates an exemplary method; and

Figure 20 illustrates an exemplary method.

DETAILED DESCRIPTION

[0010] Before the present methods and systems are disclosed and described, it is to be understood that the methods and systems are not limited to specific methods, specific components, or to particular implementations. It is also to be understood that the terminology used herein is for the purpose of describing particular embodiments only and is not intended to be limiting.

[0011] As used in the specification and the appended claims, the singular forms "a," "an," and "the" include plural referents unless the context clearly dictates otherwise. Ranges can be expressed herein as from "about" one particular value, and/or to "about" another particular value. When such a range is expressed, another embodiment includes- from the one particular value and/or to the other particular value. Similarly, when values are expressed as approximations, by use of the antecedent "about," it will be understood that the particular value forms another embodiment. It will be further understood that the endpoints of each of the ranges are significant both in relation to the other endpoint, and independently of the other endpoint.

[0012] "Optional" or "optionally" means that the subsequently described event or circumstance may or may not occur, and that the description includes instances where said event or circumstance occurs and instances where it does not.

[0013] Throughout the description and claims of this specification, the word "comprise" and variations of the word, such as "comprising" and "comprises," means "including but not limited to," and is not intended to exclude, for example, other components, integers or steps. "Exemplary" means "an example of" and is not intended to convey an indication of a preferred or ideal embodiment. "Such as" is not used in a restrictive sense, but for explanatory purposes.

[0014] Disclosed are components that can be used to perform the disclosed methods and systems. These and other components are disclosed herein, and it is understood that when combinations, subsets, interactions, groups, etc. of these components are disclosed that

while specific reference of each various individual and collective combinations and permutation of these may not be explicitly disclosed, each is specifically contemplated and described herein, for all methods and systems. This applies to all aspects of this application including, but not limited to, steps in disclosed methods. Thus, if there are a variety of additional steps that can be performed it is understood that each of these additional steps can be performed with any specific embodiment or combination of embodiments of the disclosed methods.

[0015] The present methods and systems can be understood more readily by reference to the following detailed description of preferred embodiments and the examples included therein and to the Figures and their previous and following description.

[0016] As will be appreciated by one skilled in the art, the methods and systems may take the form of an entirely hardware embodiment, an entirely software embodiment, or an embodiment combining software and hardware aspects. Furthermore, the methods and systems may take the form of a computer program product on a computer-readable storage medium having computer-readable program instructions (e.g., computer software) embodied in the storage medium. More particularly, the present methods and systems may take the form of web-implemented computer software. Any suitable computer-readable storage medium can be utilized including hard disks, CD-ROMs, optical storage devices, or magnetic storage devices.

[0017] Embodiments of the methods and systems are described below with reference to block diagrams and flowchart illustrations of methods, systems, apparatuses and computer program products. It will be understood that each block of the block diagrams and flowchart illustrations, and combinations of blocks in the block diagrams and flowchart illustrations, respectively, can be implemented by computer program instructions. These computer program instructions can be loaded onto a general purpose computer, special purpose computer, or other programmable data processing apparatus to produce a machine, such that the instructions which execute on the computer or other programmable data processing apparatus create a means for implementing the functions specified in the flowchart block or blocks.

[0018] These computer program instructions may also be stored in a computer-readable memory that can direct a computer or other programmable data processing apparatus to function in a particular manner, such that the instructions stored in the computer-readable memory produce an article of manufacture including computer-readable instructions for implementing the function specified in the flowchart block or blocks. The computer

program instructions may also be loaded onto a computer or other programmable data processing apparatus to cause a series of operational steps to be performed on the computer or other programmable apparatus to produce a computer-implemented process such that the instructions that execute on the computer or other programmable apparatus provide steps for implementing the functions specified in the flowchart block or blocks.

[0019] Accordingly, blocks of the block diagrams and flowchart illustrations support combinations of means for performing the specified functions, combinations of steps for performing the specified functions and program instruction means for performing the specified functions. It will also be understood that each block of the block diagrams and flowchart illustrations, and combinations of blocks in the block diagrams and flowchart illustrations, can be implemented by special purpose hardware-based computer systems that perform the specified functions or steps, or combinations of special purpose hardware and computer instructions.

[0020] Various aspects are now described with reference to the drawings. In the following description, for purposes of explanation, numerous specific details are set forth in order to provide a thorough understanding of one or more aspects. It can be evident, however, that the various aspects can be practiced without these specific details. In other instances, well-known structures and devices are shown in block diagram form in order to facilitate describing these aspects.

[0021] While embodiments of the disclosure are directed to vaporizing devices, it should be appreciated that aspects of the technology can be adapted by one of ordinary skill to nebulizing devices designed to produce an inhalable mist or aerosol.

[0022] The present disclosure relates to controlling operation of a hybrid vapor delivery apparatus configured to provide nebulized and non-nebulized materials in an inhalable form.

[0023] There are currently no robust systems that are capable of interchangeably delivering one or both of nebulized and non-nebulized materials in an inhalable form.

[0024] In an aspect of the disclosure, a vapor device is coupled to and may work cooperatively ("symbiotically") with an electronic (e.g., wireless) communication device, enabling the convenient use of one or more vapor device via the electronic communication device to enhance electronic and computing resources available to the vapor device(s), including but not limited to electrical power, communications bandwidth, data, applications, processing bandwidth, memory, graphics processing, sensor capability, communications technology (e.g., access to Wifi or other network), user interface display,

light, camera, microphone, or other ancillary equipment. Conversely, the vapor device(s) via the coupling can enhance the resources available to the communication device, including but not limited to sensor capability, data, applications, sensory output modes, and communications technology. Other conveniences include the simultaneous use of both devices and the data gathering and dissemination ability of the electronic communication device to capture and share incoming and outgoing data and other resources between the electronic vaporization device and the vapor device. Sharing of application resources may include, for example, messaging and chat functions, access control functions, interface functions, and e-commerce functions, for example shopping, purchase and payment functions. Data sharing may include, for example, exchange of registrations, encryptions, user data, messaging third party communications, usage information, biographical information, recommendations, third party information, billing and verification, charging, system gauges and efficiency settings, alerts, visual information & functions, audio information.

[0025] The vapor device(s) may operate independently of the communication device, with limited resource sharing such as data and power. In an alternative, or in addition, the vaping device(s) may be utilized in unison. For example, a vapor device may be configured to operate as a slave or terminal of the communication device, or vice versa. In an alternative, the vapor device and the communication device may be configured to operate as peer devices. In unison, the devices may exchange information and the data from one device may be utilized and synthesized from the other including not only data available on the instant devices but also data available from sources external to the instant devices via data ports or wireless communication systems to enable a robust set of communication and interface potentialities. In summary the disclosure describes systems, methods and devices for physically and/or communicatively linking an electronic vapor device with an electronic communication device, wherein the devices function symbiotically or cooperatively with each other.

[0026] Various automatic registration systems having monitoring modules may be adapted to communicate between the vapor device/communication device symbiotic pair and remote sites. Devices at one or more locations may interface with the monitoring modules. Advantageously, the vaping device or the symbiotic pair devices do not need to be registered. Instead, their participation with local or remote monitoring may be transient, without disabling use of monitoring data. For example, monitoring data may be

used to generate recommendations during use, and after use may be automatically purged from the system to maintain device anonymity and protect the privacy of the user.

[0027] The vaping device(s) and the electronic communication system may be coupled wirelessly or using a wired connection, in either case with or without a physical coupling other than for communication in the case of a wired coupling. If a physical coupling is used, each vaping device devices may be may be coupled to the communication devices by at least one of a magnet, a clip, a physical weld, a screw in component a male/female connector, a zipper, Velcro, a third party agent, snap in lock, a key lock, a combination lock, a spiral brace, a spiral lock, a flexible screw or tier system which locks and unlocks at multiple tiers, an oscillating or telescopic click, twist, slide, grasp, pull push, fluid lock, pressure lock, temporary adhesive, permanent adhesive, brace, tooth locking mechanism. A locking mechanism may be controlled by at least one of voice profile module, password or passcode module, physical key, fingerprint scanner, iris identification scanner, third party device authorization, or other biometric data, for locking or unlocking. A physical coupling may be designed so that the look and feel of the symbiotic devices are one of continuous, integrated device, or non-continuous as separate, independent devices.

[0028] In other aspects, an electronic assembly (e.g., symbiotic pair) provides a material in an inhalable form while transmitting and receiving data between the assembly and other electronic devices. The assembly or pair may include a first device coupled to a second device, the first device adapted to vaporize or nebulize a substance, the second device providing power to the first device, and the second device adapted to monitor and control the first device.

[0029] In related aspects the second device may be adapted to transmit usage information regarding the first device to a central server. In addition, the second device may be adapted to receive instructions regarding the first device from the central server. For example, the instructions may be based on the usage information. The first device may be an electronic vaporizing device or an electronic nebulizing device, and the second device may be a smart phone, smart watch, or palm/notepad computer. The first device may be adapted to provide power to the second device, or vice-versa.

[0030] In an aspect, a method of transmitting and receiving data between an electronic assembly and other electronic devices may include monitoring, by a processor, usage of a first device; and transmitting, by a transmitter, usage information regarding the usage to a central server. The method may further include coupling the first device to a second

device, and controlling, by the processor, the first device based on the usage of the first device. In related aspects the transmitter may receive instructions from the central server, which instructions may be based on the usage information and/or other data.

[0031] **FIG. 1** is a block diagram of an exemplary electronic vapor device **100** as described herein. The electronic vapor device **100** can be, for example, an e-cigarette, an e-cigar, an electronic vapor device, a hybrid electronic communication handset coupled/integrated vapor device, a robotic vapor device, a modified vapor device "mod," a micro-sized electronic vapor device, a robotic vapor device, and the like. The vapor device **100** can comprise any suitable housing for enclosing and protecting the various components disclosed herein. The vapor device **100** can comprise a processor **102**. The processor **102** can be, or can comprise, any suitable microprocessor or microcontroller, for example, a low-power application-specific controller (ASIC) and/or a field programmable gate array (FPGA) designed or programmed specifically for the task of controlling a device as described herein, or a general purpose central processing unit (CPU), for example, one based on 80 x 86 architecture as designed by Intel™ or AMD™, or a system-on-a-chip as designed by ARM™. The processor **102** can be coupled (e.g., communicatively, operatively, etc. ...) to auxiliary devices or modules of the vapor device **100** using a bus or other coupling. The vapor device **100** can comprise a power supply **110**. The power supply **110** can comprise one or more batteries and/or other power storage device (e.g., capacitor) and/or a port for connecting to an external power supply. For example, an external power supply can supply power to the vapor device **100** and a battery can store at least a portion of the supplied power. The one or more batteries can be rechargeable. The one or more batteries can comprise a lithium-ion battery (including thin film lithium ion batteries), a lithium ion polymer battery, a nickel-cadmium battery, a nickel metal hydride battery, a lead-acid battery, combinations thereof, and the like. In an aspect, the power supply **110** can receive power via a power coupling to a case, wherein the vapor device **100** is stored in the case.

[0032] The vapor device **100** can comprise a memory device **104** coupled to the processor **102**. The memory device **104** can comprise a random access memory (RAM) configured for storing program instructions and data for execution or processing by the processor **102** during control of the vapor device **100**. When the vapor device **100** is powered off or in an inactive state, program instructions and data can be stored in a long-term memory, for example, a non-volatile magnetic optical, or electronic memory storage device (not shown). Either or both of the RAM or the long-term memory can comprise a

non-transitory computer-readable medium storing program instructions that, when executed by the processor **102**, cause the vapor device **100** to perform all or part of one or more methods and/or operations described herein. Program instructions can be written in any suitable high-level language, for example, C, C++, C# or the Java™, and compiled to produce machine-language code for execution by the processor **102**.

[0033] In an aspect, the vapor device **100** can comprise a network access device **106** allowing the vapor device **100** to be coupled to one or more ancillary devices (not shown) such as via an access point (not shown) of a wireless telephone network, local area network, or other coupling to a wide area network, for example, the Internet. In that regard, the processor **102** can be configured to share data with the one or more ancillary devices via the network access device **106**. The shared data can comprise, for example, usage data and/or operational data of the vapor device **100**, a status of the vapor device **100**, a status and/or operating condition of one or more the components of the vapor device **100**, text to be used in a message, a product order, payment information, and/or any other data. Similarly, the processor **102** can be configured to receive control instructions from the one or more ancillary devices via the network access device **106**. For example, a configuration of the vapor device **100**, an operation of the vapor device **100**, and/or other settings of the vapor device **100**, can be controlled by the one or more ancillary devices via the network access device **106**. For example, an ancillary device can comprise a server that can provide various services and another ancillary device can comprise a smartphone for controlling operation of the vapor device **100**. In some aspects, the smartphone or another ancillary device can be used as a primary input/output of the vapor device **100** such that data is received by the vapor device **100** from the server, transmitted to the smartphone, and output on a display of the smartphone. In an aspect, data transmitted to the ancillary device can comprise a mixture of vaporizable material and/or instructions to release vapor. For example, the vapor device **100** can be configured to determine a need for the release of vapor into the atmosphere. The vapor device **100** can provide instructions via the network access device **106** to an ancillary device (e.g., another vapor device) to release vapor into the atmosphere.

[0034] In an aspect, data can be shared anonymously. The data can be shared over a transient data session with an ancillary device. The transient data session can comprise a session limit. The session limit can be based on one or more of a number of puffs, a time limit, and a total quantity of vaporizable material. The data can comprise usage data and/or a usage profile.

[0035] In an aspect, the vapor device **100** can also comprise an input/output device **112** coupled to one or more of the processor **102**, a vaporizer **108**, the network access device **106**, and/or any other electronic component of the vapor device **100**. Input can be received from a user or another device and/or output can be provided to a user or another device via the input/output device **112**. The input/output device **112** can comprise any combinations of input and/or output devices such as buttons, knobs, keyboards, touchscreens, displays, light-emitting elements, a speaker, and/or the like. In an aspect, the input/output device **112** can comprise an interface port (not shown) such as a wired interface, for example a serial port, a Universal Serial Bus (USB) port, an Ethernet port, or other suitable wired connection. The input/output device **112** can comprise a wireless interface (not shown), for example a transceiver using any suitable wireless protocol, for example WiFi (IEEE **802.11**), Bluetooth®, infrared, or other wireless standard. For example, the input/output device **112** can communicate with a smartphone via Bluetooth® such that the inputs and outputs of the smartphone can be used by the user to interface with the vapor device **100**. In an aspect, the input/output device **112** can comprise a user interface. The user interface user interface can comprise at least one of lighted signal lights, gauges, boxes, forms, check marks, avatars, visual images, graphic designs, lists, active calibrations or calculations, 2D interactive fractal designs, 3D fractal designs, 2D and/or 3D representations of vapor devices and other interface system functions.

[0036] In an aspect, the input/output device **112** can be coupled to an adaptor device to receive power and/or send/receive data signals from an electronic device. For example, the input/output device **112** can be configured to receive power from the adaptor device and provide the power to the power supply **120** to recharge one or more batteries. The input/output device **112** can exchange data signals received from the adaptor device with the processor **102** to cause the processor to execute one or more functions.

[0037] In an aspect, the input/output device **112** can comprise a touchscreen interface and/or a biometric interface. For example, the input/output device **112** can include controls that allow the user to interact with and input information and commands to the vapor device **100**. For example, with respect to the embodiments described herein, the input/output device **112** can comprise a touch screen display. The input/output device **112** can be configured to provide the content of the exemplary screen shots shown herein, which are presented to the user via the functionality of a display. User inputs to the touch screen display are processed by, for example, the input/output device **112** and/or the

processor **102**. The input/output device **112** can also be configured to process new content and communications to the system **100**. The touch screen display can provide controls and menu selections, and process commands and requests. Application and content objects can be provided by the touch screen display. The input/output device **112** and/or the processor **102** can receive and interpret commands and other inputs, interface with the other components of the vapor device **100** as required. In an aspect, the touch screen display can enable a user to lock, unlock, or partially unlock or lock, the vapor device **100**. The vapor device **100** can be transitioned from an idle and locked state into an open state by, for example, moving or dragging an icon on the screen of the vapor device **100**, entering in a password/passcode, and the like. The input/output device **112** can thus display information to a user such as a puff count, an amount of vaporizable material remaining in the container **110**, battery remaining, signal strength, combinations thereof, and the like.

[0038] In an aspect, the input/output device **112** can comprise an audio user interface. A microphone can be configured to receive audio signals and relay the audio signals to the input/output device **112**. The audio user interface can be any interface that is responsive to voice or other audio commands. The audio user interface can be configured to cause an action, activate a function, etc. by the vapor device **100** (or another device) based on a received voice (or other audio) command. The audio user interface can be deployed directly on the vapor device **100** and/or via other electronic devices (e.g., electronic communication devices such as a smartphone, a smart watch, a tablet, a laptop, a dedicated audio user interface device, and the like). The audio user interface can be used to control the functionality of the vapor device **100**. Such functionality can comprise, but is not limited to, custom mixing of vaporizable material (e.g., eLiquids) and/or ordering custom made eLiquid combinations via an eCommerce service (e.g., specifications of a user's custom flavor mix can be transmitted to an eCommerce service, so that an eLiquid provider can mix a custom eLiquid cartridge for the user). The user can then reorder the custom flavor mix anytime or even send it to friends as a present, all via the audio user interface. The user can also send via voice command a mixing recipe to other users. The other users can utilize the mixing recipe (e.g., via an electronic vapor device having multiple chambers for eLiquid) to sample the same mix via an auto-order to the other users' devices to create the received mixing recipe. A custom mix can be given a title by a user and/or can be defined by parts (e.g., one part liquid A and two parts liquid B). The audio user interface can also be utilized to create and send a custom message to other

users, to join eVapor clubs, to receive eVapor chart information, and to conduct a wide range of social networking, location services and eCommerce activities. The audio user interface can be secured via a password (e.g., audio password) which features at least one of tone recognition, other voice quality recognition and, in one aspect, can utilize at least one special cadence as part of the audio password.

[0039] The input/output device **112** can be configured to interface with other devices, for example, exercise equipment, computing equipment, communications devices and/or other vapor devices, for example, via a physical or wireless connection. The input/output device **112** can thus exchange data with the other equipment. A user may sync their vapor device **100** to other devices, via programming attributes such as mutual dynamic link library (DLL) 'hooks'. This enables a smooth exchange of data between devices, as can a web interface between devices. The input/output device **112** can be used to upload one or more profiles to the other devices. Using exercise equipment as an example, the one or more profiles can comprise data such as workout routine data (e.g., timing, distance, settings, heart rate, etc ..) and vaping data (e.g., eLiquid mixture recipes, supplements, vaping timing, etc ..). Data from usage of previous exercise sessions can be archived and shared with new electronic vapor devices and/or new exercise equipment so that history and preferences may remain continuous and provide for simplified device settings, default settings, and recommended settings based upon the synthesis of current and archival data.

[0040] In an aspect, the vapor device **100** can comprise a vaporizer **108**. In an aspect, the vapor device **100** can comprise a plurality of vaporizers **108**. The vaporizer **108** can be coupled to one or more containers **110**. In an aspect, the plurality of vaporizers **108** can each be coupled to a separate container. Each of the one or more containers **110** can be configured to hold one or more vaporizable or non-vaporizable materials. The vaporizer **108** can receive the one or more vaporizable or non-vaporizable materials from the one or more containers **110** and heat the one or more vaporizable or non-vaporizable materials until the one or more vaporizable or non-vaporizable materials achieve a vapor state. In various embodiments, instead of heating the one or more vaporizable or non-vaporizable materials, the vaporizer **108** can nebulize or otherwise cause the one or more vaporizable or non-vaporizable materials in the one or more containers **110** to reduce in size into particulates. In various embodiments, the one or more containers **110** can comprise a compressed liquid that can be released to the vaporizer **108** via a valve or another mechanism. In various embodiments, the one or more containers **110** can comprise a wick (not shown) through which the one or more vaporizable or non-vaporizable materials is

drawn to the vaporizer 108. The one or more containers 110 can be made of any suitable structural material, such as, an organic polymer, metal, ceramic, composite, or glass material. In an aspect, the vaporizable material can comprise one or more of, a Propylene Glycol (PG) based liquid, a Vegetable Glycerin (VG) based liquid, a water based liquid, combinations thereof, and the like. In an aspect, the vaporizable material can comprise Tetrahydrocannabinol (THC), Cannabidiol (CBD), cannabitol (CBN), combinations thereof, and the like. In a further aspect, the vaporizable material can comprise an extract from *duboisia hopwoodii*.

[0041] In an aspect, the vapor device 100 can comprise a mixing element 122. The mixing element 122 can be coupled to the processor 102 to receive one or more control signals. The one or more control signals can instruct the mixing element 122 to withdraw specific amounts of fluid from the one or more containers 110. The mixing element can, in response to a control signal from the processor 102, withdraw select quantities of vaporizable material in order to create a customized mixture of different types of vaporizable material. The liquid withdrawn by the mixing element 122 can be provided to the vaporizer 108.

[0042] The vapor device 100 may include a plurality of valves, wherein a respective one of the valves is interposed between the vaporizer 108 and a corresponding one of outlet 114 and/or outlet 124 (e.g., one or more inlets of flexible tubes). Each of the valves may control a flow rate through a respective one of the flexible tubes. For example, each of the plurality of valves may include a lumen of adjustable effective diameter for controlling a rate of vapor flow there through. The assembly may include an actuator, for example a motor, configured to independently adjust respective ones of the valves under control of the processor. The actuator may include a handle or the like to permit manual valve adjustment by the user. The motor or actuator can be coupled to a uniform flange or rotating spindle coupled to the valves and configured for controlling the flow of vapor through each of the valves. Each of the valves can be adjusted so that each of the flexible tubes accommodate the same (equal) rate of vapor flow, or different rates of flow. The processor 102 can be configured to determine settings for the respective ones of the valves each based on at least one of: a selected user preference or an amount of suction applied to a corresponding one of the flexible tubes. A user preference can be determined by the processor 102 based on a user input, which can be electrical or mechanical. An electrical input can be provided, for example, by a touchscreen, keypad, switch, or potentiometer (e.g., the input/output 112). A mechanical input can be provided, for

example, by applying suction to a mouthpiece of a tube, turning a valve handle, or moving a gate piece.

[0043] The vapor device **100** may further include at least one light-emitting element positioned on or near each of the outlet **114** and/or the outlet **124** (e.g., flexible tubes) and configured to illuminate in response to suction applied to the outlet **114** and/or the outlet **124**. At least one of an intensity of illumination or a pattern of alternating between an illuminated state and a non-illuminated state can be adjusted based on an amount of suction. One or more of the at least one light-emitting element, or another light-emitting element, may illuminate based on an amount of vaporizable material available. For example, at least one of an intensity of illumination or a pattern of alternating between an illuminated state and a non-illuminated state can be adjusted based on an amount of the vaporizable material within the vapor device **100**. In some aspects, the vapor device **100** may include at least two light-emitting elements positioned on each of the outlet **114** and/or the outlet **124**. Each of the at least two light-emitting elements may include a first light-emitting element and an outer light-emitting element positioned nearer the end of the outlet **114** and/or the outlet **124** than the first light-emitting element. Illumination of the at least two light-emitting elements may indicate a direction of a flow of vapor.

[0044] In an aspect, input from the input/output device **112** can be used by the processor **102** to cause the vaporizer **108** to vaporize the one or more vaporizable or non-vaporizable materials. For example, a user can depress a button, causing the vaporizer **108** to start vaporizing the one or more vaporizable or non-vaporizable materials. A user can then draw on an outlet **114** to inhale the vapor. In various aspects, the processor **102** can control vapor production and flow to the outlet **114** based on data detected by a flow sensor **116**. For example, as a user draws on the outlet **114**, the flow sensor **116** can detect the resultant pressure and provide a signal to the processor **102**. In response, the processor **102** can cause the vaporizer **108** to begin vaporizing the one or more vaporizable or non-vaporizable materials, terminate vaporizing the one or more vaporizable or non-vaporizable materials, and/or otherwise adjust a rate of vaporization of the one or more vaporizable or non-vaporizable materials. In an aspect, the resulting vapor from the vaporizer **108** can be provided to a mixing chamber **140** to mix with mist (e.g., vapor) from a nebulizer **138**. The processor **102** can also determine a vaporization rate and/or a nebulization rate. The vaporization rate can be an amount of vaporizable material vaporized over time. The nebulization rate can be an amount of non-vaporizable material nebulized over time. In an aspect, a vaporization rate can be determined based on a

vaporizable material. In an aspect, a nebulization rate can be determined based on a non-vaporizable material. In another aspect, a vaporization rate can be determined for each of a plurality of vaporizable materials. In another aspect, a nebulization rate can be determined for each of a plurality of non-vaporizable materials.

[0045] For example, in an embodiment of the vapor device **100** comprising two different vaporizable materials, each vaporizable material can have a vaporization rate. As a result, both vaporizable materials can be vaporized at the respective vaporization rate and the resulting vapors can be combined. In another aspect, the vaporization rates can be used to determine an amount of each vaporizable material to withdraw into the mixing element **122**. The resulting mixture of vaporizable material can then be vaporized. In a further aspect, each container **110** can comprise an independent vaporizer **108** configured to vaporize vaporizable material contained in a corresponding container **110** at a vaporization rate. As a result, the different vaporizable materials can be vaporized independently, yet simultaneously or serially. Vaporization can be performed according to a vaporization rate determined for each vaporizable material.

[0046] In another example, in an embodiment of the vapor device **100** comprising two different non-vaporizable materials, each non-vaporizable material can have a nebulization rate. As a result, both non-vaporizable materials can be nebulized at the respective nebulization rate and the resulting vapors can be combined. In another aspect, the nebulization rates can be used to determine an amount of each non-vaporizable material to withdraw into the mixing element **122**. The resulting mixture of non-vaporizable material can then be nebulized. In a further aspect, each container **110** can comprise an independent nebulizer **138** configured to nebulize non-vaporizable material contained in a corresponding container **110** at a nebulization rate. As a result, the different non-vaporizable materials can be nebulized independently, yet simultaneously or serially. Nebulization can be performed according to a nebulization rate determined for each non-vaporizable material.

[0047] In another aspect, the vapor can exit the vapor device **100** through an outlet **124**. The outlet **124** differs from the outlet **114** in that the outlet **124** can be configured to distribute the vapor into the local atmosphere, rather than being inhaled by a user. In an aspect, vapor exiting the outlet **124** can be at least one of aromatic, medicinal, recreational, and/or wellness related. In an aspect, the vapor device **100** can comprise any number of outlets. In an aspect, the outlet **114** and/or the outlet **124** can comprise at least one flexible tube. For example, a lumen of the at least one flexible tube can be in fluid

communication with one or more components (e.g., a first container) of the vapor device **100** to provide vapor to a user. In more detailed aspects, the at least one flexible tube may include at least two flexible tubes. Accordingly, the vapor device **100** may further include a second container configured to receive a second vaporizable material such that a first flexible tube can receive vapor from the first vaporizable material and a second flexible tube receive vapor from the second vaporizable material. For example, the at least two flexible tubes can be in fluid communication with the first container and with second container. The vapor device **100** may include an electrical or mechanical sensor configured to sense a pressure level, and therefore suction, in an interior of the flexible tube. Application of suction may activate the vapor device **100** and cause vapor to flow.

[0048] In another aspect, the vapor device **100** can comprise a piezoelectric dispersing element. In some aspects, the piezoelectric dispersing element can be charged by a battery, and can be driven by a processor on a circuit board. The circuit board can be produced using a polyimide such as Kapton, or other suitable material. The piezoelectric dispersing element can comprise a thin metal disc which causes dispersion of the fluid fed into the dispersing element via the wick or other soaked piece of organic material through vibration. Once in contact with the piezoelectric dispersing element, the vaporizable material (e.g., fluid) can be vaporized (e.g., turned into vapor or mist) and the vapor can be dispersed via a system pump and/or a sucking action of the user. In some aspects, the piezoelectric dispersing element can cause dispersion of the vaporizable material by producing ultrasonic vibrations. An electric field applied to a piezoelectric material within the piezoelectric element can cause ultrasonic expansion and contraction of the piezoelectric material, resulting in ultrasonic vibrations to the disc. The ultrasonic vibrations can cause the vaporizable material to disperse, thus forming a vapor or mist from the vaporizable material.

[0049] In some aspects, the connection between a power supply and the piezoelectric dispersing element can be facilitated using one or more conductive coils. The conductive coils can provide an ultrasonic power input to the piezoelectric dispersing element. For example, the signal carried by the coil can have a frequency of approximately 107.8 kHz. In some aspects, the piezoelectric dispersing element can comprise a piezoelectric dispersing element that can receive the ultrasonic signal transmitted from the power supply through the coils, and can cause vaporization of the vaporizable liquid by producing ultrasonic vibrations. An ultrasonic electric field applied to a piezoelectric material within the piezoelectric element causes ultrasonic expansion and contraction of

the piezoelectric material, resulting in ultrasonic vibrations according to the frequency of the signal. The vaporizable liquid can be vibrated by the ultrasonic energy produced by the piezoelectric dispersing element, thus causing dispersal and/or atomization of the liquid. In an aspect, the vapor device **100** can be configured to permit a user to select between using a heating element of the vaporizer **108** or the piezoelectric dispersing element. In another aspect, the vapor device **100** can be configured to permit a user to utilize both a heating element of the vaporizer **108** and the piezoelectric dispersing element.

[0050] In an aspect, the vapor device **100** can comprise a nebulizer **138** may be coupled to the one or more containers **110**. For example, coupling may be via a tube, via a valve, wick, or some other structure. The coupling mechanism may operate independently of gravity, such as by capillary action or pressure drop through a valve. The nebulizer **138** can be configured to nebulize a non-vaporizable material from one or more containers **110** at a nebulization rate; in operation, the nebulizer **138** nebulizes the non-vaporizable material, producing an inhalable mist (also referred to as a vapor) or component thereof using a process distinct from the vaporizer **108**. The nebulizer **138** can comprise at least one of a vibrating mesh for nebulizing the non-vaporizable material into a mist, an atomizer for atomizing the non-vaporizable material into an aerosol, an ultrasonic nebulizer for nebulizing the non-vaporizable material into a mist, and a heating element for enhancing effectiveness of a nebulizing process. It bears repeating, however, that vaporizability and nebulizability should be assessed relative to specific input materials and defined processes. The nebulization rate may be controlled, for example, by varying an input pressure or velocity by controlling a pump speed or valve setting. At minimum, control may be provided between no power (off state) and one or more powered states. Other control mechanisms may also be suitable. The resulting mist (e.g., vapor) from the nebulizer **138** can be provided to a mixing chamber **140** to mix with vapor from the vaporizer **108**. Alternatively, the nebulizer **138** can provide mist (e.g., vapor) directly to one or more of a cooling element **132**, an outlet **114**, and/or an outlet **124**. The nebulizer **138** can receive one or more non-vaporizable materials from the one or more containers **110** and/or the mixing element **122**. The flow sensor **116** can determine a rate of flow of resultant mist (e.g., vapor), as for the vaporizer **108**.

[0051] In an aspect, the vapor device **100** can comprise a heating casing **126**. The heating casing **126** can enclose one or more of the container **110**, the vaporizer **108**, and/or the outlet **114**. In a further aspect, the heating casing **126** can enclose one or more

components that make up the container **110**, the vaporizer **108**, and/or the outlet **114**. The heating casing **126** can be made of ceramic, metal, and/or porcelain. The heating casing **126** can have varying thickness. In an aspect, the heating casing **126** can be coupled to the power supply **120** to receive power to heat the heating casing **126**. In another aspect, the heating casing **126** can be coupled to the vaporizer **108** to heat the heating casing **126**. In another aspect, the heating casing **126** can serve an insulation role.

[0052] In an aspect, the vapor device **100** can comprise a filtration element **128**. The filtration element **128** can be configured to remove (e.g., filter, purify, etc) contaminants from air entering the vapor device **100**. The filtration element **128** can optionally comprise a fan **130** to assist in delivering air to the filtration element **128**. The vapor device **100** can be configured to intake air into the filtration element **128**, filter the air, and pass the filtered air to the vaporizer **108** for use in vaporizing the one or more vaporizable or non-vaporizable materials. In another aspect, the vapor device **100** can be configured to intake air into the filtration element **128**, filter the air, and bypass the vaporizer **108** by passing the filtered air directly to the outlet **114** for inhalation by a user.

[0053] In an aspect, the filtration element **128** can comprise cotton, polymer, wool, satin, meta materials and the like. The filtration element **128** can comprise a filter material that at least one airborne particle and/or undesired gas by a mechanical mechanism, an electrical mechanism, and/or a chemical mechanism. The filter material can comprise one or more pieces of a filter fabric that can filter out one or more airborne particles and/or gasses. The filter fabric can be a woven and/or non-woven material. The filter fabric can be made from natural fibers (e.g., cotton, wool, etc.) and/or from synthetic fibers (e.g., polyester, nylon, polypropylene, etc.). The thickness of the filter fabric can be varied depending on the desired filter efficiencies and/or the region of the apparel where the filter fabric is to be used. The filter fabric can be designed to filter airborne particles and/or gasses by mechanical mechanisms (e.g., weave density), by electrical mechanisms (e.g., charged fibers, charged metals, etc.), and/or by chemical mechanisms (e.g., absorptive charcoal particles, adsorptive materials, etc.). In an aspect, the filter material can comprise electrically charged fibers such as, but not limited to, FILTRETTE by 3M. In another aspect, the filter material can comprise a high density material similar to material used for medical masks which are used by medical personnel in doctors' offices, hospitals, and the like. In an aspect, the filter material can be treated with an anti-bacterial solution and/or otherwise made from anti-bacterial materials. In another aspect, the

filtration element 128 can comprise electrostatic plates, ultraviolet light, a HEPA filter, combinations thereof, and the like.

[0054] In an aspect, the vapor device 100 can comprise a cooling element 132. The cooling element 132 can be configured to cool vapor exiting the vaporizer 108 prior to passing through the outlet 114. The cooling element 132 can cool vapor by utilizing air or space within the vapor device 100. The air used by the cooling element 132 can be either static (existing in the vapor device 100) or drawn into an intake and through the cooling element 132 and the vapor device 100. The intake can comprise various pumping, pressure, fan, or other intake systems for drawing air into the cooling element 132. In an aspect, the cooling element 132 can reside separately or can be integrated the vaporizer 108. The cooling element 132 can be a single cooled electronic element within a tube or space and/or the cooling element 132 can be configured as a series of coils or as a grid like structure. The materials for the cooling element 132 can be metal, liquid, polymer, natural substance, synthetic substance, air, or any combination thereof. The cooling element 132 can be powered by the power supply 120, by a separate battery (not shown), or other power source (not shown) including the use of excess heat energy created by the vaporizer 108 being converted to energy used for cooling by virtue of a small turbine or pressure system to convert the energy. Heat differentials between the vaporizer 108 and the cooling element 132 can also be converted to energy utilizing commonly known geothermal energy principles.

[0055] In an aspect, the vapor device 100 can comprise a magnetic element 134. For example, the magnetic element 134 can comprise an electromagnet, a ceramic magnet, a ferrite magnet, and/or the like. The magnetic element 134 can be configured to apply a magnetic field to air as it is brought into the vapor device 100, in the vaporizer 108, and/or as vapor exits the outlet 114.

[0056] The input/output device 112 can be used to select whether vapor exiting the outlet 114 should be cooled or not cooled and/or heated or not heated and/or magnetized or not magnetized. For example, a user can use the input/output device 112 to selectively cool vapor at times and not cool vapor at other times. The user can use the input/output device 112 to selectively heat vapor at times and not heat vapor at other times. The user can use the input/output device 112 to selectively magnetize vapor at times and not magnetize vapor at other times. The user can further use the input/output device 112 to select a desired smoothness, temperature, and/or range of temperatures. The user can adjust the temperature of the vapor by selecting or clicking on a clickable setting on a part of the

vapor device **100**. The user can use, for example, a graphical user interface (GUI) or a mechanical input enabled by virtue of clicking a rotational mechanism at either end of the vapor device **100**.

[0057] In an aspect, cooling control can be set within the vapor device **100** settings via the processor **102** and system software (e.g., dynamic linked libraries). The memory **104** can store settings. Suggestions and remote settings can be communicated to and/or from the vapor device **100** via the input/output device **112** and/or the network access device **106**. Cooling of the vapor can be set and calibrated between heating and cooling mechanisms to what is deemed an ideal temperature by the manufacturer of the vapor device **100** for the vaporizable material. For example, a temperature can be set such that resultant vapor delivers the coolest feeling to the average user but does not present any health risk to the user by virtue of the vapor being too cold, including the potential for rapid expansion of cooled vapor within the lungs and the damaging of tissue by vapor which has been cooled to a temperature which may cause frostbite like symptoms.

[0058] In an aspect, the vapor device **100** can be configured to receive air, smoke, vapor or other material and analyze the contents of the air, smoke, vapor or other material using one or more sensors **136** in order to at least one of analyze, classify, compare, validate, refute, and/or catalogue the same. A result of the analysis can be, for example, an identification of at least one of medical, recreational, homeopathic, olfactory elements, spices, other cooking ingredients, ingredients analysis from food products, fuel analysis, pharmaceutical analysis, genetic modification testing analysis, dating, fossil and/or relic analysis and the like. The vapor device **100** can pass utilize, for example, mass spectrometry, PH testing, genetic testing, particle and/or cellular testing, sensor based testing and other diagnostic and wellness testing either via locally available components or by transmitting data to a remote system for analysis.

[0059] In an aspect, a user can create a custom scent by using the vapor device **100** to intake air elements, where the vapor device **100** (or third-party networked device) analyzes the olfactory elements and/or biological elements within the sample and then formulates a replica scent within the vapor device **100** (or third-party networked device) that can be accessed by the user instantly, at a later date, with the ability to purchase this custom scent from a networked ecommerce portal.

[0060] In another aspect, the one or more sensors **136** can be configured to sense negative environmental conditions (e.g., adverse weather, smoke, fire, chemicals (e.g., such as CO₂ or formaldehyde), adverse pollution, and/or disease outbreaks, and the like). The one

or more sensors 136 can comprise one or more of, a biochemical/chemical sensor, a thermal sensor, a radiation sensor, a mechanical sensor, an optical sensor, a mechanical sensor, a magnetic sensor, an electrical sensor, combinations thereof and the like. The biochemical/chemical sensor can be configured to detect one or more biochemical/chemicals causing a negative environmental condition such as, but not limited to, smoke, a vapor, a gas, a liquid, a solid, an odor, combinations thereof, and/or the like. The biochemical/chemical sensor can comprise one or more of a mass spectrometer, a conducting/nonconducting regions sensor, a SAW sensor, a quartz microbalance sensor, a conductive composite sensor, a chemiresistor, a metal oxide gas sensor, an organic gas sensor, a MOSFET, a piezoelectric device, an infrared sensor, a sintered metal oxide sensor, a Pd-gate MOSFET, a metal FET structure, an electrochemical cell, a conducting polymer sensor, a catalytic gas sensor, an organic semiconducting gas sensor, a solid electrolyte gas sensors, a piezoelectric quartz crystal sensor, and/or combinations thereof.

[0061] The thermal sensor can be configured to detect temperature, heat, heat flow, entropy, heat capacity, combinations thereof, and the like. Exemplary thermal sensors include, but are not limited to, thermocouples, such as a semiconducting thermocouples, noise thermometry, thermoswitches, thermistors, metal thermoresistors, semiconducting thermoresistors, thermodiodes, thermotransistors, calorimeters, thermometers, indicators, and fiber optics.

[0062] The radiation sensor can be configured to detect gamma rays, X-rays, ultra-violet rays, visible, infrared, microwaves and radio waves. Exemplary radiation sensors include, but are not limited to, nuclear radiation microsensors, such as scintillation counters and solid state detectors, ultra-violet, visible and near infrared radiation microsensors, such as photoconductive cells, photodiodes, phototransistors, infrared radiation microsensors, such as photoconductive IR sensors and pyroelectric sensors.

[0063] The optical sensor can be configured to detect visible, near infrared, and infrared waves. The mechanical sensor can be configured to detect displacement, velocity, acceleration, force, torque, pressure, mass, flow, acoustic wavelength, and amplitude. Exemplary mechanical sensors include, but are not limited to, displacement microsensors, capacitive and inductive displacement sensors, optical displacement sensors, ultrasonic displacement sensors, pyroelectric, velocity and flow microsensors, transistor flow microsensors, acceleration microsensors, piezoresistive microaccelerometers, force, pressure and strain microsensors, and piezoelectric crystal sensors. The magnetic sensor

can be configured to detect magnetic field, flux, magnetic moment, magnetization, and magnetic permeability. The electrical sensor can be configured to detect charge, current, voltage, resistance, conductance, capacitance, inductance, dielectric permittivity, polarization and frequency.

[0064] Upon sensing a negative environmental condition, the one or more sensors **122** can provide data to the processor **102** to determine the nature of the negative environmental condition and to generate/transmit one or more alerts based on the negative environmental condition. The one or more alerts can be deployed to the vapor device **100** user's wireless device and/or synced accounts. For example, the network device access device **106** can be used to transmit the one or more alerts directly (e.g., via Bluetooth®) to a user's smartphone to provide information to the user. In another aspect, the network access device **106** can be used to transmit sensed information and/or the one or more alerts to a remote server for use in syncing one or more other devices used by the user (e.g., other vapor devices, other electronic devices (smartphones, tablets, laptops, etc.)). In another aspect, the one or more alerts can be provided to the user of the vapor device **100** via vibrations, audio, colors, and the like deployed from the mask, for example through the input/output device **112**. For example, the input/output device **112** can comprise a small vibrating motor to alert the user to one or more sensed conditions via tactile sensation. In another example, the input/output device **112** can comprise one or more LED's of various colors to provide visual information to the user. In another example, the input/output device **112** can comprise one or more speakers that can provide audio information to the user. For example, various patterns of beeps, sounds, and/or voice recordings can be utilized to provide the audio information to the user. In another example, the input/output device **112** can comprise an LCD screen/touchscreen that provides a summary and/or detailed information regarding the negative environmental condition and/or the one or more alerts.

[0065] In another aspect, upon sensing a negative environmental condition, the one or more sensors **136** can provide data to the processor **102** to determine the nature of the negative environmental condition and to provide a recommendation for mitigating and/or to actively mitigate the negative environmental condition. Mitigating the negative environmental conditions can comprise, for example, applying a filtration system, a fan, a fire suppression system, engaging a HVAC system, and/or one or more vaporizable and/or non-vaporizable materials. The processor **102** can access a database stored in the memory device **104** to make such a determination or the network device **106** can be used

to request information from a server to verify the sensor findings. In an aspect, the server can provide an analysis service to the vapor device **100**. For example, the server can analyze data sent by the vapor device **100** based on a reading from the one or more sensors **136**. The server can determine and transmit one or more recommendations to the vapor device **100** to mitigate the sensed negative environmental condition. The vapor device **100** can use the one or more recommendations to activate a filtration system, a fan, a fire suppression system engaging a HVAC system, and/or to vaporize one or more vaporizable or non-vaporizable materials to assist in countering effects from the negative environmental condition.

[0066] In an aspect, the vapor device **100** can comprise a global positioning system (GPS) unit **118**. The GPS **118** can detect a current location of the device **100**. In some aspects, a user can request access to one or more services that rely on a current location of the user. For example, the processor **102** can receive location data from the GPS **118**, convert it to usable data, and transmit the usable data to the one or more services via the network access device **106**. GPS unit **118** can receive position information from a constellation of satellites operated by the U.S. Department of Defense. Alternately, the GPS unit **118** can be a GLONASS receiver operated by the Russian Federation Ministry of Defense, or any other positioning device capable of providing accurate location information (for example, LORAN, inertial navigation, and the like). The GPS unit **118** can contain additional logic, either software, hardware or both to receive the Wide Area Augmentation System (WAAS) signals, operated by the Federal Aviation Administration, to correct dithering errors and provide the most accurate location possible. Overall accuracy of the positioning equipment subsystem containing WAAS is generally in the two meter range.

[0067] **FIG. 2** illustrates an exemplary vaporizer **200**. The vaporizer **200** can be, for example, an e-cigarette, an e-cigar, an electronic vapor device, a hybrid electronic communication handset coupled/integrated vapor device, a robotic vapor device, a modified vapor device "mod," a micro-sized electronic vapor device, a robotic vapor device, and the like. The vaporizer **200** can be used internally of the vapor device **100** or can be a separate device. For example, the vaporizer **200** can be used in place of the vaporizer **108**.

[0068] The vaporizer **200** can comprise or be coupled to one or more containers **202** containing a vaporizable material, for example a fluid. For example, coupling between the vaporizer **200** and the one or more containers **202** can be via a wick **204**, via a valve, or

by some other structure. Coupling can operate independently of gravity, such as by capillary action or pressure drop through a valve. The vaporizer **200** can be configured to vaporize the vaporizable material from the one or more containers **202** at controlled rates in response to mechanical input from a component of the vapor device **100**, and/or in response to control signals from the processor **102** or another component. Vaporizable material (e.g., fluid) can be supplied by one or more replaceable cartridges **206**. In an aspect the vaporizable material can comprise aromatic elements. In an aspect, the aromatic elements can be medicinal, recreational, and/or wellness related. The aromatic element can include, but is not limited to, at least one of lavender or other floral aromatic eLiquids, mint, menthol, herbal soil or geologic, plant based, name brand perfumes, custom mixed perfume formulated inside the vapor device **100** and aromas constructed to replicate the smell of different geographic places, conditions, and/or occurrences. For example, the smell of places may include specific or general sports venues, well known travel destinations, the mix of one's own personal space or home. The smell of conditions may include, for example, the smell of a pet, a baby, a season, a general environment (e.g., a forest), a new car, a sexual nature (e.g., musk, pheromones, etc.). The one or more replaceable cartridges **206** can contain the vaporizable material. If the vaporizable material is liquid, the cartridge can comprise the wick **204** to aid in transporting the liquid to a mixing chamber **208**. In the alternative, some other transport mode can be used. Each of the one or more replaceable cartridges **206** can be configured to fit inside and engage removably with a receptacle (such as the container **202** and/or a secondary container) of the vapor device **100**. In an alternative, or in addition, one or more fluid containers **210** can be fixed in the vapor device **100** and configured to be refillable. In an aspect, one or more materials can be vaporized at a single time by the vaporizer **200**. For example, some material can be vaporized and drawn through an exhaust port **212** and/or some material can be vaporized and exhausted via a smoke simulator outlet (not shown).

[0069] The mixing chamber **208** can also receive an amount of one or more compounds (e.g., vaporizable material) to be vaporized. For example, the processor **102** can determine a first amount of a first compound and determine a second amount of a second compound. The processor **102** can cause the withdrawal of the first amount of the first compound from a first container into the mixing chamber and the second amount of the second compound from a second container into the mixing chamber. The processor **102** can also determine a target dose of the first compound, determine a vaporization ratio of the first compound and the second compound based on the target dose, determine the first

amount of the first compound based on the vaporization ratio, determine the second amount of the second compound based on the vaporization ratio, and cause the withdrawal of the first amount of the first compound into the mixing chamber, and the withdrawal of the second amount of the second compound into the mixing chamber.

[0070] The processor **102** can also determine a vaporization rate. The vaporization rate can be an amount of vaporizable material vaporized over time. In an aspect, a vaporization rate can be determined a vaporizable material. In another aspect, a vaporization rate can be determined for each of a plurality of vaporizable materials. For example, in an embodiment of the vapor device **100** comprising two different vaporizable materials, each vaporizable material can have a vaporization rate. As a result, both vaporizable materials can be vaporized at the respective vaporization rate and the resulting vapors can be combined. In another aspect, the vaporization rates can be used to determine an amount of each vaporizable material to withdraw into the mixing element **122**. The resulting mixture of vaporizable material can then be vaporized. In a further aspect, each container **110** can comprise an independent vaporizer **108** configured to vaporize vaporizable material contained in a corresponding container at a vaporization rate. As a result, the different vaporizable materials can be vaporized independently, yet simultaneously or serially. Vaporization can be performed according to a vaporization rate determined for each vaporizable material.

[0071] The processor **102** can also determine a target dose of the first compound, determine a vaporization ratio of the first compound and the second compound based on the target dose, determine the first amount of the first compound based on the vaporization ratio, and determine the second amount of the second compound based on the vaporization ratio. After expelling the vapor through an exhaust port for inhalation by a user, the processor **102** can determine that a cumulative dose is approaching the target dose and reduce the vaporization ratio. In an aspect, one or more of the vaporization ratio, the target dose, and/or the cumulative dose can be determined remotely and transmitted to the vapor device **100** for use.

[0072] In operation, a heating element **214** can vaporize or nebulize the vaporizable material in the mixing chamber **208**, producing an inhalable vapor/mist that can be expelled via the exhaust port **212**. In an aspect, the vaporizer **200** can comprise a plurality of heating elements **214** configured to independently heat different vaporizable materials. In an aspect, the heating element **214** can comprise a heater coupled to the wick (or a heated wick) **204** operatively coupled to (for example, in fluid communication with) the

mixing chamber **210**. The heating element **214** can comprise a nickel-chromium wire or the like, with a temperature sensor (not shown) such as a thermistor or thermocouple. Within definable limits, by controlling power to the wick **204**, a rate of vaporization can be independently controlled. A multiplexer **216** can receive power from any suitable source and exchange data signals with a processor, for example, the processor **102** of the vapor device **100**, for control of the vaporizer **200**. At a minimum, control can be provided between no power (off state) and one or more powered states. Other control mechanisms can also be suitable.

[0073] In another aspect, the vaporizer **200** can comprise a piezoelectric dispersing element. In some aspects, the piezoelectric dispersing element can be charged by a battery, and can be driven by a processor on a circuit board. The circuit board can be produced using a polyimide such as Kapton, or other suitable material. The piezoelectric dispersing element can comprise a thin metal disc which causes dispersion of the fluid fed into the dispersing element via the wick or other soaked piece of organic material through vibration. Once in contact with the piezoelectric dispersing element, the vaporizable material (e.g., fluid) can be vaporized (e.g., turned into vapor or mist) and the vapor can be dispersed via a system pump and/or a sucking action of the user. In some aspects, the piezoelectric dispersing element can cause dispersion of the vaporizable material by producing ultrasonic vibrations. An electric field applied to a piezoelectric material within the piezoelectric element can cause ultrasonic expansion and contraction of the piezoelectric material, resulting in ultrasonic vibrations to the disc. The ultrasonic vibrations can cause the vaporizable material to disperse, thus forming a vapor or mist from the vaporizable material.

[0074] In an aspect, the vaporizer **200** can be configured to permit a user to select between using the heating element **214** or the piezoelectric dispersing element. In another aspect, the vaporizer **200** can be configured to permit a user to utilize both the heating element **214** and the piezoelectric dispersing element.

[0075] In some aspects, the connection between a power supply and the piezoelectric dispersing element can be facilitated using one or more conductive coils. The conductive coils can provide an ultrasonic power input to the piezoelectric dispersing element. For example, the signal carried by the coil can have a frequency of approximately **107.8** kHz. In some aspects, the piezoelectric dispersing element can comprise a piezoelectric dispersing element that can receive the ultrasonic signal transmitted from the power supply through the coils, and can cause vaporization of the vaporizable liquid by

producing ultrasonic vibrations. An ultrasonic electric field applied to a piezoelectric material within the piezoelectric element causes ultrasonic expansion and contraction of the piezoelectric material, resulting in ultrasonic vibrations according to the frequency of the signal. The vaporizable liquid can be vibrated by the ultrasonic energy produced by the piezoelectric dispersing element, thus causing dispersal and/or atomization of the liquid.

[0076] **FIG. 3** illustrates a vaporizer **300** that comprises the elements of the vaporizer **200** with two containers **202a** and **202b** containing a vaporizable material, for example a fluid or a solid. In an aspect, the fluid can be the same fluid in both containers or the fluid can be different in each container. In an aspect the fluid can comprise aromatic elements. The aromatic element can include, but is not limited to, at least one of lavender or other floral aromatic eLiquids, mint, menthol, herbal soil or geologic, plant based, name brand perfumes, custom mixed perfume formulated inside the vapor device **100** and aromas constructed to replicate the smell of different geographic places, conditions, and/or occurrences. For example, the smell of places may include specific or general sports venues, well known travel destinations, the mix of one's own personal space or home. The smell of conditions may include, for example, the smell of a pet, a baby, a season, a general environment (e.g., a forest), a new car, a sexual nature (e.g., musk, pheromones, etc.). Coupling between the vaporizer **200** and the container **202a** and the container **202b** can be via a wick **204a** and a wick **204b**, respectively, via a valve, or by some other structure. Coupling can operate independently of gravity, such as by capillary action or pressure drop through a valve. The vaporizer **300** can be configured to mix in varying proportions the fluids contained in the container **202a** and the container **202b** and vaporize the mixture at controlled rates in response to mechanical input from a component of the vapor device **100**, and/or in response to control signals from the processor **102** or another component. For example, based on a vaporization ratio. In an aspect, a mixing element **302** can be coupled to the container **202a** and the container **202b**. The mixing element can, in response to a control signal from the processor **102**, withdraw select quantities of vaporizable material in order to create a customized mixture of different types of vaporizable material. Vaporizable material (e.g., fluid) can be supplied by one or more replaceable cartridges **206a** and **206b**. The one or more replaceable cartridges **206a** and **206b** can contain a vaporizable material. If the vaporizable material is liquid, the cartridge can comprise the wick **204a** or **204b** to aid in transporting the liquid to a mixing chamber **208**. In the alternative, some other transport

mode can be used. Each of the one or more replaceable cartridges **206a** and **206b** can be configured to fit inside and engage removably with a receptacle (such as the container **202a** or the container **202b** and/or a secondary container) of the vapor device **100**. In an alternative, or in addition, one or more fluid containers **210a** and **210b** can be fixed in the vapor device **100** and configured to be refillable. In an aspect, one or more materials can be vaporized at a single time by the vaporizer **300**. For example, some material can be vaporized and drawn through an exhaust port **212** and/or some material can be vaporized and exhausted via a smoke simulator outlet (not shown).

[0077] **FIG. 4** illustrates a vaporizer **200** that comprises the elements of the vaporizer **200** with a heating casing **402**. The heating casing **402** can enclose the heating element **214** or can be adjacent to the heating element **214**. The heating casing **402** is illustrated with dashed lines, indicating components contained therein. The heating casing **402** can be made of ceramic, metal, and/or porcelain. The heating casing **402** can have varying thickness. In an aspect, the heating casing **402** can be coupled to the multiplexer **216** to receive power to heat the heating casing **402**. In another aspect, the heating casing **402** can be coupled to the heating element **214** to heat the heating casing **402**. In another aspect, the heating casing **402** can serve an insulation role.

[0078] **FIG. 5** illustrates the vaporizer **200** of **FIG. 2** and **FIG. 4**, but illustrates the heating casing **402** with solid lines, indicating components contained therein. Other placements of the heating casing **402** are contemplated. For example, the heating casing **402** can be placed after the heating element **214** and/or the mixing chamber **208**.

[0079] **FIG. 6** illustrates a vaporizer **600** that comprises the elements of the vaporizer **200** of **FIG. 2** and **FIG. 4**, with the addition of a cooling element **602**. The vaporizer **600** can optionally comprise the heating casing **402**. The cooling element **602** can comprise one or more of a powered cooling element, a cooling air system, and/or or a cooling fluid system. The cooling element **602** can be self-powered, co-powered, or directly powered by a battery and/or charging system within the vapor device **100** (e.g., the power supply **120**). In an aspect, the cooling element **602** can comprise an electrically connected conductive coil, grating, and/or other design to efficiently distribute cooling to the at least one of the vaporized and/or non-vaporized air. For example, the cooling element **602** can be configured to cool air as it is brought into the vaporizer **600**/mixing chamber **208** and/or to cool vapor after it exits the mixing chamber **208**. The cooling element **602** can be deployed such that the cooling element **602** is surrounded by the heated casing **402** and/or the heating element **214**. In another aspect, the heated casing **402** and/or the

heating element **214** can be surrounded by the cooling element **602**. The cooling element **602** can utilize at least one of cooled air, cooled liquid, and/or cooled matter.

[0080] In an aspect, the cooling element **602** can be a coil of any suitable length and can reside proximate to the inhalation point of the vapor (e.g., the exhaust port **212**). The temperature of the air is reduced as it travels through the cooling element **602**. In an aspect, the cooling element **602** can comprise any structure that accomplishes a cooling effect. For example, the cooling element **602** can be replaced with a screen with a mesh or grid-like structure, a conical structure, and/or a series of cooling airlocks, either stationary or opening, in a periscopic/telescopic manner. The cooling element **602** can be any shape and/or can take multiple forms capable of cooling heated air, which passes through its space.

[0081] In an aspect, the cooling element **602** can be any suitable cooling system for use in a vapor device. For example, a fan, a heat sink, a liquid cooling system, a chemical cooling system, combinations thereof, and the like. In an aspect, the cooling element **602** can comprise a liquid cooling system whereby a fluid (e.g., water) passes through pipes in the vaporizer **600**. As this fluid passes around the cooling element **602**, the fluid absorbs heat, cooling air in the cooling element **602**. After the fluid absorbs the heat, the fluid can pass through a heat exchanger which transfers the heat from the fluid to air blowing through the heat exchanger. By way of further example, the cooling element **602** can comprise a chemical cooling system that utilizes an endothermic reaction. An example of an endothermic reaction is dissolving ammonium nitrate in water. Such endothermic process is used in instant cold packs. These cold packs have a strong outer plastic layer that holds a bag of water and a chemical, or mixture of chemicals, that result in an endothermic reaction when dissolved in water. When the cold pack is squeezed, the inner bag of water breaks and the water mixes with the chemicals. The cold pack starts to cool as soon as the inner bag is broken, and stays cold for over an hour. Many instant cold packs contain ammonium nitrate. When ammonium nitrate is dissolved in water, it splits into positive ammonium ions and negative nitrate ions. In the process of dissolving, the water molecules contribute energy, and as a result, the water cools down. Thus, the vaporizer **600** can comprise a chamber for receiving the cooling element **602** in the form of a "cold pack." The cold pack can be activated prior to insertion into the vaporizer **600** or can be activated after insertion through use of a button/switch and the like to mechanically activate the cold pack inside the vaporizer **400**.

[0082] In an aspect, the cooling element **602** can be selectively moved within the vaporizer **600** to control the temperature of the air mixing with vapor. For example, the cooling element **602** can be moved closer to the exhaust port **212** or further from the exhaust port **212** to regulate temperature. In another aspect, insulation can be incorporated as needed to maintain the integrity of heating and cooling, as well as absorbing any unwanted condensation due to internal or external conditions, or a combination thereof. The insulation can also be selectively moved within the vaporizer **600** to control the temperature of the air mixing with vapor. For example, the insulation can be moved to cover a portion, none, or all of the cooling element **602** to regulate temperature.

[0083] **FIG. 7** illustrates a vaporizer **700** that comprises elements in common with the vaporizer **200**. The vaporizer **700** can optionally comprise the heating casing **402** (not shown) and/or the cooling element **602** (not shown). The vaporizer **700** can comprise a magnetic element **702**. The magnetic element **702** can apply a magnetic field to vapor after exiting the mixing chamber **208**. The magnetic field can cause positively and negatively charged particles in the vapor to curve in opposite directions, according to the Lorentz force law with two particles of opposite charge. The magnetic field can be created by at least one of an electric current generating a charge or a pre-charged magnetic material deployed within the vapor device **100**. In an aspect, the magnetic element **702** can be built into the mixing chamber **208**, the cooling element **602**, the heating casing **402**, or can be a separate magnetic element **702**.

[0084] **FIG. 8** illustrates a vaporizer **800** that comprises elements in common with the vaporizer **200**. In an aspect, the vaporizer **800** can comprise a filtration element **802**. The filtration element **802** can be configured to remove (e.g., filter, purify, etc) contaminants from air entering the vaporizer **800**. The filtration element **802** can optionally comprise a fan **804** to assist in delivering air to the filtration element **802**. The vaporizer **800** can be configured to intake air into the filtration element **802**, filter the air, and pass the filtered air to the mixing chamber **208** for use in vaporizing the one or more vaporizable or non-vaporizable materials. In another aspect, the vaporizer **800** can be configured to intake air into the filtration element **802**, filter the air, and bypass the mixing chamber **208** by engaging a door **806** and a door **808** to pass the filtered air directly to the exhaust port **212** for inhalation by a user. In an aspect, filtered air that bypasses the mixing chamber **208** by engaging the door **806** and the door **808** can pass through a second filtration element **810** to further remove (e.g., filter, purify, etc) contaminants from air entering the vaporizer **800**. In an aspect, the vaporizer **800** can be configured to deploy and/or mix a proper/safe

amount of oxygen which can be delivered either via the one or more replaceable cartridges **206** or via air pumped into a mask from external air and filtered through the filtration element **802** and/or the filtration element **810**.

[0085] In an aspect, the filtration element **802** and/or the filtration element **810** can comprise cotton, polymer, wool, satin, meta materials and the like. The filtration element **802** and/or the filtration element **810** can comprise a filter material that at least one airborne particle and/or undesired gas by a mechanical mechanism, an electrical mechanism, and/or a chemical mechanism. The filter material can comprise one or more pieces of, a filter fabric that can filter out one or more airborne particles and/or gasses. The filter fabric can be a woven and/or non-woven material. The filter fabric can be made from natural fibers (e.g., cotton, wool, etc.) and/or from synthetic fibers (e.g., polyester, nylon, polypropylene, etc.). The thickness of the filter fabric can be varied depending on the desired filter efficiencies and/or the region of the apparel where the filter fabric is to be used. The filter fabric can be designed to filter airborne particles and/or gasses by mechanical mechanisms (e.g., weave density), by electrical mechanisms (e.g., charged fibers, charged metals, etc.), and/or by chemical mechanisms (e.g., absorptive charcoal particles, adsorptive materials, etc.). In an aspect, the filter material can comprise electrically charged fibers such as, but not limited to, FILTRETTE by 3M. In another aspect, the filter material can comprise a high density material similar to material used for medical masks which are used by medical personnel in doctors' offices, hospitals, and the like. In an aspect, the filter material can be treated with an anti-bacterial solution and/or otherwise made from anti-bacterial materials. In another aspect, the filtration element **802** and/or the filtration element **810** can comprise electrostatic plates, ultraviolet light, a HEPA filter, combinations thereof, and the like.

[0086] **FIG. 9** illustrates an exemplary vapor device **900**. The exemplary vapor device **900** can comprise the vapor device **100** and/or any of the vaporizers disclosed herein. The exemplary vapor device **900** illustrates a display **902**. The display **902** can be a touchscreen. The display **902** can be configured to enable a user to control any and/or all functionality of the exemplary vapor device **900**. For example, a user can utilize the display **902** to enter a pass code to lock and/or unlock the exemplary vapor device **900**. The exemplary vapor device **900** can comprise a biometric interface **904**. For example, the biometric interface **904** can comprise a fingerprint scanner, an eye scanner, a facial scanner, and the like. The biometric interface **904** can be configured to enable a user to control any and/or all functionality of the exemplary vapor device **900**. The exemplary

vapor device **900** can comprise an audio interface **906**. The audio interface **906** can comprise a button that, when engaged, enables a microphone **908**. The microphone **908** can receive audio signals and provide the audio signals to a processor for interpretation into one or more commands to control one or more functions of the exemplary vapor device **900**.

[0087] **FIG. 10** illustrates exemplary information that can be provided to a user via the display **902** of the exemplary vapor device **900**. The display **902** can provide information to a user such as a puff count, an amount of vaporizable material remaining in one or more containers, battery remaining, signal strength, combinations thereof, and the like.

[0088] **FIG. 11** illustrates a series of user interfaces that can be provided via the display **902** of the exemplary vapor device **900**. In an aspect, the exemplary vapor device **900** can be configured for one or more of multi-mode vapor usage. For example, the exemplary vapor device **900** can be configured to enable a user to inhale vapor (vape mode) or to release vapor into the atmosphere (aroma mode). User interface **1100a** provides a user with interface elements to select which mode the user wishes to engage, a Vape Mode **1102**, an Aroma Mode **1104**, or an option to go back **1106** and return to the previous screen. The interface element Vape Mode **1102** enables a user to engage a vaporizer to generate a vapor for inhalation. The interface element Aroma Mode **1104** enables a user to engage the vaporizer to generate a vapor for release into the atmosphere.

[0089] In the event a user selects the Vape Mode **1102**, the exemplary vapor device **900** will be configured to vaporize material and provide the resulting vapor to the user for inhalation. The user can be presented with user interface **1100b** which provides the user an option to select interface elements that will determine which vaporizable material to vaporize. For example, an option of Mix 1 **1108**, Mix 2 **1110**, or a New Mix **1112**. The interface element Mix 1 **1108** enables a user to engage one or more containers that contain vaporizable material in a predefined amount and/or ratio. In an aspect, a selection of Mix 1 **1108** can result in the exemplary vapor device **900** engaging a single container containing a single type of vaporizable material or engaging a plurality of containers containing a different types of vaporizable material in varying amounts. The interface element Mix 2 **1110** enables a user to engage one or more containers that contain vaporizable material in a predefined amount and/or ratio. In an aspect, a selection of Mix 2 **1110** can result in the exemplary vapor device **900** engaging a single container containing a single type of vaporizable material or engaging a plurality of containers containing a different types of vaporizable material in varying amounts. In an aspect, a

selection of New Mix **1112** can result in the exemplary vapor device **900** receiving a new mixture, formula, recipe, etc... of vaporizable materials and/or engage one or more containers that contain vaporizable material in the new mixture.

[0090] Upon selecting, for example, the Mix 1 **1108**, the user can be presented with user interface **1100c**. User interface **1100c** indicates to the user that Mix 1 has been selected via an indicator **1114**. The user can be presented with options that control how the user wishes to experience the selected vapor. The user can be presented with interface elements Cool **1116**, Filter **1118**, and Smooth **1120**. The interface element Cool **1116** enables a user to engage one or more cooling elements to reduce the temperature of the vapor. The interface element Filter **1118** enables a user to engage one or more filter elements to filter the air used in the vaporization process. The interface element Smooth **1120** enables a user to engage one or more heating casings, cooling elements, filter elements, and/or magnetic elements to provide the user with a smoother vaping experience.

[0091] Upon selecting New Mix **1112**, the user can be presented with user interface **1100d**. User interface **1100d** provides the user with a container one ratio interface element **1122**, a container two ratio interface element **1124**, and Save **1126**. The container one ratio interface element **1122** and the container two ratio interface element **1124** provide a user the ability to select an amount of each type of vaporizable material contained in container one and/or container two to utilize as a new mix. The container one ratio interface element **1122** and the container two ratio interface element **1124** can provide a user with a slider that adjusts the percentages of each type of vaporizable material based on the user dragging the slider. In an aspect, a mix can comprise **100%** on one type of vaporizable material or any percent combination (e.g., 50/50, 75/25, 85/15, 95/5, etc. ...). Once the user is satisfied with the new mix, the user can select Save **1126** to save the new mix for later use.

[0092] In the event a user selects the Aroma Mode **1104**, the exemplary vapor device **900** will be configured to vaporize material and release the resulting vapor into the atmosphere. The user can be presented with user interface **1100b**, **1100c**, and/or **1100d** as described above, but the resulting vapor will be released to the atmosphere.

[0093] In an aspect, the user can be presented with user interface **1100e**. The user interface **1100e** can provide the user with interface elements Identify **1128**, Save **1130**, and Upload **1132**. The interface element Identify **1128** enables a user to engage one or more sensors in the exemplary vapor device **900** to analyze the surrounding environment.

For example, activating the interface element Identify **1128** can engage a sensor to determine the presence of a negative environmental condition such as smoke, a bad smell, chemicals, etc. Activating the interface element Identify **1128** can engage a sensor to determine the presence of a positive environmental condition, for example, an aroma. The interface element Save **1130** enables a user to save data related to the analyzed negative and/or positive environmental condition in memory local to the exemplary vapor device **900**. The interface element Upload **1132** enables a user to engage a network access device to transmit data related to the analyzed negative and/or positive environmental condition to a remote server for storage and/or analysis.

[0094] In one aspect of the disclosure, a system can be configured to provide services such as network-related services to a user device. **FIG. 12** illustrates various aspects of an exemplary environment in which the present methods and systems can operate. The present disclosure is relevant to systems and methods for providing services to a user device, for example, electronic vapor devices which can include, but are not limited to, a vape-bot, micro-vapor device, vapor pipe, e-cigarette, hybrid handset and vapor device, and the like. Other user devices that can be used in the systems and methods include, but are not limited to, a smart watch (and any other form of "smart" wearable technology), a smartphone, a tablet, a laptop, a desktop, and the like. In an aspect, one or more network devices can be configured to provide various services to one or more devices, such as devices located at or near a premises. In another aspect, the network devices can be configured to recognize an authoritative device for the premises and/or a particular service or services available at the premises. As an example, an authoritative device can be configured to govern or enable connectivity to a network such as the Internet or other remote resources, provide address and/or configuration services like DHCP, and/or provide naming or service discovery services for a premises, or a combination thereof. Those skilled in the art will appreciate that present methods can be used in various types of networks and systems that employ both digital and analog equipment. One skilled in the art will appreciate that provided herein is a functional description and that the respective functions can be performed by software, hardware, or a combination of software and hardware.

[0095] The network and system can comprise a user device **1202a**, **1202b**, and/or **1202c** in communication with a computing device **1204** such as a server, for example. The computing device **1204** can be disposed locally or remotely relative to the user device **1202a**, **1202b**, and/or **1202c**. As an example, the user device **1202a**, **1202b**, and/or **1202c**

and the computing device **1204** can be in communication via a private and/or public network **1220** such as the Internet or a local area network. Other forms of communications can be used such as wired and wireless telecommunication channels, for example. In another aspect, the user device **1202a**, **1202b**, and/or **1202c** can communicate directly without the use of the network **1220** (for example, via Bluetooth®, infrared, and the like).

[0096] In an aspect, the user device **1202a**, **1202b**, and/or **1202c** can be an electronic device such as an electronic vapor device (e.g., vape-bot, micro-vapor device, vapor pipe, e-cigarette, hybrid handset and vapor device), a smartphone, a smart watch, a computer, a smartphone, a laptop, a tablet, a set top box, a display device, or other device capable of communicating with the computing device **1204**. As an example, the user device **1202a**, **1202b**, and/or **1202c** can comprise a communication element **1206** for providing an interface to a user to interact with the user device **1202a**, **1202b**, and/or **1202c** and/or the computing device **1204**. The communication element **1206** can be any interface for presenting and/or receiving information to/from the user, such as user feedback. An example interface can be communication interface such as a web browser (e.g., Internet Explorer, Mozilla Firefox, Google Chrome, Safari, or the like). Other software, hardware, and/or interfaces can be used to provide communication between the user and one or more of the user device **1202a**, **1202b**, and/or **1202c** and the computing device **1204**. In an aspect, the user device **1202a**, **1202b**, and/or **1202c** can have at least one similar interface quality such as a symbol, a voice activation protocol, a graphical coherence, a startup sequence continuity element of sound, light, vibration or symbol. In an aspect, the interface can comprise at least one of lighted signal lights, gauges, boxes, forms, words, video, audio scrolling, user selection systems, vibrations, check marks, avatars, matrix', visual images, graphic designs, lists, active calibrations or calculations, 2D interactive fractal designs, 3D fractal designs, 2D and/or 3D representations of vapor devices and other interface system functions.

[0097] As an example, the communication element **1206** can request or query various files from a local source and/or a remote source. As a further example, the communication element **1206** can transmit data to a local or remote device such as the computing device **1204**. In an aspect, data can be shared anonymously with the computing device **1204**. The data can be shared over a transient data session with the computing device **1204**. The transient data session can comprise a session limit. The session limit can be based on one or more of a number of puffs, a time limit, and a total

quantity of vaporizable material. The data can comprise usage data and/or a usage profile. The computing device **1204** can destroy the data once the session limit is reached.

[0098] In an aspect, the user device **1202a**, **1202b**, and/or **1202c** can be associated with a user identifier or device identifier **1208a**, **1208b**, and/or **1208c**. As an example, the device identifier **1208a**, **1208b**, and/or **1208c** can be any identifier, token, character, string, or the like, for differentiating one user or user device (e.g., user device **1202a**, **1202b**, and/or **1202c**) from another user or user device. In a further aspect, the device identifier **1208a**, **1208b**, and/or **1208c** can identify a user or user device as belonging to a particular class of users or user devices. As a further example, the device identifier **1208a**, **1208b**, and/or **1208c** can comprise information relating to the user device such as a manufacturer, a model or type of device, a service provider associated with the user device **1202a**, **1202b**, and/or **1202c**, a state of the user device **1202a**, **1202b**, and/or **1202c**, a locator, and/or a label or classifier. Other information can be represented by the device identifier **1208a**, **1208b**, and/or **1208c**.

[0099] In an aspect, the device identifier **1208a**, **1208b**, and/or **1208c** can comprise an address element **1210** and a service element **1212**. In an aspect, the address element **1210** can comprise or provide an internet protocol address, a network address, a media access control (MAC) address, an Internet address, or the like. As an example, the address element **1210** can be relied upon to establish a communication session between the user device **1202a**, **1202b**, and/or **1202c** and the computing device **1204** or other devices and/or networks. As a further example, the address element **1210** can be used as an identifier or locator of the user device **1202a**, **1202b**, and/or **1202c**. In an aspect, the address element **1210** can be persistent for a particular network.

[00100] In an aspect, the service element **1212** can comprise an identification of a service provider associated with the user device **1202a**, **1202b**, and/or **1202c** and/or with the class of user device **1202a**, **1202b**, and/or **1202c**. The class of the user device **1202a**, **1202b**, and/or **1202c** can be related to a type of device, capability of device, type of service being provided, and/or a level of service. As an example, the service element **1212** can comprise information relating to or provided by a communication service provider (e.g., Internet service provider) that is providing or enabling data flow such as communication services to and/or between the user device **1202a**, **1202b**, and/or **1202c**. As a further example, the service element **1212** can comprise information relating to a preferred service provider for one or more particular services relating to the user device **1202a**, **1202b**, and/or **1202c**. In an aspect, the address element **1210** can be used to identify or

retrieve data from the service element **1212**, or vice versa. As a further example, one or more of the address element **1210** and the service element **1212** can be stored remotely from the user device **1202a**, **1202b**, and/or **1202c** and retrieved by one or more devices such as the user device **1202a**, **1202b**, and/or **1202c** and the computing device **1204**. Other information can be represented by the service element **1212**.

[00101] In an aspect, the computing device **1204** can be a server for communicating with the user device **1202a**, **1202b**, and/or **1202c**. As an example, the computing device **1204** can communicate with the user device **1202a**, **1202b**, and/or **1202c** for providing data and/or services. As an example, the computing device **1204** can provide services such as data sharing, data syncing, network (e.g., Internet) connectivity, network printing, media management (e.g., media server), content services, streaming services, broadband services, or other network-related services. In an aspect, the computing device **1204** can allow the user device **1202a**, **1202b**, and/or **1202c** to interact with remote resources such as data, devices, and files. As an example, the computing device can be configured as (or disposed at) a central location, which can receive content (e.g., data) from multiple sources, for example, user devices **1202a**, **1202b**, and/or **1202c**. The computing device **1204** can combine the content from the multiple sources and can distribute the content to user (e.g., subscriber) locations via a distribution system.

[00102] In an aspect, one or more network devices **1216** can be in communication with a network such as network **1220**. As an example, one or more of the network devices **1216** can facilitate the connection of a device, such as user device **1202a**, **1202b**, and/or **1202c**, to the network **1220**. As a further example, one or more of the network devices **1216** can be configured as a wireless access point (WAP). In an aspect, one or more network devices **1216** can be configured to allow one or more wireless devices to connect to a wired and/or wireless network using Wi-Fi, Bluetooth or any desired method or standard.

[00103] In an aspect, the network devices **1216** can be configured as a local area network (LAN). As an example, one or more network devices **1216** can comprise a dual band wireless access point. As an example, the network devices **1216** can be configured with a first service set identifier (SSID) (e.g., associated with a user network or private network) to function as a local network for a particular user or users. As a further example, the network devices **1216** can be configured with a second service set identifier (SSID) (e.g., associated with a public/community network or a hidden network) to function as a secondary network or redundant network for connected communication devices.

[00104] In an aspect, one or more network devices **1216** can comprise an identifier **1218**. As an example, one or more identifiers can be or relate to an Internet Protocol (IP) Address IPV4/IPV6 or a media access control address (MAC address) or the like. As a further example, one or more identifiers **1218** can be a unique identifier for facilitating communications on the physical network segment. In an aspect, each of the network devices **1216** can comprise a distinct identifier **1218**. As an example, the identifiers **1218** can be associated with a physical location of the network devices **1216**.

[00105] In an aspect, the computing device **1204** can manage the communication between the user device **1202a**, **1202b**, and/or **1202c** and a database **1214** for sending and receiving data therebetween. As an example, the database **1214** can store a plurality of files (e.g., web pages), user identifiers or records, or other information. In one aspect, the database **1214** can store user device **1202a**, **1202b**, and/or **1202c** usage information (including chronological usage), type of vaporizable and/or non-vaporizable material used, frequency of usage, location of usage, recommendations, communications (e.g., text messages, advertisements, photo messages), simultaneous use of multiple devices, and the like). The database **1214** can collect and store data to support cohesive use, wherein cohesive use is indicative of the use of a first electronic vapor devices and then a second electronic vapor device is synced chronologically and logically to provide the proper specific properties and amount of vapor based upon a designed usage cycle. As a further example, the user device **1202a**, **1202b**, and/or **1202c** can request and/or retrieve a file from the database **1214**. The user device **1202a**, **1202b**, and/or **1202c** can thus sync locally stored data with more current data available from the database **1214**. Such syncing can be set to occur automatically on a set time schedule, on demand, and/or in real-time. The computing device **1204** can be configured to control syncing functionality. For example, a user can select one or more of the user device **1202a**, **1202b**, and/or **1202c** to never be synced, to be the master data source for syncing, and the like. Such functionality can be configured to be controlled by a master user and any other user authorized by the master user or agreement.

[00106] In an aspect, data can be derived by system and/or device analysis. Such analysis can comprise at least by one of instant analysis performed by the user device **1202a**, **1202b**, and/or **1202c** or archival data transmitted to a third party for analysis and returned to the user device **1202a**, **1202b**, and/or **1202c** and/or computing device **1204**. The result of either data analysis can be communicated to a user of the user device **1202a**, **1202b**,

and/or **1202c** to, for example, inform the user of their eVapor use and/or lifestyle options. In an aspect, a result can be transmitted back to at least one authorized user interface.

[001 07] In an aspect, the database **1214** can store information relating to the user device **1202a**, **1202b**, and/or **1202c** such as the address element **1210** and/or the service element **1212**. As an example, the computing device **1204** can obtain the device identifier **1208a**, **1208b**, and/or **1208c** from the user device **1202a**, **1202b**, and/or **1202c** and retrieve information from the database **1214** such as the address element **1210** and/or the service elements **1212**. As a further example, the computing device **1204** can obtain the address element **1210** from the user device **1202a**, **1202b**, and/or **1202c** and can retrieve the service element **1212** from the database **1214**, or vice versa. Any information can be stored in and retrieved from the database **1214**. The database **1214** can be disposed remotely from the computing device **1204** and accessed via direct or indirect connection. The database **1214** can be integrated with the computing device **1204** or some other device or system. Data stored in the database **1214** can be stored anonymously and can be destroyed based on a transient data session reaching a session limit.

[001 08] **FIG. 13** illustrates an ecosystem **1300** configured for sharing and/or syncing data such as usage information (including chronological usage), type of vaporizable and/or non-vaporizable material used, frequency of usage, location of usage, recommendations, communications (e.g., text messages, advertisements, photo messages), simultaneous use of multiple devices, and the like) between one or more devices such as a vapor device **1302**, a vapor device **1304**, a vapor device **1306**, and an electronic communication device **1308**. In an aspect, the vapor device **1302**, the vapor device **1304**, the vapor device **1306** can be one or more of an e-cigarette, an e-cigar, an electronic vapor modified device, a hybrid electronic communication handset coupled/integrated vapor device, a micro-sized electronic vapor device, or a robotic vapor device. In an aspect, the electronic communication device **1308** can comprise one or more of a smartphone, a smart watch, a tablet, a laptop, and the like.

[001 09] In an aspect data generated, gathered, created, etc., by one or more of the vapor device **1302**, the vapor device **1304**, the vapor device **1306**, and/or the electronic communication device **1308** can be uploaded to and/or downloaded from a central server **1310** via a network **1312**, such as the Internet. Such uploading and/or downloading can be performed via any form of communication including wired and/or wireless. In an aspect, the vapor device **1302**, the vapor device **1304**, the vapor device **1306**, and/or the electronic communication device **1308** can be configured to communicate via cellular

communication, WiFi communication, Bluetooth® communication, satellite communication, and the like. The central server **1310** can store uploaded data and associate the uploaded data with a user and/or device that uploaded the data. The central server **1310** can access unified account and tracking information to determine devices that are associated with each other, for example devices that are owned/used by the same user. The central server **1310** can utilize the unified account and tracking information to determine which of the vapor device **1302**, the vapor device **1304**, the vapor device **1306**, and/or the electronic communication device **1308**, if any, should receive data uploaded to the central server **1310**.

[001 10] In an aspect, the uploading and downloading can be performed anonymously. The data can be shared over a transient data session with the central server **1310**. The transient data session can comprise a session limit. The session limit can be based on one or more of a number of puffs, a time limit, and a total quantity of vaporizable material. The data can comprise usage data and/or a usage profile. The central server **1310** can destroy the data once the session limit is reached. While the transient data session is active, the central server **1310** can provide a usage profile to one of the vapor device **1302**, the vapor device **1304**, the vapor device **1306** to control the functionality for the duration of the transient data session.

[001 11] For example, the vapor device **1302** can be configured to upload usage information related to vaporizable material consumed and the electronic communication device **1308** can be configured to upload location information related to location of the vapor device **1302**. The central server **1310** can receive both the usage information and the location information, access the unified account and tracking information to determine that both the vapor device **1302** and the electronic communication device **1308** are associated with the same user. The central server **1310** can thus correlate the user's location along with the type, amount, and/or timing of usage of the vaporizable material. The central server **1310** can further determine which of the other devices are permitted to receive such information and transmit the information based on the determined permissions. In an aspect, the central server **1310** can transmit the correlated information to the electronic communication device **1308** which can then subsequently use the correlated information to recommend a specific type of vaporizable material to the user when the user is located in the same geographic position indicated by the location information.

[001 12] In another aspect, the central server **1310** can provide one or more social networking services for users of the vapor device **1302**, the vapor device **1304**, the vapor device **1306**, and/or the electronic communication device **1308**. Such social networking services include, but are not limited to, messaging (e.g., text, image, and/or video), mixture sharing, product recommendations, location sharing, product ordering, and the like.

[001 13] Referring to **FIG. 14**, a system **1400** may be configured to interchangeably deliver one or both of apparatus for providing nebulized and non-nebulized materials in an inhalable form. The system **1400** may comprise an electronic hybrid vapor device (also described herein as a hybrid vaporizer **1411**). In one embodiment, the hybrid vaporizer **1411** is, or includes, an electronic cigarette. In other embodiments, the hybrid vaporizer **1411** is or includes a modified electronic vapor device coupled with a communication device, a hybrid vaporizer **1411** suited to fill a room or proscribed area with vapor, a hookah delivery system via a vapor device, or a portable vapor device. Although described herein, frequently, as a personal hybrid vaporizer **1411** for individual use, such as in an e-cigarette, this disclosure is intended to cover any apparatus for providing nebulized and non-nebulized materials in an inhalable form including one for providing a vaporized compound to a room or proscribed area.

[001 14] The hybrid vaporizer **1411** may provide a compound in an inhalable form to promote health through treatment of one or more conditions. For example, hybrid vaporizer **1411** may provide a compound in an inhalable form provided to enhance wellness, for recreational enjoyment, for pleasurable sensation, to enhance healing, and/or treat medical conditions comprising one or more of: dementia, seizures, pain, cognitive deficiencies, glaucoma, diet control, and depression.

[001 15] In accordance with various aspects, the hybrid vaporizer **1411** may comprise a first container **1408**, a second container **1409**, and a mixing chamber **1405**. The hybrid vaporizer **1411** may further comprise a vapor chamber **1403**, a vapor port **1402**, and a processor **1407**. In various embodiments, the hybrid vaporizer **1411** may comprise a vaporizing section **1404**. The hybrid vaporizer **1411** may also comprise a sensor **1401**.

[001 16] The first container **1408** is configured to hold a first compound. In an example embodiment, the first compound contains at least a vaporizable material and non-nebulizable material. In various example embodiments, the vaporizable material can comprise one of nicotine, cannabidiol (CBD), tetrahydrocannabinol (THC), cannabinol (CBN), and other health promoting cannabinoids.

[00117] The second container **1409** is configured to hold a second compound. In an example embodiment, the second compound contains at least a nebulizable but non-vaporizable material. For example, the non-vaporizable material may comprise at least one of a medicine, a vitamin, an aromatic liquid.

[00118] It should be appreciated that the distinction between a vaporizable material and a non-vaporizable material may depend primarily on the vaporization conditions. These conditions may include, for example, composition and pressure of the gaseous mixture in which the vaporization occurs, temperature of the vaporization process, and the type of vaporizing apparatus used. The present application is primarily concerned with personal vaporizers/nebulizers that operate in air at or near one atmosphere of pressure, using a vaporizing temperature that is below the ignition temperature for commonplace dry organic compounds. For example, a vaporizing temperature in the range of about 150-400 degrees Fahrenheit may be suitable, although the technology is not limited to this range. A first material may be vaporized without being degraded under such conditions, and is therefore considered vaporizable. A second material may be substantially degraded under the same conditions, for example by oxidation, so is not considered vaporizable under the specified conditions. A third material may not vaporize at all under these conditions, so is not considered vaporizable under the specified conditions. Accordingly, vaporizability of a material should be assessed relative to a specified set of vaporizing conditions. These conditions, in turn, depend on the capabilities of the vaporizer or vaporizers that a vaporizing apparatus is equipped with, and the environment for which it is intended.

[00119] Likewise, the distinction between a nebulizable material and a non-nebulizable material may depend primarily on the nebulizing conditions. These conditions may include, for example, composition and pressure of the gaseous mixture in which the nebulizing occurs, the pressure differential of the process, fluid velocity, and the structure and mechanics of the nebulizing equipment. The present application is primarily concerned with personal vaporizers/nebulizers that operate in air at or near one atmosphere of pressure. A first material may not be capable of being nebulized under a given set of nebulizing conditions. For example, many solid materials and viscous oils or waxes are difficult to nebulize. A second material may be easily nebulized while being difficult to vaporize under the specified conditions. For example, many aqueous solutions lose their effectiveness if dried and will not vaporize at all below the boiling point of water. However, aqueous solutions are easily nebulized because of the relatively low viscosity and high surface tension of their aqueous solvent. Accordingly, nebulizability of

a material should be assessed relative to a specified set of nebulizing conditions. These conditions, in turn, depend on the capabilities of the nebulizer or nebulizers that a vaporizers/nebulizers apparatus is equipped with, and the environment for which it is intended.

[00120] In various embodiments, at least one of the first compound, and second compound are a fluid, such as a compressed gas, compressed liquid, or uncompressed liquid. In other embodiments, at least one of the first compound and second compound is a solid.

[00121] The first container **1408** and/or the second container **1409** may be formed of any suitable material for holding the respective compounds, and may have any suitable form factor for the herein described purposes.

[00122] The mixing chamber **1405** may be connected to the first container **1408** and the second container **1409** for receiving, in a controlled manner, at least one of the first compound and the second compound. The mixing chamber **1405** may be configured to provide a mixed compound to the vaporizing section **1404**.

[00123] The mixing chamber **1405** may receive the first and second compounds in a controlled manner at rates determined by the processor **1407** as described further herein. Each of the first and second compounds may be delivered to the mixing chamber **1405** at a different rate from the other compound. Moreover, the rate may vary from as little as no flow, to full flow (i.e., 0% to 100% of maximum delivery capacity). Thus, the mixed compound delivered to the vaporizing section **1404** may have any proportional make-up of the three different compounds, as determined by the processor **1407**. The flow from each of the first container **1408** and second container **1409** may be controlled by variable controlled valves, adjustable wicks, or other suitable devices for controlling the flow of the various compounds.

[00124] Vaporizing section **1404** may be connected to the mixing chamber **1405** and be configured to receive the mixed compound. Vaporizing section **1404** may be configured to vaporize the first compound (the vaporizable material) of the mixed compound. In one example embodiment, the vaporizing section **1404** comprises a heating material for vaporizing/atomizing the vaporizable material of the mixed compound.

[00125] The apparatus may include a separate nebulizing section for converting the non-vaporizable material (second compound) into an inhalable mist. For example, the apparatus **1400** may include a nebulizing section comprising a vibrating mesh for nebulizing the vaporizable material of the mixed compound into a mist, an atomizer for atomizing the vaporizable material of the mixed compound into an aerosol, or an

ultrasonic nebulizer for nebulizing the vaporizable material of the mixed compound into a mist. The nebulizing section may include a heating element, as well. Likewise, the vaporizing section **1404** may include a nebulizing element. In any configuration, the hybrid vaporizer **1411** performs one or more of vaporization, nebulization, or atomization, using at least two separate and distinct processes under distinct operating conditions, for different materials.

[00126] In another example embodiment, the hybrid vaporizer **1411** may be configured to first vaporize the vaporizable material of the first compound, then mix the vaporized material with the non-vaporizable material in the mixing chamber **1405**. The mixed vaporized and non-vaporized materials could then be passed from the mixing chamber **1405** through the vapor chamber **1403** and vapor port **1402** to the user of the hybrid vaporizer **1411**. Thus, the location of the vaporizing section may be before or after the mixing chamber, and/or may be associated with only the first container, in one example embodiment.

[00127] Various electronic vaporizing devices are known in the art, and are frequently being improved on. For example, details of a recent "Vapor Delivery Device" are disclosed by the inventor hereof in U.S. Patent Publication No. 2015/0047661, incorporated herein by reference. While the referenced publication provides a pertinent example of a vaporizer, it should be appreciated that various different designs for vaporizing devices are known in the art and may be adapted for use with the technology disclosed herein by one of ordinary skill.

[00128] Typically, a nebulizer uses oxygen, compressed air or ultrasonic power to break up medical solutions and suspensions into small aerosol droplets that may be directly inhaled from the mouthpiece of the device. An aerosol is a "mixture of gas and liquid particles," such as a mist, formed when small vaporized water particles mixed with hot ambient air are cooled down and condense into a fine cloud of visible airborne water droplets. Like a vaporizer, a nebulizer may produce an aerosol within the meaning of "vapor" as defined herein. A nebulizer may be distinguished from a vaporizer by the process used to provide the aerosol. A nebulizer does not rely primarily on heat to create an aerosol, unlike a vaporizer. However, both vaporizers and nebulizers may share similar elements.

[00129] Another typical nebulizer may comprise a vibrating mesh/membrane with laser drilled holes. The vibrating mesh creates a mist of fine droplets through the holes. Yet another typical nebulizer is known as an atomizer or "jet nebulizer." An atomizer is

connected by tubing to a compressor that causes compressed air or oxygen to flow at high velocity through a liquid medicine to turn it into an aerosol, which is then inhaled by the patient. Another typical nebulizer is an ultrasonic wave nebulizer, whereby an electronic oscillator generates a high frequency ultrasonic wave, which causes the mechanical vibration of a piezoelectric material. This vibrating material is in contact with a liquid reservoir and its high frequency vibration produces a vapor mist.

[00130] It is noted that the vaporization in vaporizing section **1404** may be effectuated via a single vaporizing component, or through multiple vaporizing components. In one example, more than one a separate vaporizing component is associated with container **1408**. Moreover, these vaporizing components may be configured to first vaporize the individual compounds and then mix the resulting vapors. Likewise, a nebulizing section may include one or more nebulizing components, and may be configured in parallel to the vaporizing section.

[00131] The vapor chamber **1403**, of hybrid vaporizer **1411**, may be connected to the vaporizing section **1404** and to a parallel nebulizing section. The vapor chamber **1403** may be configured to receive the mixed vaporized and non-vaporized materials (the "output vapor") from the mixing chamber **1405**, the vaporizing section **1404**, the nebulizing section, or a combination of the foregoing. The vapor chamber **1403** may function to serve as a spacer, to allow the output vapor to cool, to provide greater uniformity of the output vapor, and or the like.

[00132] The vapor port **1402** may be connected to the vapor chamber **1403**. The vapor port **1402** may be configured to receive the output vapor from the vapor chamber **1403**. The vapor port **1402** may be configured for interaction with a person to whom the compound is being administered. Thus, a person may put their mouth to the vapor port **1402** and apply suction to the vapor port **1402** in order to inhale the output vapor.

[00133] In various embodiments, hybrid vaporizer **1411** further comprises a sensor **1401**. The sensor **1401** may be located upstream of the mixing chamber **1405**. In this embodiment, the sensor **1401** may be configured to generate a signal representative of the quantity stored in one or more of the containers, of the rate of flow of one or more of the compounds, and or the like. The sensor **1401** may be located downstream of the vaporizing section **1404**. In this embodiment, the sensor **1401** may be configured to provide a signal representative of the rate of vaporization of the individual or combined compounds, and or the like. In other example embodiments, a sensor(s) may be located upstream of the mixing chamber **1405** and another sensor(s) may be located downstream

of the vaporizing section **1404**. Moreover, sensors may be located in any suitable position.

[001 34] The sensor(s) **1401** may be any suitable sensor. For example, the sensor(s) may sense particulates, vapor pressure, vapor content, temperature, volume, weight, container fill level, composition of the air, specific ingredient concentrations, flow rate of a fluid, density, sound, light, and or the like. The signal may be representative of the delivery of the one or more compounds. The signal may be interpreted by the processor **1407** that receives it for feedback control of the vaporizer.

[001 35] The processor **1407** may be coupled electronically to the vaporizing component(s) of vaporizing section **1404**. Processor **1407** may be configured to control the rate of vaporization for each vaporizing component it controls. In another embodiment, processor **1407** may be coupled electronically to the mechanisms controlling the flow rate of the respective compounds from the first container **1408** and the second container **1409**. Processor **1407** may use any suitable flow rate controller for controlling the rate of flow of the non-vaporizable material. Thus, processor **1407** may be configured to control the rate of flow of the vaporizable material and the non-vaporizable material, individually and/or collectively.

[001 36] Thus, in one embodiment, the processor **1407** may be coupled to a first vaporizing component and configured to control a first rate at which the first vaporizing component vaporizes the first vaporizable material **1530**; and the processor **1407** may be coupled to a flow control device configured to control a flow rate of the non-vaporizable material **1532**. The processor **1407** may control the first and/or second rates based on the signal(s) from the sensor(s). The processor **1407** is configured to adjust the content of the output vapor based on (1) the signal(s) from the sensor(s), and/or (2) data stored locally or external from hybrid vaporizer **1411**. The mixture and dosage controlled by the processor **1407** may be customized to the particular patient and/or patient's condition / health data.

[001 37] The output vapor may be controlled / varied based on the differences between the compounds, the mixture of the compounds, the concentration of the compounds, and/or the differences between the rate of vaporization / flow rate of the individual compounds or the mixed compounds, or other factors. Other factors may include, for example, time of day, date, user identifier, geographic location, or other input.

[001 38] In one example, the processor **1407** may use feedback from the sensors to increase the delivery rate of the compound(s). In another example embodiment, the sensor **1401** may sense a concentration level of a vaporized material that exceeds a threshold and send

a signal that may be used by the processor **1407** to reduce or stop the vaporization or that material. Thus, the separate sensors **1401** may provide separate feedback to a processor **1407** controlling the vaporizer such that the processor **1407** may derive data used to control the hybrid vaporizer **1411** to provide an exacting dose to a patient.

[00139] The processor **1407** may be configured to control hybrid vaporizer **1411** according to data received from an external source, e.g., a central server **1420**. The rate at which the hybrid vaporizer **1411** vaporizes the first compound or delivers the second compound may be controlled to one or more proscribed levels or times set by the user, a caregiver, a recommendation system, a social network or other third party. The hybrid vaporizer **1411** may include, in association with the processor **1407**, ancillary components such as a memory, battery or other power source **1406**, and input and output ports to the processor (not shown).

[00140] For example, a dosing regimen may be defined using by central server **1420** that causes the vapor distribution system **1400** to provide a measured amount of vaporized or nebulized material. The vaporization or nebulization of material may be programed for constant delivery or to provide varying amounts at different preprogrammed times. For example, a regimen may be prescribed to a person quitting smoking that gradually decreases the nicotine component delivered.

[00141] As the vaporization rate of a first substance is reduced or increased, one or more replacement substances may be consumed under control of the vaporizer's processor **1407** at a correspondingly increased or decreased rate to compensate for the change in rate of the first substance. Liquid ports may be used to admit different mixtures of multiple liquids to the mixing chamber **1405**, under control of the processor **1407**. Use of a particular vaporizable or non-vaporizable fluid may be locked or unlocked by one or more switches or valves, which may be controlled and/or configured as software, hardware, firmware, or some combination of the foregoing. Thus, the central processor **1420** may prevent an overdose, abuse of the compound, or mis-measuring of medicines.

[00142] The central server **1420** may be used to hold a user ID and to correlate that ID to a user's prescribed or desired conditions for utilizing the hybrid vaporizer **1411**. In another embodiment, the central server **1420** may be used to hold a room ID and to correlate that ID to a room's prescribed or desired conditions for utilizing the vaporization device. Control data may be provided to the hybrid vaporizer **1411** via a port or receiver in the hybrid vaporizer **1411**. A processor **1407** of the hybrid vaporizer **1411** receives the data

and may dispense or mix one or more available fluids in corresponding containers of the hybrid vaporizer **1411** to exact specifications as determined by the control data.

[00143] By tracking use of the hybrid vaporizer **1411** in association with a patient identifier at a remote server **1420**, a control scheme may be continued uninterrupted when the patient switches from one hybrid vaporizer **1411** to the next. For example, an associated control module may detect that a vapor regimen to a particular patient was stopped, by the patient changing vaporizers, before a particular control scheme was fulfilled. Accordingly, when the patient begins using the new hybrid vaporizer **1411**, the custom air treatment may continue uninterrupted. Thus, a dosing or use schedule may be maintained in a seamless way across any number of transitions between different vaporizers. A biometric component may utilize biometric data collected via input from the patient, the doctor, the nurses, the patient's records, and/or the like to track use by an identified user across multiple vaporizers or at the same vaporizer across various usages over time.

[00144] Hybrid vaporizer **1411** may collect usage data during use and transmit the data to a designated network address, for example an address for a central server **1420**. For example, the hybrid vaporizer **1411** may monitor levels of vaporizing fluids remaining in its internal reservoirs, using one or more sensors, and provide monitoring data to a data server via a wired or wireless port to a communication network. Usage data may be made available to the user, caregivers, loved ones and others in the users designated social network, by distribution from the data server, for example, using a data collection module. In this way a user or group of users may also be connected through their smart devices or via rudimentary interfaces on the vapor device to communicate with each other and receive notices about the care being provided to their loved one.

[00145] Moreover, the processor **1407** and/or central server **1420** facilitate the setting / specifying of a particular combination / proportion of the respective vaporizable material and non-vaporizable material. This setting / specifying can be performed by any suitable technique. For example, (1) the person who is using the device can provide an input directly to the device; or (2) the processor can look up a stored value reflecting a combination of vaporizable and non-vaporizable materials, wherein the stored value is associated with either the vaporizer or with the person using the vaporizer. In an example embodiment, the stored value is one of: a stored value custom created by the user, a stored value selected by the user from pre-set options, a stored value representing a

prescribed usage provided by a physician, and a stored value reflective of recommendations provided from a social network.

[00146] It should be appreciated that various different designs for vaporizing devices are known in the art and may be adapted for use with the technology disclosed herein by one of ordinary skill. In addition, similar portable and personal devices for nebulizing liquids to create a mist for inhalation to the lungs of a patient should be considered as generally encompassed within the meaning of "vaporizer" as used herein.

[00147] Referring to **FIG. 15**, alternative aspects of a system **1500** for remote access authorization or control of a vapor device are illustrated. The system **1500** may include an assembly **1502** for vaporizing a vaporizing fluid at a controlled rate, and for combining a first vaporized material with a second non-vaporized material in a controlled manner. The assembly **1502** includes at least one container **1522** holding a vaporizable material **1530**, sometimes referred to herein as a "first" container **1522** and "first" vaporizable material **1530**. In an aspect, the vaporizable material may be a fluid, such as a compressed gas, compressed liquid (e.g., a liquefied gas), or uncompressed liquid. Various suitable fluids are known in the art. In the alternative, or in addition, the first vaporizable material **1530** may be, or may include, a solid material. For embodiments using uncompressed liquids, the container **1522** may include a wick **1526** that carries the liquid to the vaporizing component **1520**. Although the wick **1526** is shown only in the center of the container **1522** for illustrative clarity, it should be appreciated that the wick **1526** may substantially fill the container **1522**. The container **1522** may be made of any suitable structural material, for example, an organic polymer, metal, ceramic, composite or glass material. Structural plastics may be preferred for disposable embodiments.

[00148] The assembly **1502** may further include at least one additional or "second" containers **1524** (one of potentially many shown). Container **1524** may be configured in any suitable manner for containing and delivering a non-vaporizable material (the second material **1532**) being contained. For example, if the first container **1522** contains a vaporizable oil, the second container **1524** may contain a nebulizable aqueous solution.

[00149] A vaporizer **1520** may be coupled to the first container **1522**. For example, coupling may be via a wick **1526**, via a valve, or by some other structure. The coupling mechanism may operate independently of gravity, such as by capillary action or pressure drop through a valve. The vaporizer **1520** is configured to vaporize the vaporizable material **1530** from the first container **1522** at a controlled rate; in operation, the vaporizer vaporizes a non-nebulizable material, producing an inhalable mist or component thereof.

In embodiments, the vaporizer may include a heater coupled to a wick **1526**, or a heated wick. A heating circuit may include a nickel-chromium wire or the like, with a temperature sensor (not shown) such as a thermistor or thermocouple. At minimum, control may be provided between no power (off state) and one or more powered states. Other control mechanisms may also be suitable.

[00150] A nebulizer **1521** may be coupled to the second container **1524**. For example, coupling may be via a tube **1528**, via a valve, wick, or some other structure. The coupling mechanism may operate independently of gravity, such as by capillary action or pressure drop through a valve. The nebulizer **1521** is configured to nebulize the non-vaporizable material **1532** from the second container **1524** at a controlled rate; in operation, the nebulizer **1521** nebulizes a non-vaporizable material, producing an inhalable mist or component thereof using a process distinct from the vaporizer **1520**. It bears repeating, however, that vaporizability and nebulizability should be assessed relative to specific input materials and defined processes. The rate may be controlled, for example, by varying an input pressure or velocity by controlling a pump speed or valve setting. At minimum, control may be provided between no power (off state) and one or more powered states. Other control mechanisms may also be suitable.

[00151] A processor **1508** is coupled to the vaporizer **1520** and nebulizer **1521** via an electrical circuit, configured to control a rate at which the vaporizer **1520** vaporizes the vaporizable material. In operation, the processor supplies a control signal to the vaporizer **1520** that controls the rate of vaporization. A receiver port **1512** is coupled to the processor, and the processor receives data determining the rate from the receiver port. Thus, the vaporization rate is remotely controllable, by providing the data. The processor **1508** may be, or may include, any suitable microprocessor or microcontroller, for example, a low-power application-specific controller (ASIC) designed for the task of controlling a vaporizer as described herein, or (less preferably) a general-purpose central processing unit, for example, one based on 80x86 architecture as designed by Intel™ or AMD™, or a system-on-a-chip as designed by ARM™. The processor **1508** may be communicatively coupled to auxiliary devices or modules of the assembly **1502**, using a bus or other coupling. Optionally, the processor **1508** and some or all of its coupled auxiliary devices or modules may be housed within or coupled to a housing **1504**, substantially enclosing the containers **1524**, **1524**, the vaporizer **1520**, the nebulizer **1521**, the processor **1508**, the receiver port **1512**, and other illustrated components. The assembly **1502** and housing **1504** may be configured together in any suitable form factor.

[001 52] In related aspects, the assembly **1502** includes a memory device **1506** coupled to the processor **1508**. The memory device **1506** may include a random access memory (RAM) holding program instructions and data for rapid execution or processing by the processor during control of the assembly **1502**. When the assembly **1502** is powered off or in an inactive state, program instructions and data may be stored in a long-term memory, for example, a non-volatile magnetic, optical, or electronic memory storage device, which is not separately shown. Either or both of the RAM or the storage device may comprise a non-transitory computer-readable medium holding program instructions, that when executed by the processor **1508**, cause the assembly **1502** to perform a method or operations as described herein. Program instructions may be written in any suitable high-level language, for example, C, C++, C#, or Java™, and compiled to produce machine-language code for execution by the processor. Program instructions may be grouped into functional modules, to facilitate coding efficiency and comprehensibility. It should be appreciated that such modules, even if discernable as divisions or grouping in source code, are not necessarily distinguishable as separate code blocks in machine-level coding. Code bundles directed toward a specific type of function may be considered to comprise a module, regardless of whether or not machine code on the bundle may be executed independently of other machine code. In other words, the modules may be high-level modules only.

[001 53] Although described herein with various components on board the assembly **1502**, it should be understood that some of these components, such as the processor **1508**, memory device **1506**, battery **1510**, and or the like, could be located somewhat remote from the vaporization device and or the functions performed by other devices.

[001 54] As mentioned above, the vaporizer may provide an output vapor to a specific room or area, or it may be custom to a particular patient. Thus, in a related aspect, the processor **1508** receives either a user identifier or a room identifier (identifier) and stores the identifier in the memory device **1506**. The identifier may include or be associated with user biometric data, that may be collected via input on a user input device, for example, a connected or communicatively coupled ancillary device **1538**, such as, for example, a smart phone executing a vaporizer interface application. In other embodiments, the identifier may be received from a sensor or a database, or from any other suitable source. The processor **1508** may generate data indicating a quantity of the vaporizable material **1530** consumed by the vaporizer **1520** in a defined period of time, or the non-vaporizable material **1532** consumed by the nebulizer **1521**, and save the data in

the memory device **1506**. The processor **1508** and other electronic components may be powered by a suitable battery **1510**, as known in the art, or other power source.

[001 55] The assembly **1502** may include a sensor **1516**, or multiple sensors **1516**, **1518**, to provide measurement feedback to the processor. For example, a sensor **1516** may be positioned downstream of the vaporizer, and the processor may derive the data used for controlling vaporization rate at least in part by interpreting a signal from the sensor correlated to a quantity of vapor emitted by the vaporizer. For further example, a sensor **1518** positioned upstream of the vaporizer, and the processor may derive the data at least in part by interpreting a signal from the sensor correlated to an amount of the vaporizable material remaining in the container, or to an amount of the vaporizable material passed from the container to the vaporizer, or both. "Downstream" and "upstream" relate to the direction of air flow or air/vapor mixture flow through the assembly **1502**, as illustrated by discharge arrow **1534** and inlet **1536**. Sensors **1516**, **1518** may include, for example, optical sensors, temperature sensors, motion sensors, flow speed sensors, microphones or other sensing devices.

[001 56] In related aspects, the assembly **1502** may include a transmitter port **1514** coupled to the processor. The memory device **1506** may hold a designated network address, and the processor **1508** may provide data indicating the quantity of the vaporizable material consumed by the vaporizer to the designated network address in association with the identifier, via the transmitter port **1514**.

[001 57] An ancillary device **1538**, such as a smartphone **1538**, tablet computer, administrator computer, nurse or doctor computer, or similar device, may be coupled to the transmitter port **1514** via a wired or wireless coupling. For example, the assembly **1502** may include a serial port, for example a universal serial bus (USB) port, coupled to receiver and transmitter inputs to the processor **1508**. In the alternative, or in addition, a wireless port (not shown) using Wifi (IEEE 802.11), Bluetooth, infrared, or other wireless standard may be coupled to the processor **1508**. The ancillary device **1538** may be coupled to the processor **1508** for providing user control input to vaporizer control process operated executing on the processor **1508**. User control input may include, for example, selections from a graphical user interface or other input (e.g., textual or directional commands) generated via a touch screen, keyboard, pointing device, microphone, motion sensor, camera, or some combination of these or other input devices, which may be incorporated in the ancillary device **1538**. A display **1539** of the ancillary device **1538** may be coupled to the processor **1407**, for example via a graphics processing

unit (not shown) integrated in the ancillary device **1538**. The display **1539** may include, for example, a flat screen color liquid crystal (LCD) display illuminated by light-emitting diodes (LEDs) or other lamps, a projector driven by an LED display or by a digital light processing (DLP) unit, a monitor, or other digital display device. User interface output driven by the processor **1508** may be provided to the display device **1539** and output as a graphical display to the user (or readout). Similarly, an amplifier/speaker or other audio output transducer of the ancillary device **1538** may be coupled to the processor **1508** via an audio processing system. Audio output correlated to the graphical output and generated by the processor **1508** in conjunction with the ancillary device **1538** may be provided to the audio transducer and output as audible sound.

[001 58] The ancillary device **1538** may be communicatively coupled via an access point **1540** of a wireless telephone network, local area network (LAN) or other coupling to a wide area network (WAN) **1544**, for example, the Internet. A server **1542** may be coupled to the WAN **1544** and to a database **1548** or other data store, and communicate with the assembly **1502** via the wan **1544** and display device **1539**. In alternative embodiments, functions of the ancillary device **1538** may be built directly into the assembly **1502**, if desired. Conversely, functions of the assembly **1502** may be built directly into the server or the ancillary device **1538** to provide remote control of the hybrid vaporizer.

[001 59] In related aspects, the processor **1508** may receive a request for replenishing the vaporizable material **1530** in the container **1522** via at least one of the receiver **1512** or a user input port coupled to the processor **1508**. For example, the assembly **1502** may include a user input device coupled to the receiver port **1512**. The processor **1508** may be configured to send the request to a designated network address stored in the memory device **1506** in association with the user identifier, via the transmitter port **1514**. For example, the processor **1508** may send the request to a commerce server **1542**, or to a server hosted by a medical or other service provider. Accordingly, the processor **1508** may facilitate keeping track of medication provided through assembly **1502**. In another aspect, an inlet port may be coupled to the container **1522** configured to admit the vaporizable material **1530** into the container **1522**. A similar process may be used to replenish the non-vaporizable material **1532**.

[001 60] The described technology may enable users to remotely access and authorize activation of a vaporization device, in one or more transactions with a supplier or medical provider. The transactions may be based at least in part on measurements of vaporizable material and/or non-vaporizable material consumed at a vaporization device identified

with a specific user or based at least in part on vaporizable/non-vaporizable material levels sensed in a room (or other sensor signals). In an example embodiment, the system **1400** may be configured to "call for service" if the materials are still in good supply, but the output vapor does not have the desired concentration of material. The transactions may enable replenishment of a supply of a vaporizable material. System **1400** may be configured to allow an authorized person to unlock permission to vaporize the material at a vaporizing device. This may be useful for ordinary commercial transaction, enforcing medically-based dose regimens, or other applications. Potency of the vaporized material may be controlled by selectively vaporizing contents of container **1522** and providing the contents of container **1524** to avoid accidental over consumption of an active substance.

[00161] **FIG. 16** is a block diagram illustrating components of an apparatus or system **1600** for controlling a vaporizer based on parameter data that provides a customized vaporization rate, in accord with the foregoing examples. The apparatus or system **1600** may include additional or more detailed components as described herein. For example, the processor **1610** and memory **1616** may contain an instantiation of a controller for a vaporizer or nebulizer as described herein above, including more detailed components as described herein, and other ancillary components. As depicted, the apparatus or system **1600** may include functional blocks that may represent functions implemented by a processor, software, or combination thereof (e.g., firmware).

[00162] As illustrated in **FIG. 16**, the apparatus or system **1600** may comprise an electrical component **1602** for controlling a rate at which a vaporizer vaporizes a vaporizable material, based on variable data specifying the rate. The component **1602** may be, or may include, a means for controlling a rate at which a vaporizer vaporizes a vaporizable material, based on variable data specifying the rate. Said means may include the processor **1610** coupled to the memory **1616**, and to the network interface **1614** and fluid dispenser (e.g., a heat-driven vaporizer), the processor executing an algorithm based on program instructions stored in the memory. Such algorithm may include a sequence of more detailed operations.

[00163] The apparatus or system **1600** may further comprise an electrical component **1604** for receiving or obtaining the variable data specifying the data rate from a data source that is external to the electronic vaporizer. "Specifying the rate" may include any one or more of defining a vaporization rate, defining control parameters known to achieve a specific rate, or defining one or more parameters used to determine an output of a rate-control algorithm. The component **1604** may be, or may include, a means for receiving or

obtaining the variable data specifying the data rate from a data source that is external to the electronic vaporizer. Said means may include the processor **1610** coupled to the memory **1616**, and to the network interface **1614**, the processor executing an algorithm based on program instructions stored in the memory. Such algorithm may include a sequence of more detailed operations, for example, retrieving a network address from the memory **1616**, sending a query requesting the data to a network address, and receiving a transmission including the requested data from a server at the network address. In the alternative, or in addition, such algorithm may include receiving a data broadcast or unicast message including the data from the server or from a coupled ancillary device, without the broadcast or unicast message being preceded by a data request. For example, a server may transmit vaporization control parameters periodically or automatically as part of a device initiation process.

[001 64] The apparatus **1600** may include a processor module **1610** having at least one processor, in the case of the apparatus **1600** configured as a controller configured to operate a fluid dispenser **1618** and other components of the apparatus. The processor **1610**, in such case, may be in operative communication with the memory **1616**, interface **1614** or dispenser/vaporizer **1618** via a bus **1612** or similar communication coupling. The processor **1610** may effect initiation and scheduling of the processes or functions performed by electrical components **1602-1604**.

[001 65] In related aspects, the apparatus **1600** may include a network interface module operable for communicating with a server over a computer network. The apparatus may include a controllable dispenser **1618** for a vaporizable material, for example, a heat-driven vaporizer for which vaporization rate is correlated to power supplied, or a micro-valve for which vaporization is proportional to valve position. In further related aspects, the apparatus **1600** may optionally include a module for storing information, such as, for example, a memory device/module **1616**. The computer readable medium or the memory module **1616** may be operatively coupled to the other components of the apparatus **1600** via the bus **1612** or the like. The memory module **1616** may be adapted to store computer readable instructions and data for enabling the processes and behavior of the modules **1602-1604**, and subcomponents thereof, or of the method **1800** and one or more of the additional operations disclosed herein. The memory module **1616** may retain instructions for executing functions associated with the modules **1602-1604**. While shown as being external to the memory **1616**, it is to be understood that the modules **1602-1604** may exist within the memory **1616**.

[001 66] An example of a control algorithm **1700** is illustrated by **FIG. 17**, for execution by a processor of a hybrid vaporizer **1411** as described herein, which includes independently controllable vaporization of a vaporizable material as well as providing of a non-vaporizable material. In the illustrated example, one of the materials is active, and it is desired to control the dose based on time, user mass, or any other desired criteria. The other material is inert, and any amount may be consumed. A ratio of 1 (one) indicates that 100% of the vapor produced is the active material. A ratio of 0 (zero) indicates that none of the vapor is active material, and hence 100% is the inert material. Intermediate ratios are possible, and may be desirable, to avoid abrupt changes in dose administration. The ratio may be controlled by allocating power to independent vaporization heaters allocated to the respective materials to be vaporized. Moreover, in other embodiments, the first material and the second material may both be active or both inactive.

[001 67] The algorithm **1700** may be triggered by activation of the device at **1752**, for example when a user takes an initial puff. Puffs taken before the control algorithm is operative may be controlled at a zero ratio, or 100% inert material. At **1754**, the processor initiates a current vaporization ratio, based on locally stored and/or remotely obtained data **1756**, including user identifier, past use records, the applicable control scheme, and any relevant criteria. For example, for a new user with no past use and a target dose well above that which may be achieved by a single puff, the processor may set the ratio equal to one. At **1758**, the processor waits for the next puff, for example, by executing a wait loop.

[001 68] Once a puff is detected at **1762**, the processor estimates a puff volume and potency based on open loop data (e.g., the set ratio, known materials, and vaporization power), on feedback data (e.g., vapor opacity, flow rate, time), or some combination of open loop and feedback data, and from this calculates, at **1764**, an incremental dose. At **1766**, the processor determines whether a cumulative dose is approaching any limit that calls for reduction of the vaporization ratio to avoid an excess dose. This may be a simple "on" until exceeded, then "off" control scheme, or may be a form of more sophisticated control such as, for example, proportional control, proportional-integral (PI) control, or proportional-integral-derivative (PID) control. If real-time dose level from blood sensing or similar data is available, control may be benchmarked by a measured current dose. If actual dose measurements are not available, the dose may be estimated based on vaporization and puff data. If a reduction in dose is called for, the processor may reduce the control ratio by a calculated amount, at **1768**. For example, in a proportional control

scheme, the controller may reduce the ratio by an amount proportional to the estimated cumulative dose level relative to the targeted dose level. As the estimated cumulative dose approaches the target, therefore, the rate of reduction may increase.

[001 69] If no reduction is called for at **1766**, or no puff is detected at **1762**, the processor may determine, at **1760**, whether the device has been inactive long enough trigger deactivation. If time is not elapsed, the processor may re-enter the wait loop **1758**. If time is elapsed, the processor may initiate a deactivation sequence at **1770**. The deactivation sequence **1770** may include, for example, storing a current time stamp and cumulative dose information in a data record **1772**, which may be stored locally, and or remotely. Then, the processor may power off or enter a low-power "sleep" mode **1774**.

[001 70] In view the foregoing, and by way of additional example, **FIG. 18**, **FIG. 19**, and **FIG. 20** show aspects of a method or methods for controlling a vaporizer, as may be performed by a vaporizing device as described herein, alone or in combination with other elements of the systems and apparatuses disclosed herein. Referring to **FIG. 18**, the method **1800** may include, at **1810**, activating electronic vaporizer that includes a container for holding a vaporizable material, a container for holding a non-vaporizable material, a vaporizer coupled to the container for vaporizing the vaporizable material, and a processor. For example, a user input, such as a puff, or timer or other control signal may send an activation interrupt to a sleeping processor, which in response to the interrupt may power up the control circuitry of the vaporizer and begin an initialization sequence.

[001 71] The method **1800** may further include, at **1820**, controlling, by the processor, a rate at which the vaporizer vaporizes the vaporizable material, based on data specifying the rate. For example, the data may specify a user identifier, room identifier, cumulative dose information with timestamp, and a metabolic decay profile for the user/room and applicable substance(s) to be vaporized. From this, the processor may calculate a ratio or other value that controls the rate at which the vaporizable material is vaporized. The vaporized material can then be provided, in an inhalable form, to the person along with the non-vaporizable material(s).

[001 72] The method **1800** may further include, at **1830**, receiving the data specifying the rate from a data source external to the electronic vaporizer. For example, the processor may at any time prior to the operation **1820**, receive data from a connected smartphone, nurse or doctor computer, or the like that sets a target dosing profile for one or more identified users/rooms. In the alternative, or in addition, the processor may receive data used in controlling vaporization during or after a control operation.

[001 73] Moreover, the method **1800** may further include setting a proportion of vaporizable to non-vaporizable materials. The setting the proportion of the vaporizable to non-vaporizable materials may be performed by: the person using the hybrid vaporizer providing an input directly to the device; or by the processor looking up a stored value reflecting a combination of vaporizable and non-vaporizable materials, wherein the stored value is associated with either the vaporizer or with the person using the vaporizer. In an example embodiment, the stored value is one of: a stored value custom created by the user, a stored value selected by the user from pre-set options, a stored value representing a prescribed usage provided by a physician, and a stored value reflective of recommendations provided from a social network. Thus, the hybrid vaporizer may be configured to automatically establish the mix of vaporized and non-vaporized materials provided to the user of the hybrid vaporizer.

[001 74] The method **1800** may include any one or more of additional operations **1900**, shown in **FIG. 19**, in any operable order. Each of these additional operations is not necessarily performed in every embodiment of the method, and the presence of any one of the operations does not necessarily require that any other of these additional operations also be performed.

[001 75] Referring to **FIG. 19** showing additional operations **1900**, the method **1800** may further include, at **1910**, receiving a user/room identifier and storing the user/room identifier in a memory component of the electronic vaporizer. A user identifier may optionally include biometric data.

[001 76] The method **1800** may include, at **1920**, generating data indicating a quantity of the vaporizable material consumed by the vaporizer in a defined period of time, and saving the data in the memory component. These data may include open-loop and/or sensor feedback data. For example, the method **1800** may include, at **1930**, deriving the data at least in part by interpreting a signal from a sensor downstream of the vaporizer correlated to a quantity of vapor emitted by the vaporizer. In addition, or in the alternative, the method **1800** may include, at **1940**, deriving the data at least in part by interpreting a signal from a sensor upstream of the vaporizer correlated to at least one of: an amount of the vaporizable material remaining in the container, or an amount of the vaporizable material passed from the container to the vaporizer. However the data is derived, the method may include, at **1950**, providing the data indicating the quantity of the vaporizable material consumed by the vaporizer to a designated network address stored in the memory component in association with the user/room identifier. For

example, the network address may be for a server operated by a medical provider or therapeutic consultant, who has a relationship with the identifier user. Transmitted data may be encrypted and secured using any suitable method.

[00177] An electronic vapor device is disclosed comprising a vapor outlet, a first container for storing a vaporizable material, a second container for storing a non-vaporizable material, a vaporizer component coupled to the first container configured for vaporizing the vaporizable material at a vaporization rate to generate a first vapor and for providing the first vapor to the vapor outlet, and a nebulizer component coupled to the second container configured for nebulizing the non-vaporizable material at a nebulization rate to generate a second vapor and for providing the second vapor to the vapor outlet. The vaporizer component and the nebulizer component vaporize the vaporizable material and nebulize the non-vaporizable material, respectively, in serial or simultaneously. The electronic vapor device can further comprise a mixing chamber coupled to the vaporizer component and the nebulizer component to receive the first vapor and the second vapor, to mix the first vapor and the second vapor and, to provide the mixed vapor to the vapor outlet. A composition of the mixed vapor can vary based on at least one of the vaporization rate and the nebulization rate. The electronic vapor device can be coupled to an electronic communication device such as a smartphone, a smart watch, a tablet, a laptop, and the like.

[00178] The electronic vapor device can further comprise a processor, configured for determining the vaporization rate and the nebulization rate and for providing the vaporization rate to the vaporizer component and the nebulization rate to the nebulizer component.

[00179] The processor can be further configured to independently control the vaporization rate and the nebulization rate. The electronic vapor device can further comprise a network access device, and wherein the processor can be further configured to receive the vaporization rate and the nebulization rate from a remote server via the network access device. The processor can be configured to receive data from the remote server indicating a medically prescribed dose of at least one of the vaporizable material and the non-vaporizable material and for determining the vaporization rate and the nebulization rate based on the data. The processor can be configured to receive data from the remote server indicating a formula for producing a specific flavor of vapor and for determining the vaporization rate and the nebulization rate based on the data. The processor can be configured to determine that a user of the electronic vapor device has access rights to the

formula. The processor can be further configured to adjust at least one of the vaporization rate and the nebulization rate during use of the electronic vapor device.

[00180] The electronic vapor device can further comprise an input device configured for receiving the vaporization rate and the nebulization rate. The input device can comprise one or more of, a touchscreen, a switch, a dial, a knob, a slider, or a button.

[00181] The vaporizer component can comprise a heating element for vaporizing the vaporizable material and the nebulizer component can comprise at least one of a vibrating mesh for nebulizing the non-vaporizable material into a mist, an atomizer for atomizing the non-vaporizable material into an aerosol, an ultrasonic nebulizer for nebulizing the non-vaporizable material into a mist, and a heating element for enhancing effectiveness of a nebulizing process.

[00182] Referring to **FIG. 20**, a method **2000** is disclosed comprising determining a vaporization rate and a nebulization rate at **2010**. Determining the vaporization rate and the nebulization rate can comprise determining a formula for the mixed vapor and determining the vaporization rate and the nebulization rate based on the formula. Determining the vaporization rate and the nebulization rate can comprise receiving data indicative of the vaporization rate and the nebulization rate from a remote server via a network access device. The data can indicate a medically prescribed dose of at least one of the vaporizable material and the non-vaporizable material and wherein the vaporization rate and the nebulization rate are determined based on the data.

[00183] The method **2000** can comprise vaporizing a vaporizable material based on the vaporization rate to create a first vapor at **2020**. The method **2000** can comprise nebulizing a non-vaporizable material based on the nebulization rate to create a second vapor at **2030**. Vaporizing the vaporizable material based on the vaporization rate to create the first vapor and nebulizing the non-vaporizable material based on the nebulization rate to create the second vapor are performed in serial or simultaneously.

[00184] The method **2000** can comprise mixing the first vapor and the second vapor to create a mixed vapor at **2040**. The method **2000** can comprise expelling the mixed vapor through an exhaust port at **2050**. Mixing the first vapor and the second vapor to create a mixed vapor can comprise receiving the first vapor and the second vapor into a mixing chamber to mix the first vapor and the second vapor and expelling the mixed vapor through the exhaust port for inhalation by a user.

[00185] The method **2000** can further comprise determining an amount of the vaporizable material based on the vaporization rate, determining an amount of the non-vaporizable

material based on the nebulization rate, withdrawing the amount of the vaporizable material into a vaporizer component for vaporization, and withdrawing the amount of the non-vaporizable material into a nebulizer component for vaporization.

[001 86] The method **2000** can further comprise determining a ratio of vaporizable material to non-vaporizable material and determining the vaporization rate and the nebulization rate based on the ratio.

[001 87] The methods disclosed may include any one or more of additional operations of any other method in any operable order. Each of these additional operations is not necessarily performed in every embodiment of the method, and the presence of any one operation does not necessarily require that any other additional operations also be performed.

[001 88] In view of the exemplary systems described supra, methodologies that can be implemented in accordance with the disclosed subject matter have been described with reference to several flow diagrams. While for purposes of simplicity of explanation, the methodologies are shown and described as a series of blocks, it is to be understood and appreciated that the claimed subject matter is not limited by the order of the blocks, as some blocks may occur in different orders and/or concurrently with other blocks from what is depicted and described herein. Moreover, not all illustrated blocks can be required to implement the methodologies described herein. Additionally, it should be further appreciated that the methodologies disclosed herein are capable of being stored on an article of manufacture to facilitate transporting and transferring such methodologies to computers.

[001 89] Those of skill would further appreciate that the various illustrative logical blocks, modules, circuits, and algorithm steps described in connection with the aspects disclosed herein can be implemented as electronic hardware, computer software, or combinations of both. To clearly illustrate this interchangeability of hardware and software, various illustrative components, blocks, modules, circuits, and steps have been described above generally in terms of their functionality. Whether such functionality is implemented as hardware or software depends upon the particular application and design constraints imposed on the overall system. Skilled artisans may implement the described functionality in varying ways for each particular application, but such implementation decisions should not be interpreted as causing a departure from the scope of the present disclosure.

[00190] As used in this application, the terms "component," "module," "system," and the like are intended to refer to a computer-related entity, either hardware, a combination of hardware and software, software, or software in execution. For example, a component can be, but is not limited to being, a process running on a processor, a processor, an object, an executable, a thread of execution, a program, and/or a computer. By way of illustration, both an application running on a server and the server can be a component. One or more components may reside within a process and/or thread of execution and a component can be localized on one computer and/or distributed between two or more computers.

[00191] As used herein, a "vapor" includes mixtures of a carrier gas or gaseous mixture (for example, air) with any one or more of a dissolved gas, suspended solid particles, or suspended liquid droplets, wherein a substantial fraction of the particles or droplets if present are characterized by an average diameter of not greater than three microns. As used herein, an "aerosol" has the same meaning as "vapor," except for requiring the presence of at least one of particles or droplets. A substantial fraction means 10% or greater; however, it should be appreciated that higher fractions of small (<3 micron) particles or droplets can be desirable, up to and including 100%. It should further be appreciated that, to simulate smoke, average particle or droplet size can be less than three microns, for example, can be less than one micron with particles or droplets distributed in the range of 0.01 to 1 micron. A vaporizer may include any device or assembly that produces a vapor or aerosol from a carrier gas or gaseous mixture and at least one vaporizable material. An aerosolizer is a species of vaporizer, and as such is included in the meaning of vaporizer as used herein, except where specifically disclaimed.

[00192] Various aspects presented in terms of systems can comprise a number of components, modules, and the like. It is to be understood and appreciated that the various systems may include additional components, modules, etc. and/or may not include all of the components, modules, etc. discussed in connection with the figures. A combination of these approaches can also be used.

[00193] In addition, the various illustrative logical blocks, modules, and circuits described in connection with certain aspects disclosed herein can be implemented or performed with a general purpose processor, a digital signal processor (DSP), an application specific integrated circuit (ASIC), a field programmable gate array (FPGA) or other programmable logic device, discrete gate or transistor logic, discrete hardware components, or any combination thereof designed to perform the functions described herein. A general purpose processor can be a microprocessor, but in the alternative, the

processor can be any conventional processor, controller, microcontroller, system-on-a-chip, or state machine. A processor may also be implemented as a combination of computing devices, e.g., a combination of a DSP and a microprocessor, a plurality of microprocessors, one or more microprocessors in conjunction with a DSP core, or any other such configuration.

[00194] Operational aspects disclosed herein can be embodied directly in hardware, in a software module executed by a processor, or in a combination of the two. A software module may reside in RAM memory, flash memory, ROM memory, EPROM memory, EEPROM memory, registers, hard disk, a removable disk, a CD-ROM, a DVD disk, or any other form of storage medium known in the art. An exemplary storage medium is coupled to the processor such the processor can read information from, and write information to, the storage medium. In the alternative, the storage medium can be integral to the processor. The processor and the storage medium may reside in an ASIC or may reside as discrete components in another device.

[00195] Furthermore, the one or more versions can be implemented as a method, apparatus, or article of manufacture using standard programming and/or engineering techniques to produce software, firmware, hardware, or any combination thereof to control a computer to implement the disclosed aspects. Non-transitory computer readable media can include but are not limited to magnetic storage devices (e.g., hard disk, floppy disk, magnetic strips...), optical disks (e.g., compact disk (CD), digital versatile disk (DVD)...), smart cards, and flash memory devices (e.g., card, stick). Those skilled in the art will recognize many modifications can be made to this configuration without departing from the scope of the disclosed aspects.

[00196] The previous description of the disclosed aspects is provided to enable any person skilled in the art to make or use the present disclosure. Various modifications to these aspects will be readily apparent to those skilled in the art, and the generic principles defined herein can be applied to other embodiments without departing from the spirit or scope of the disclosure. Thus, the present disclosure is not intended to be limited to the embodiments shown herein but is to be accorded the widest scope consistent with the principles and novel features disclosed herein.

[00197] Unless otherwise expressly stated, it is in no way intended that any method set forth herein be construed as requiring that its steps be performed in a specific order. Accordingly, where a method claim does not actually recite an order to be followed by its steps or it is not otherwise specifically stated in the claims or descriptions that the steps

are to be limited to a specific order, it is in no way intended that an order be inferred, in any respect. This holds for any possible non-express basis for interpretation, including: matters of logic with respect to arrangement of steps or operational flow; plain meaning derived from grammatical organization or punctuation; the number or type of embodiments described in the specification.

[00198] It will be apparent to those skilled in the art that various modifications and variations can be made without departing from the scope or spirit. Other embodiments will be apparent to those skilled in the art from consideration of the specification and practice disclosed herein. It is intended that the specification and examples be considered as exemplary only, with a true scope and spirit being indicated by the following claims.

CLAIMS

1. An electronic vapor device comprising:
a vapor outlet;
a first container for storing a vaporizable material;
a second container for storing a non-vaporizable material;
a vaporizer component coupled to the first container configured for vaporizing the vaporizable material at a vaporization rate to generate a first vapor and for providing the first vapor to the vapor outlet; and
a nebulizer component coupled to the second container configured for nebulizing the non-vaporizable material at a nebulization rate to generate a second vapor and for providing the second vapor to the vapor outlet.
2. The electronic vapor device of claim 1, wherein the vaporizer component and the nebulizer component vaporize the vaporizable material and nebulize the non-vaporizable material, respectively, in serial or simultaneously.
3. The electronic vapor device of claim 1, further comprising a mixing chamber coupled to the vaporizer component and the nebulizer component to receive the first vapor and the second vapor, to mix the first vapor and the second vapor and, to provide the mixed vapor to the vapor outlet.
4. The electronic vapor device of claim 3, wherein a composition of the mixed vapor varies based on at least one of the vaporization rate and the nebulization rate.
5. The electronic vapor device of claim 1, further comprising a processor, configured for determining the vaporization rate and the nebulization rate and for providing the vaporization rate to the vaporizer component and the nebulization rate to the nebulizer component.
6. The electronic vapor device of claim 5, wherein the processor is further configured to independently control the vaporization rate and the nebulization rate.
7. The electronic vapor device of claim 5, further comprising a network access device, and wherein the processor is further configured to receive the vaporization rate and the nebulization rate from a remote server via the network access device.

8. The electronic vapor device of claim 5, wherein the processor is configured to receive data from the remote server indicating a medically prescribed dose of at least one of the vaporizable material and the non-vaporizable material and for determining the vaporization rate and the nebulization rate based on the data.

9. The electronic vapor device of claim 5, wherein the processor is configured to receive data from the remote server indicating a formula for producing a specific flavor of vapor and for determining the vaporization rate and the nebulization rate based on the data.

10. The electronic vapor device of claim 9, wherein the processor is configured to determine that a user of the electronic vapor device has access rights to the formula.

11. The electronic vapor device of claim 5, wherein the processor is further configured to adjust at least one of the vaporization rate and the nebulization rate during use of the electronic vapor device.

12. The electronic vapor device of claim 1, further comprising an input device configured for receiving the vaporization rate and the nebulization rate.

13. The electronic vapor device of claim 12, wherein the input device comprises one or more of, a touchscreen, a switch, a dial, a knob, a slider, or a button.

14. The electronic vapor device of claim 1, wherein the vaporizer component comprises a heating element for vaporizing the vaporizable material and the nebulizer component comprises at least one of a vibrating mesh for nebulizing the non-vaporizable material into a mist, an atomizer for atomizing the non-vaporizable material into an aerosol, an ultrasonic nebulizer for nebulizing the non-vaporizable material into a mist, and a heating element for enhancing effectiveness of a nebulizing process.

15. The electronic vapor device of claim 1, wherein the electronic vapor device is coupled to an electronic communication device.

16. A method comprising:
determining a vaporization rate and a nebulization rate;

vaporizing a vaporizable material based on the vaporization rate to create a first vapor;
nebulizing a non-vaporizable material based on the nebulization rate to create a second vapor;
mixing the first vapor and the second vapor to create a mixed vapor; and
expelling the mixed vapor through an exhaust port.

17. The method of claim 14, further comprising:
determining an amount of the vaporizable material based on the vaporization rate;
determining an amount of the non-vaporizable material based on the nebulization rate;
withdrawing the amount of the vaporizable material into a vaporizer component for vaporization; and
withdrawing the amount of the non-vaporizable material into a nebulizer component for vaporization.

18. The method of claim 14, wherein determining the vaporization rate and the nebulization rate comprises:
determining a formula for the mixed vapor; and
determining the vaporization rate and the nebulization rate based on the formula.

19. The method of claim 14, wherein vaporizing the vaporizable material based on the vaporization rate to create the first vapor and nebulizing the non-vaporizable material based on the nebulization rate to create the second vapor are performed in serial or simultaneously.

20. The method of claim 14, wherein mixing the first vapor and the second vapor to create a mixed vapor comprises:

receiving the first vapor and the second vapor into a mixing chamber to mix the first vapor and the second vapor; and
expelling the mixed vapor through the exhaust port for inhalation by a user.

21. The method of claim 14, wherein determining the vaporization rate and the nebulization rate comprises receiving data indicative of the vaporization rate and the nebulization rate from a remote server via a network access device.

22. The method of claim 14, wherein the data indicates a medically prescribed dose of at least one of the vaporizable material and the non-vaporizable material and wherein the vaporization rate and the nebulization rate are determined based on the data.

23. The method of claim 14, further comprising:
determining a ratio of vaporizable material to non-vaporizable material; and
determining the vaporization rate and the nebulization rate based on the ratio.

FIG. 1

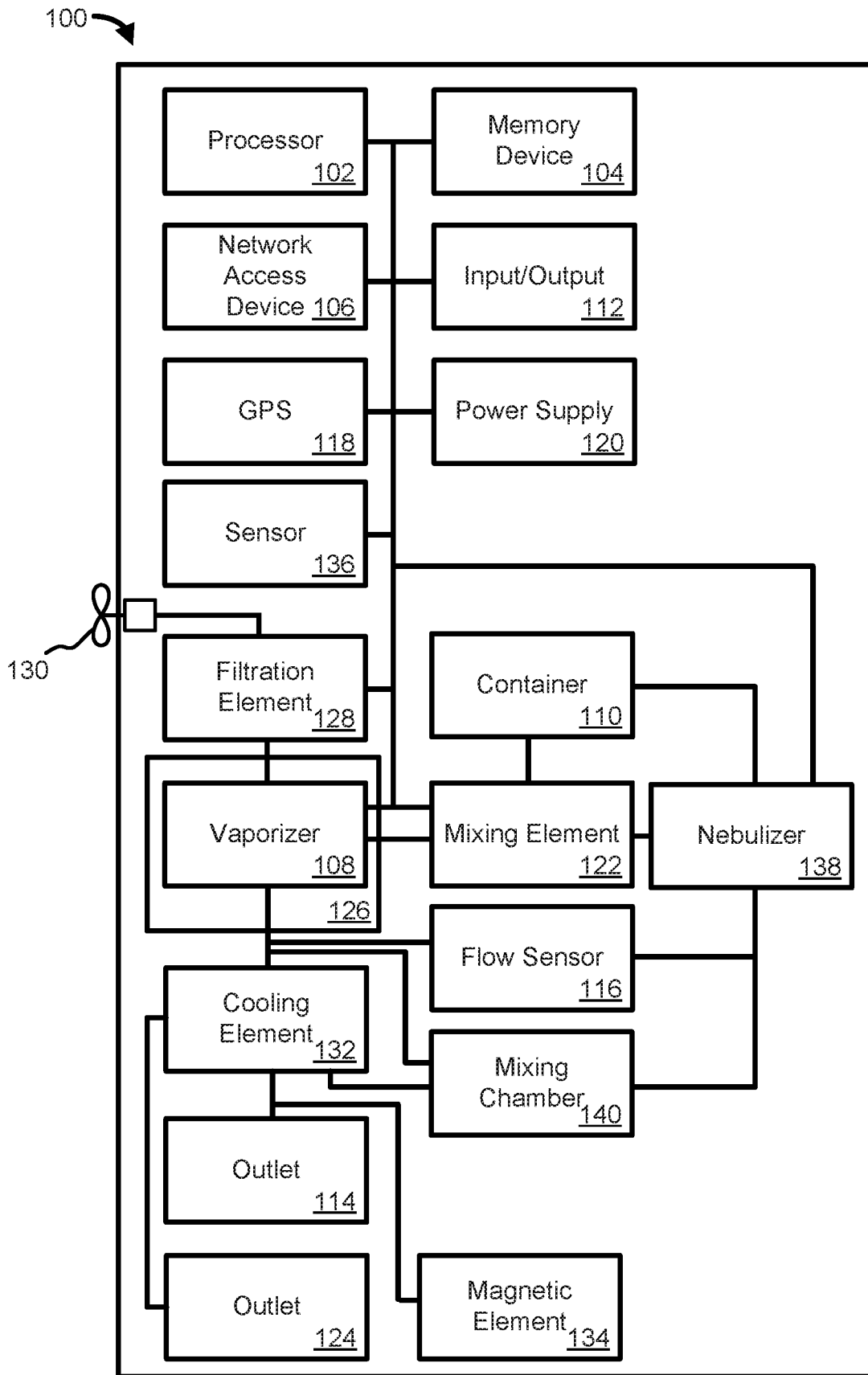

FIG. 2

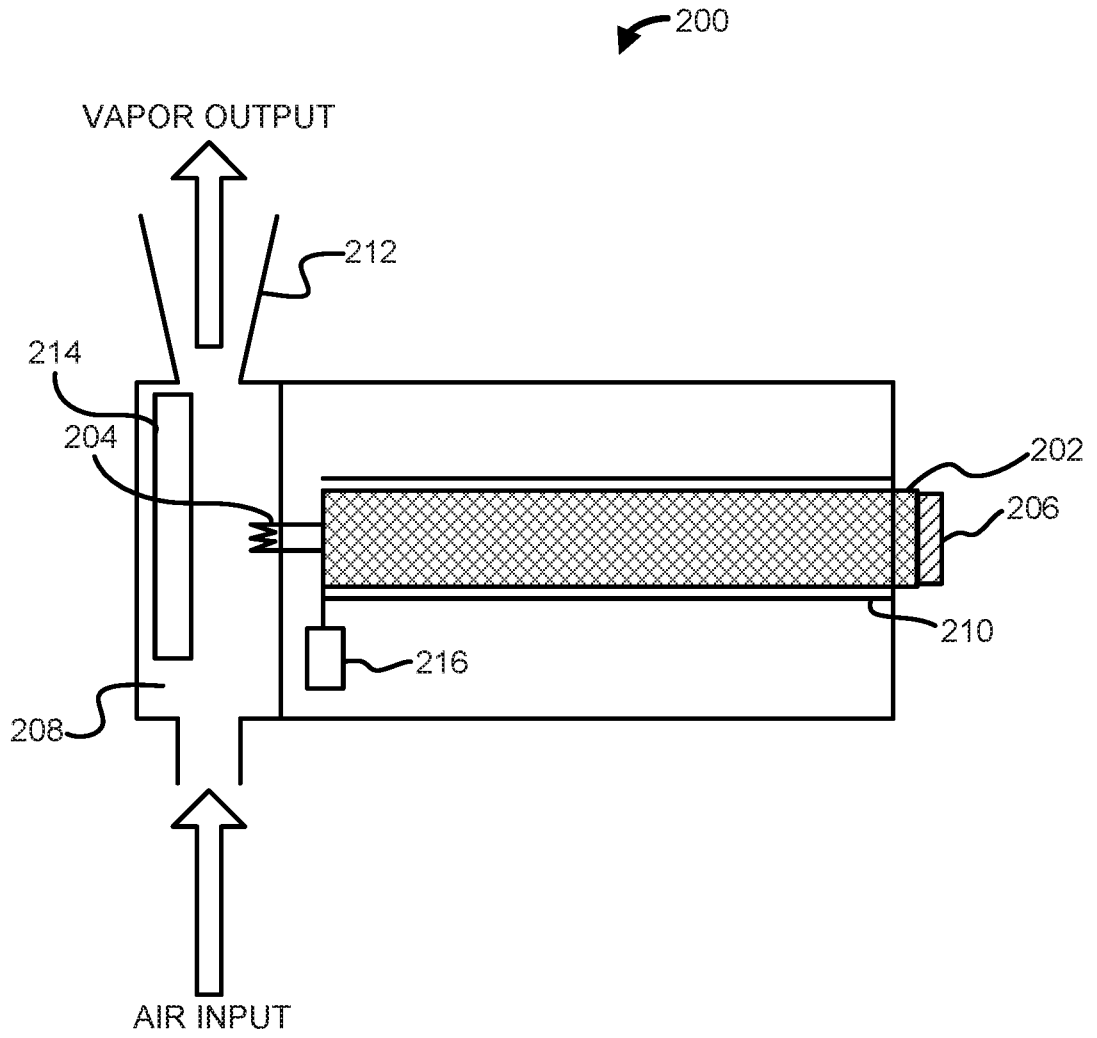

FIG. 3

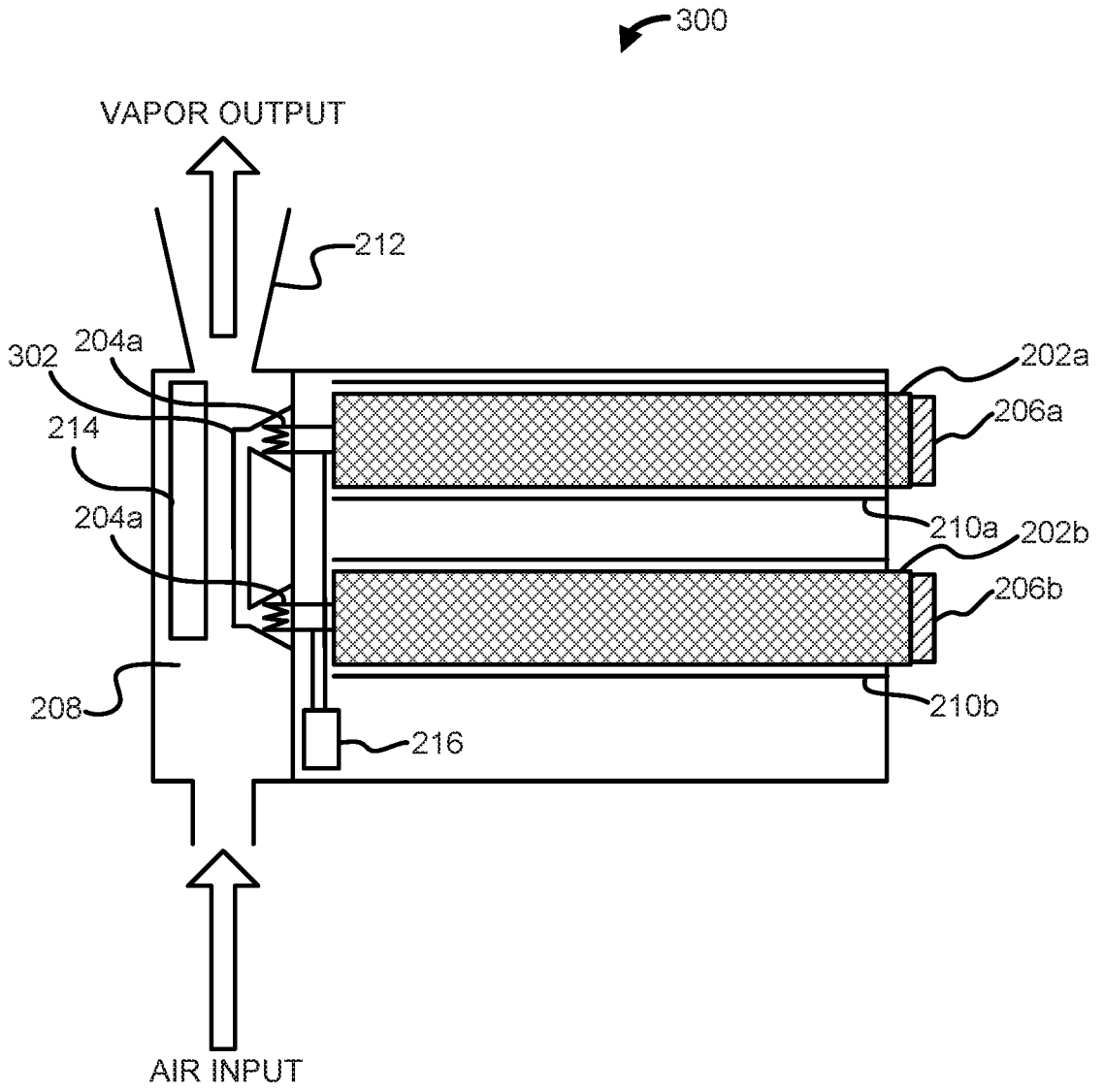

FIG. 4

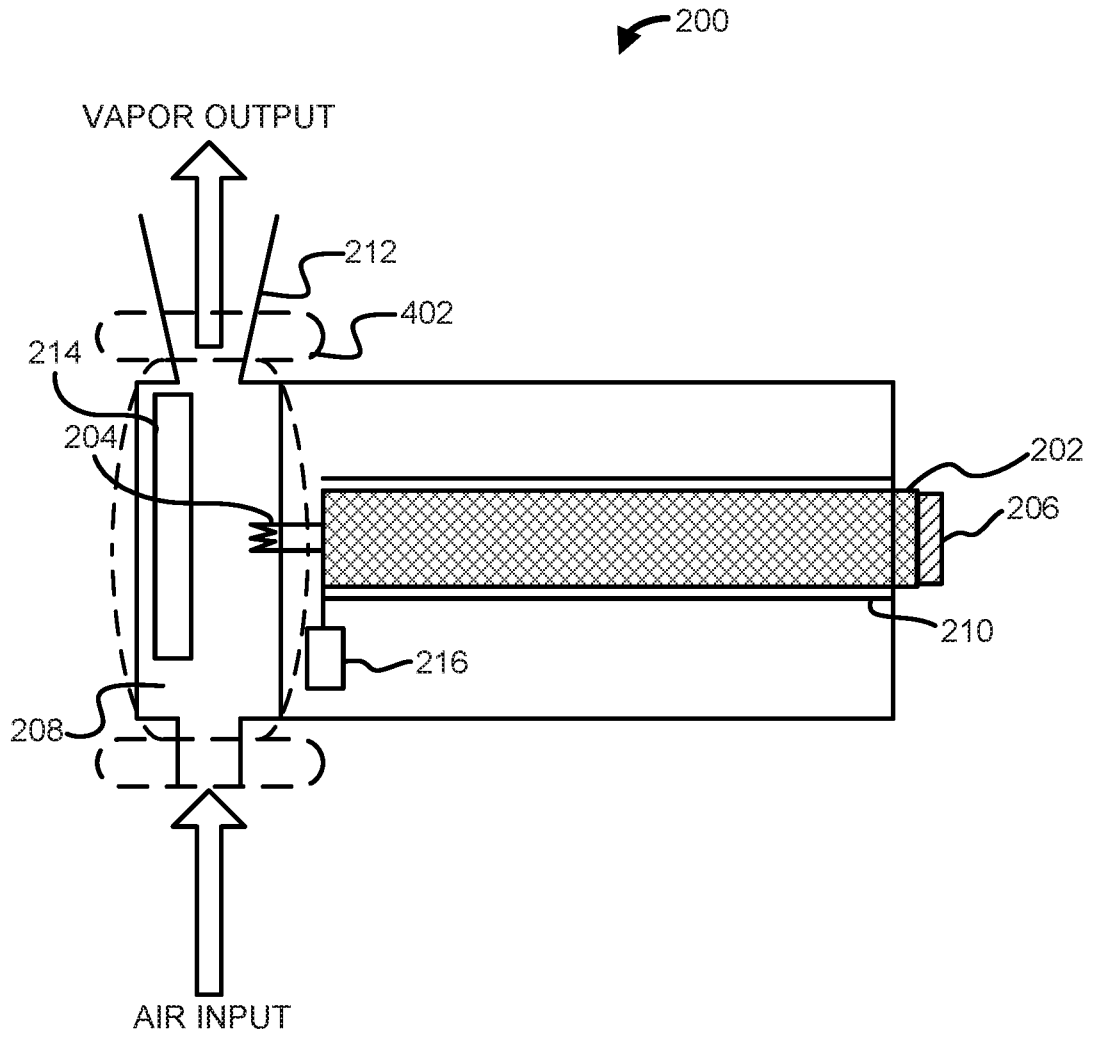

FIG. 5

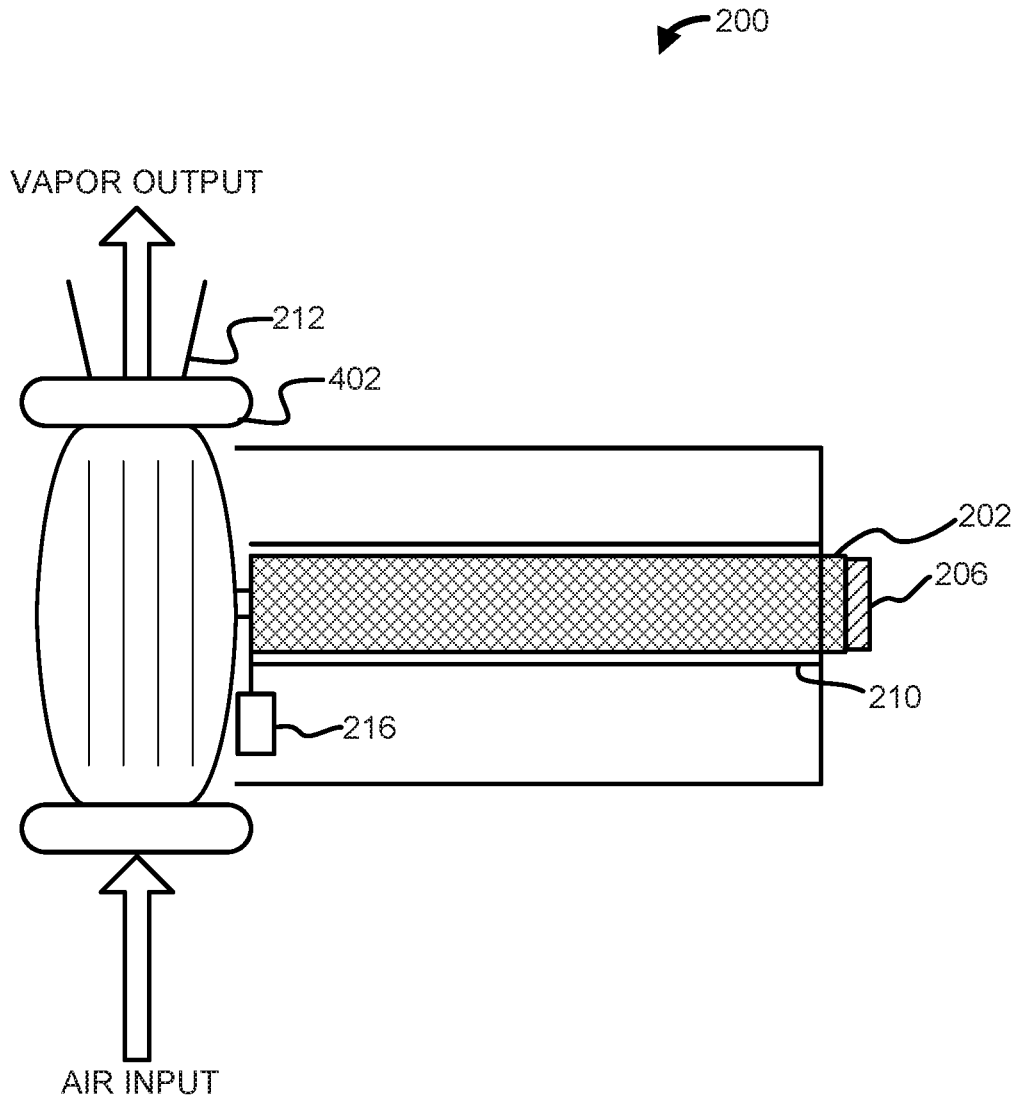

FIG. 6

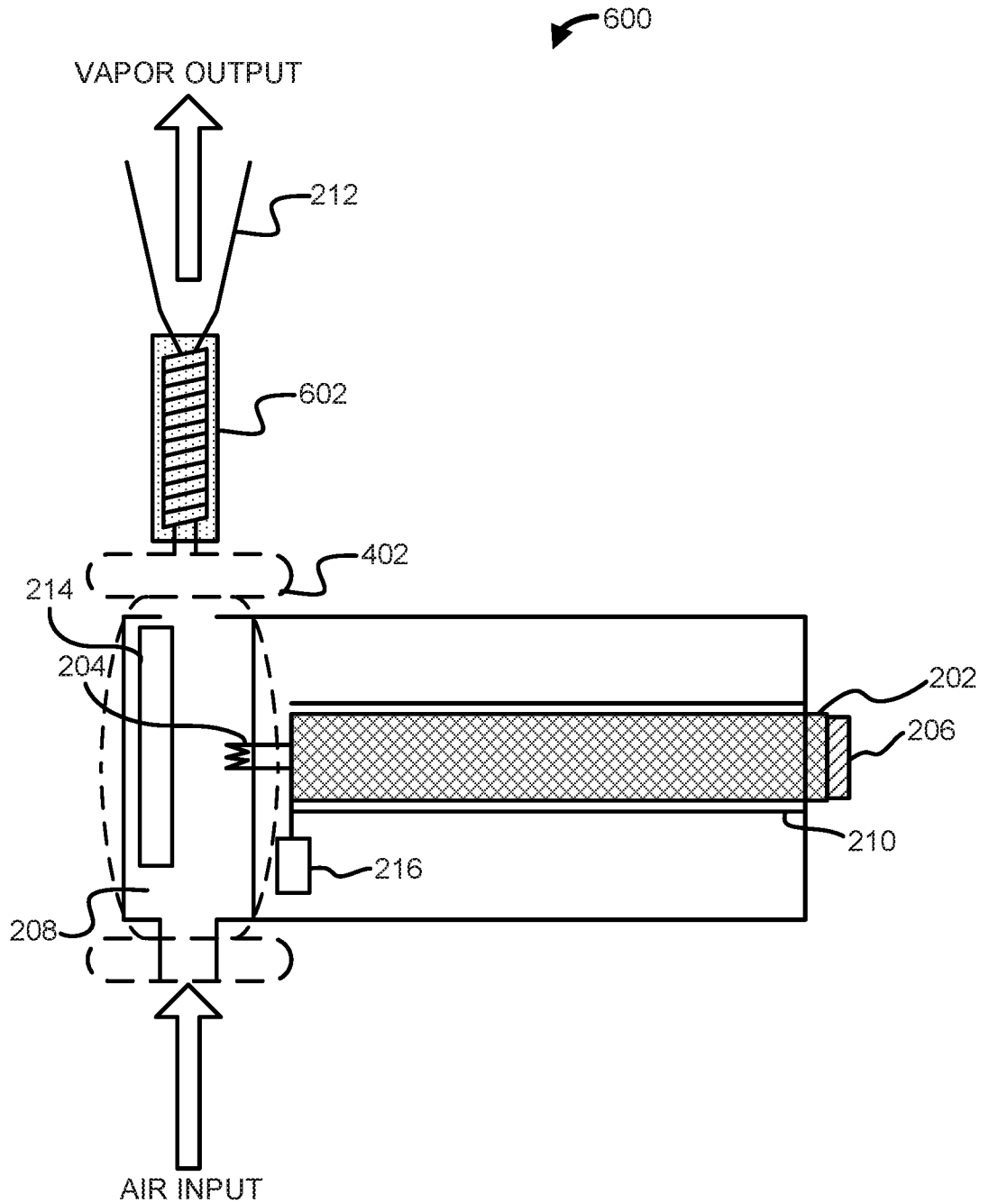

FIG. 7

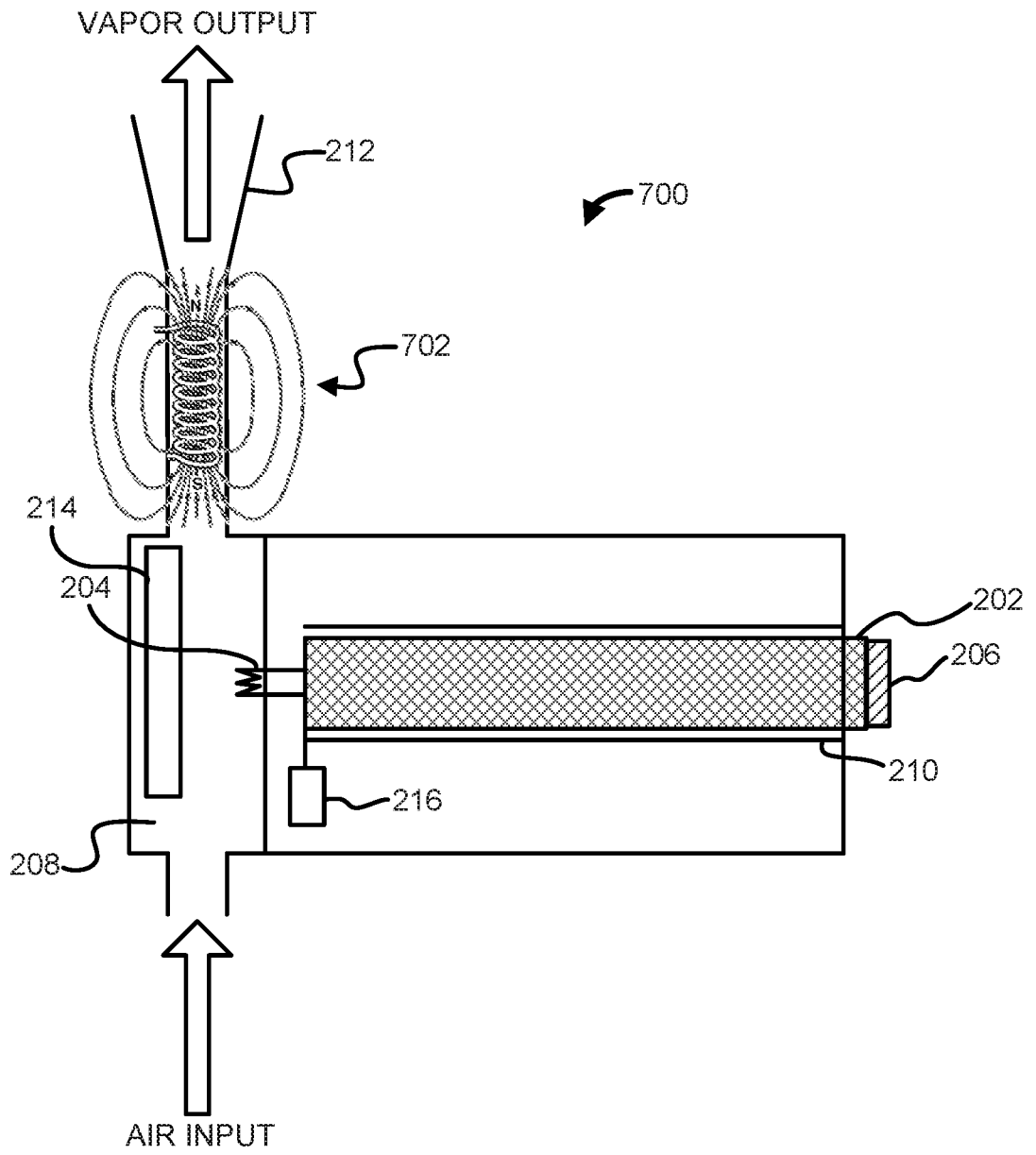

FIG. 8

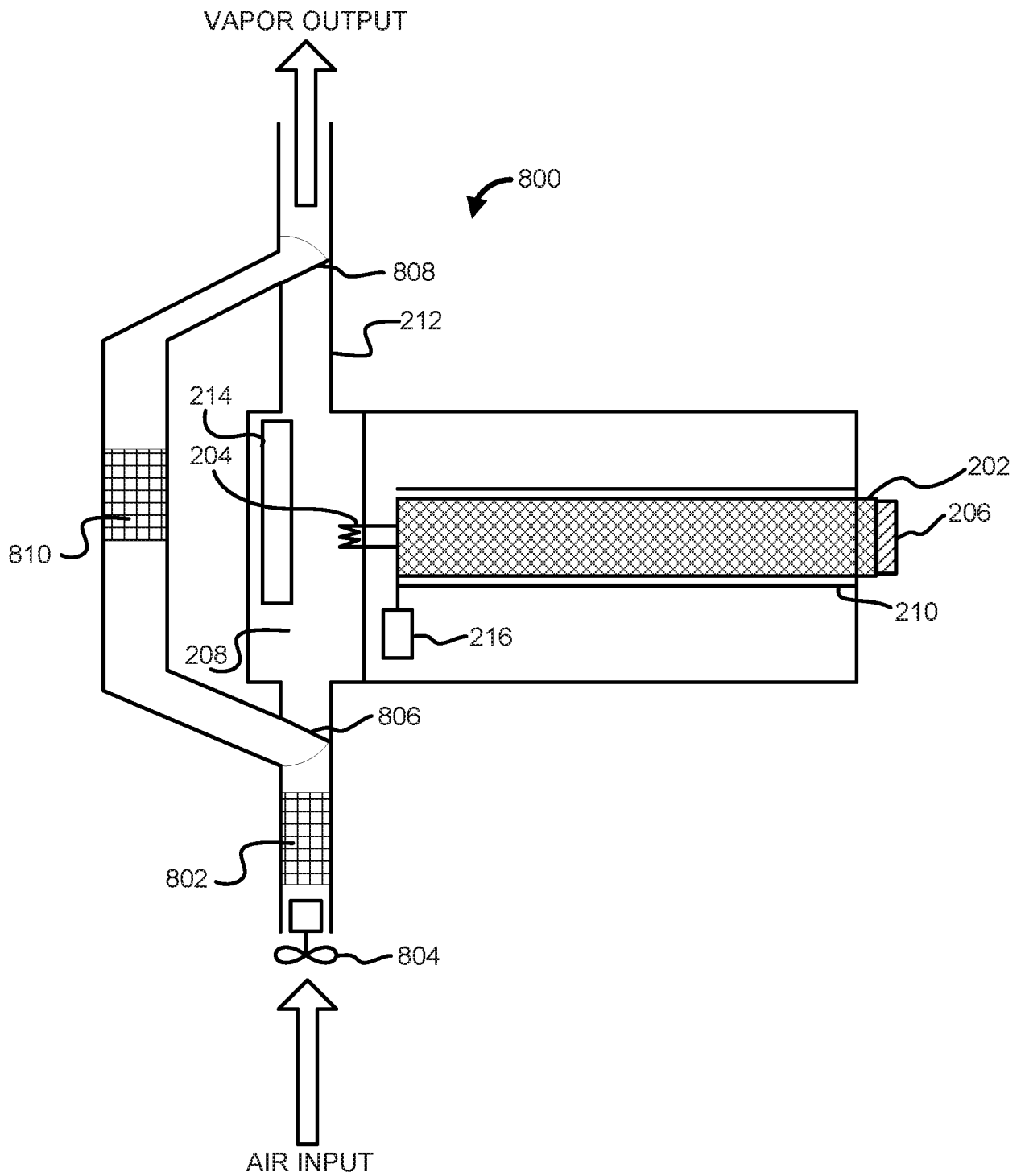

FIG. 9

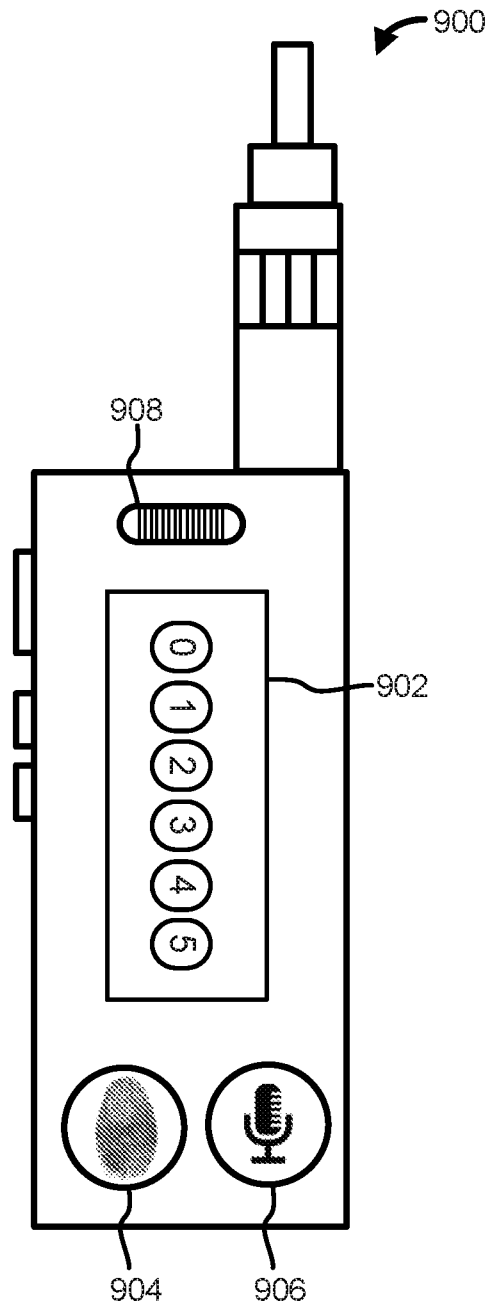

FIG. 10

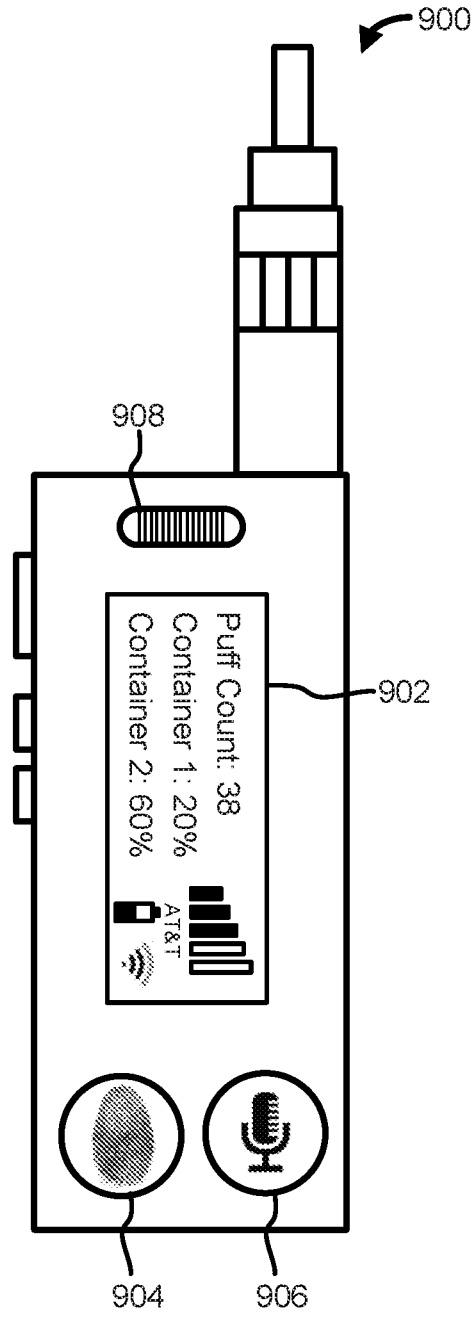
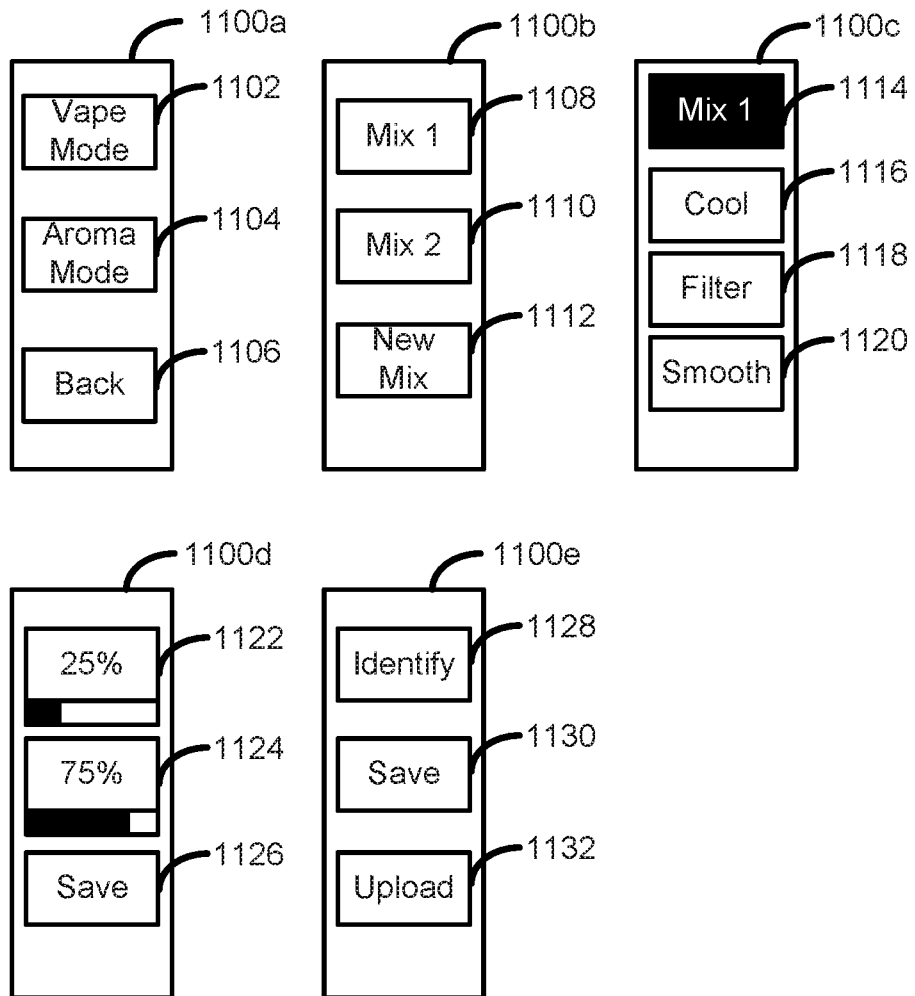

FIG. 11



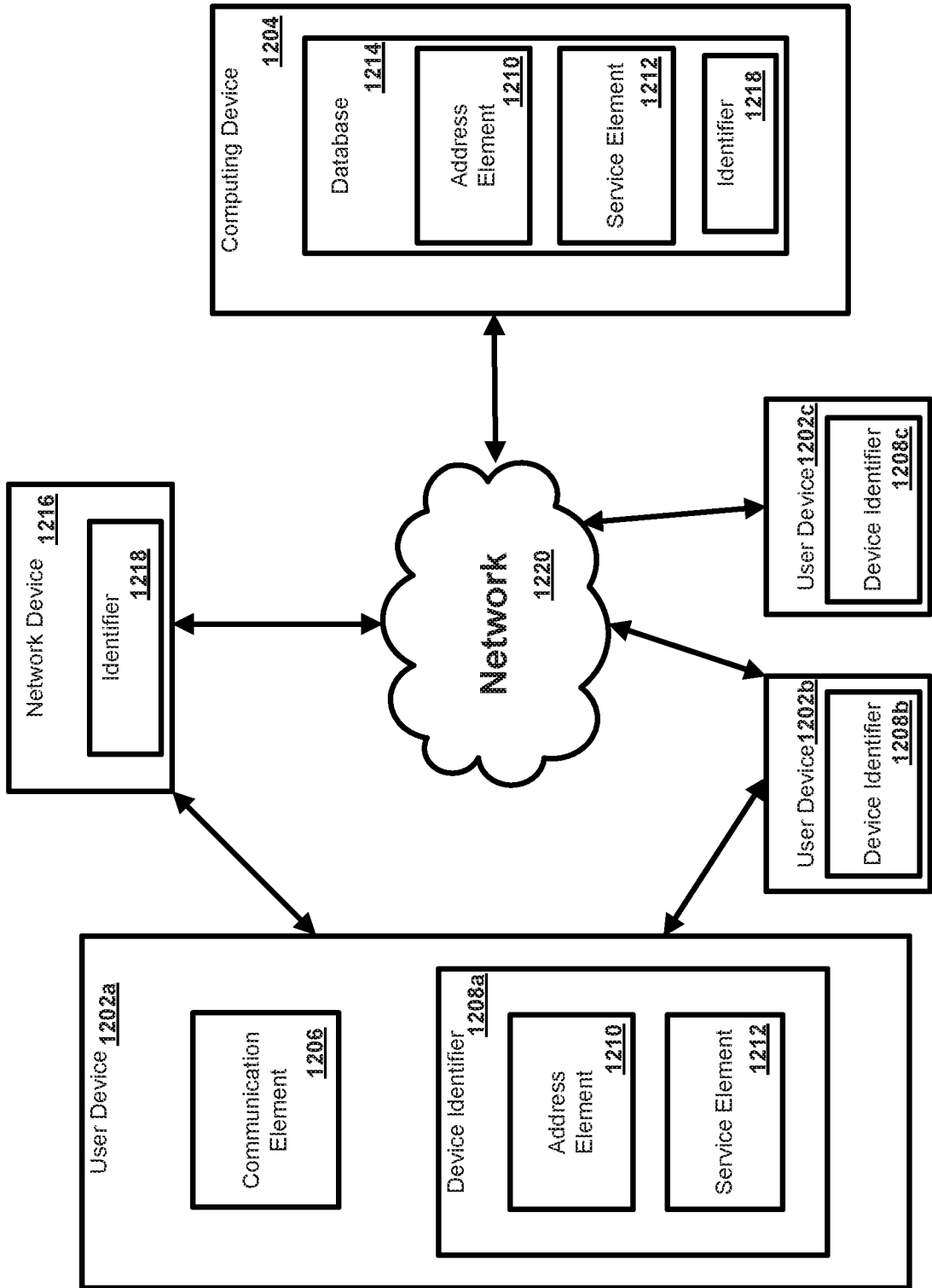

FIG. 12

FIG. 13

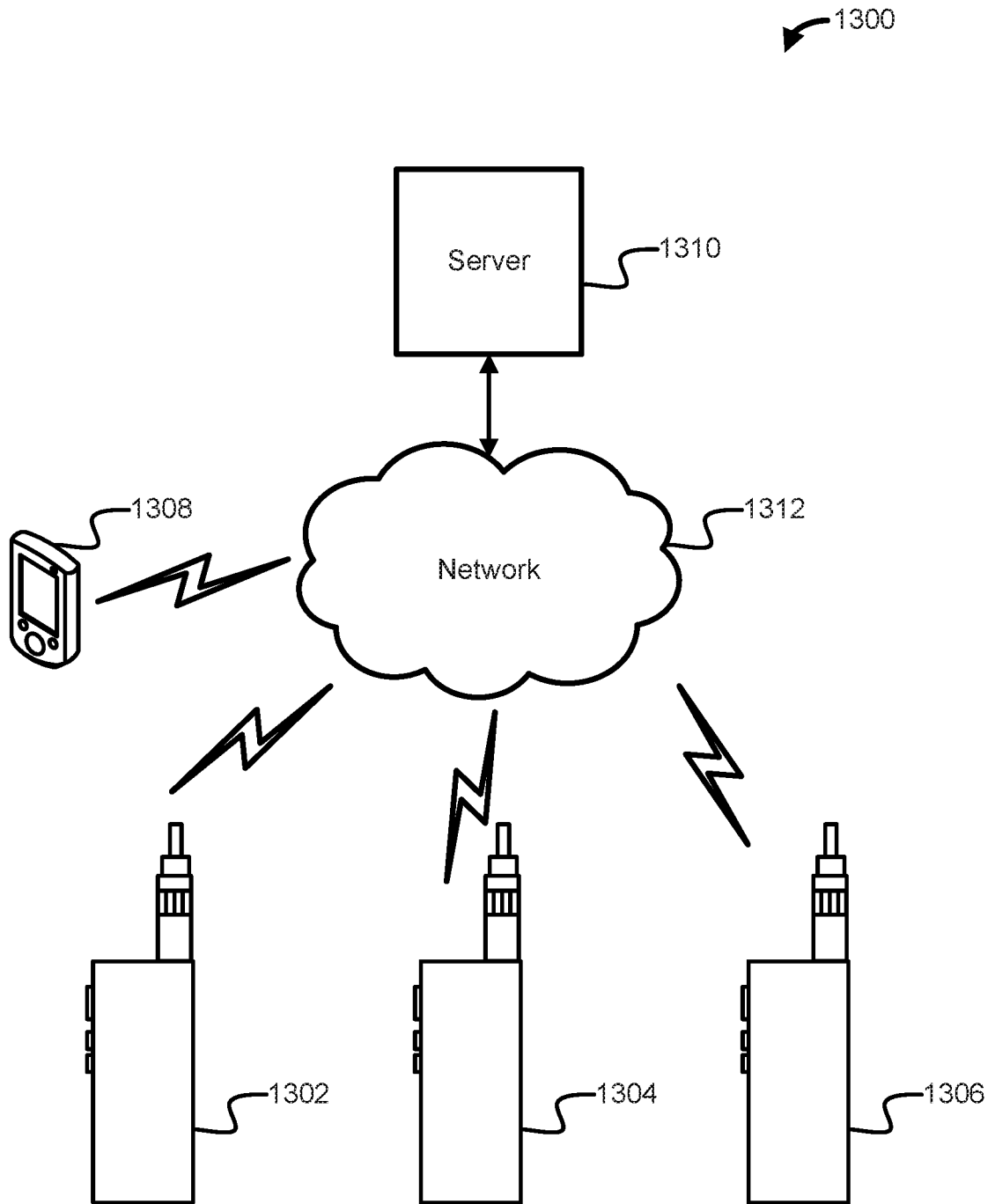

FIG. 14

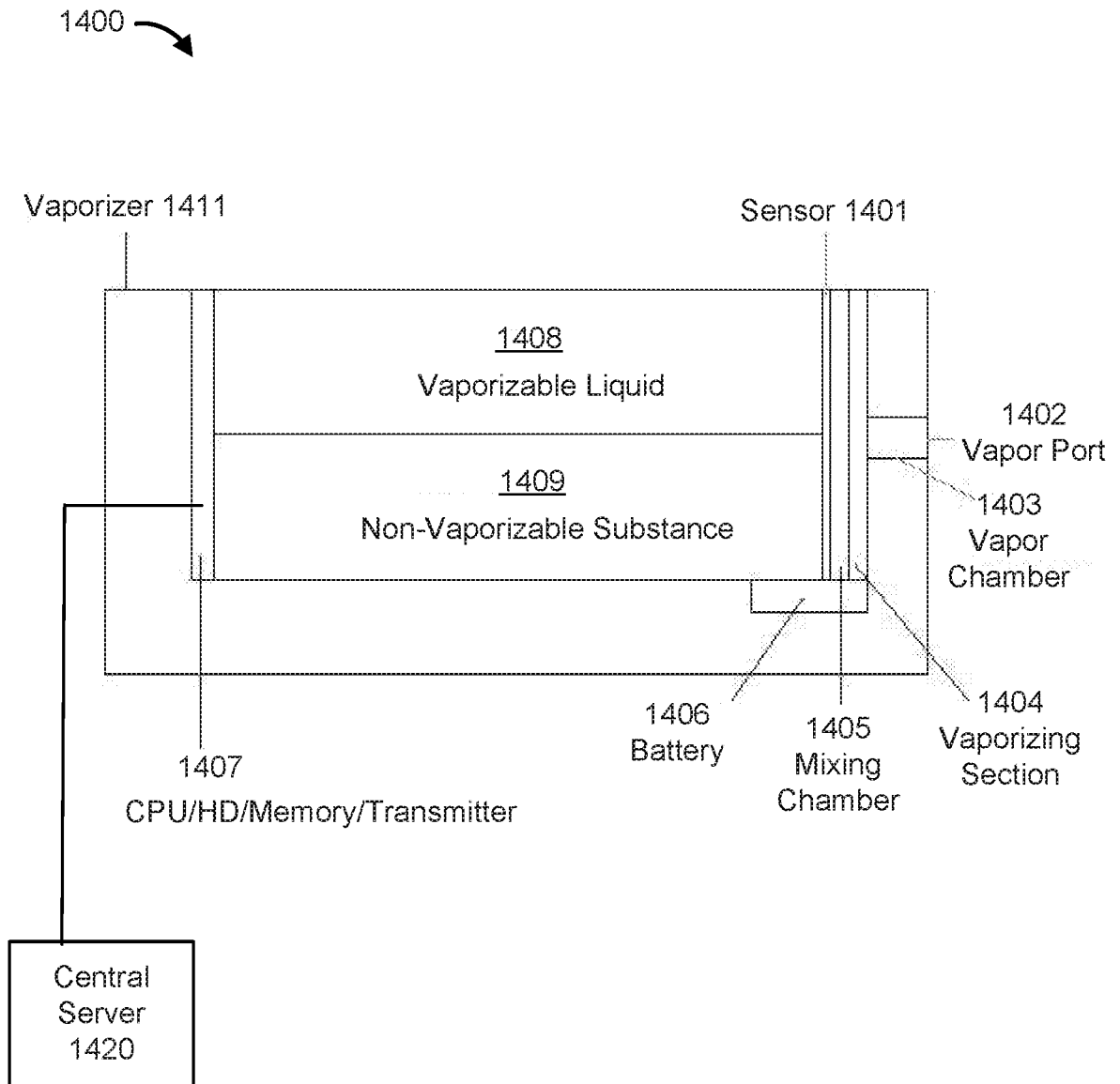

FIG. 16

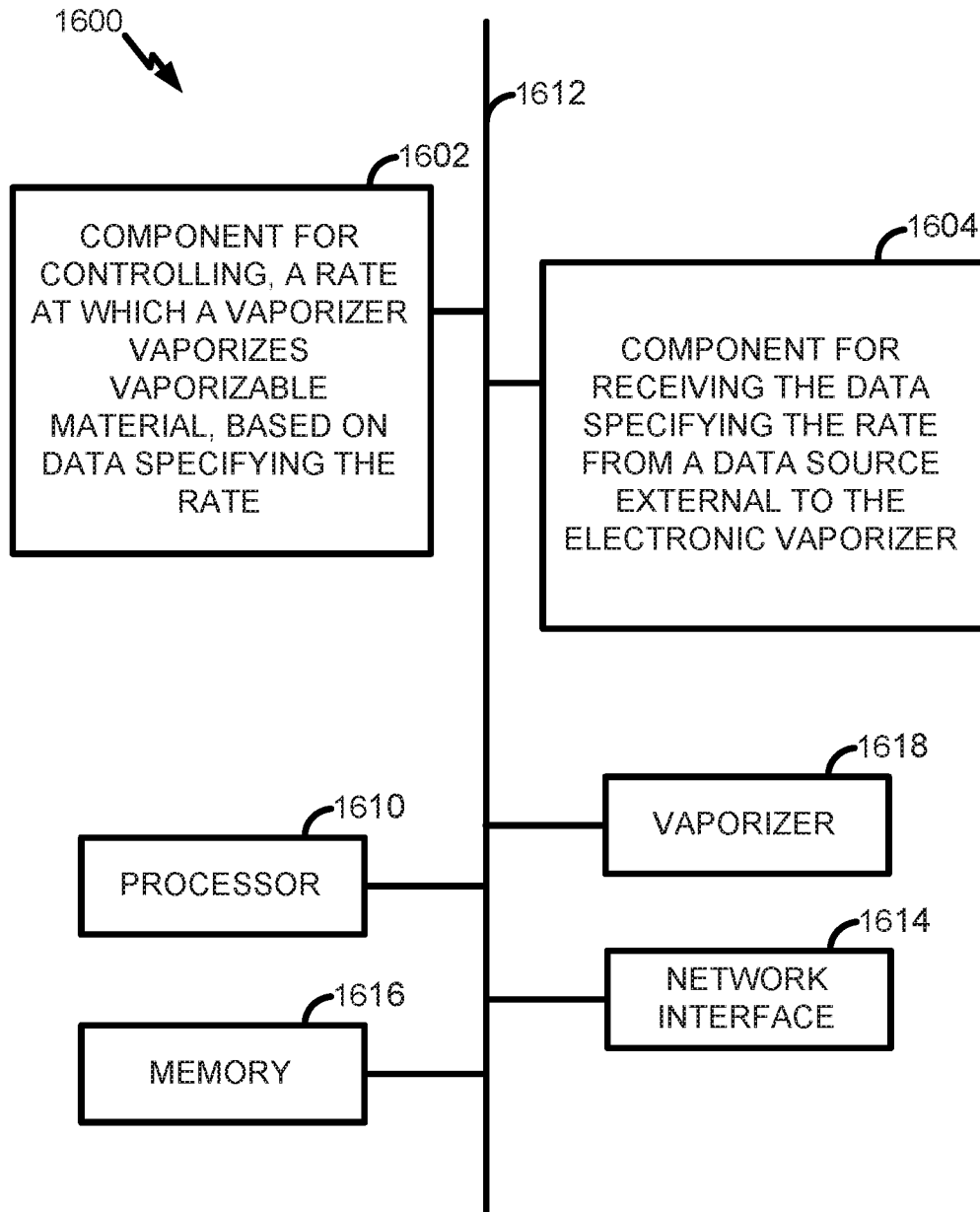

FIG. 17

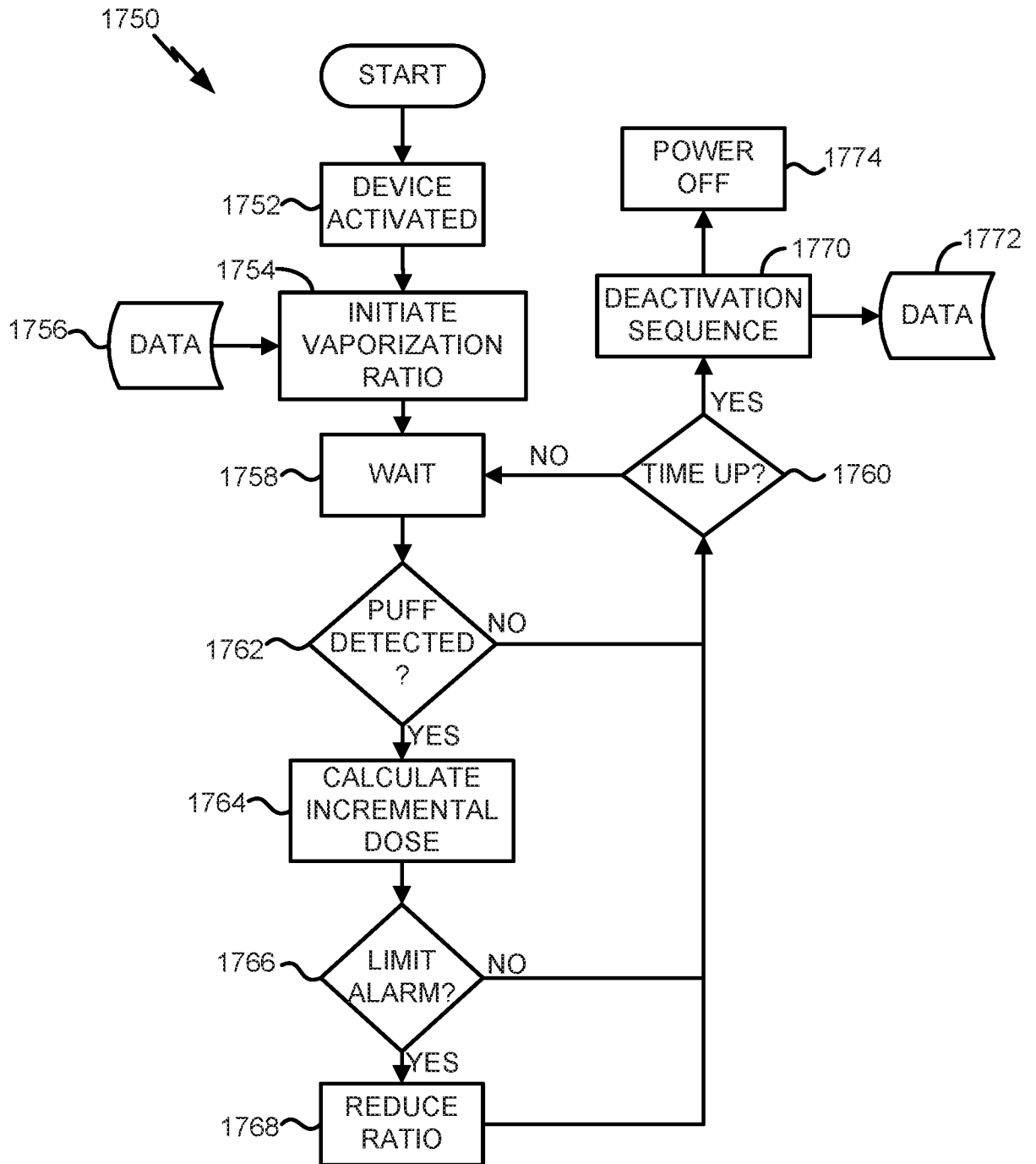
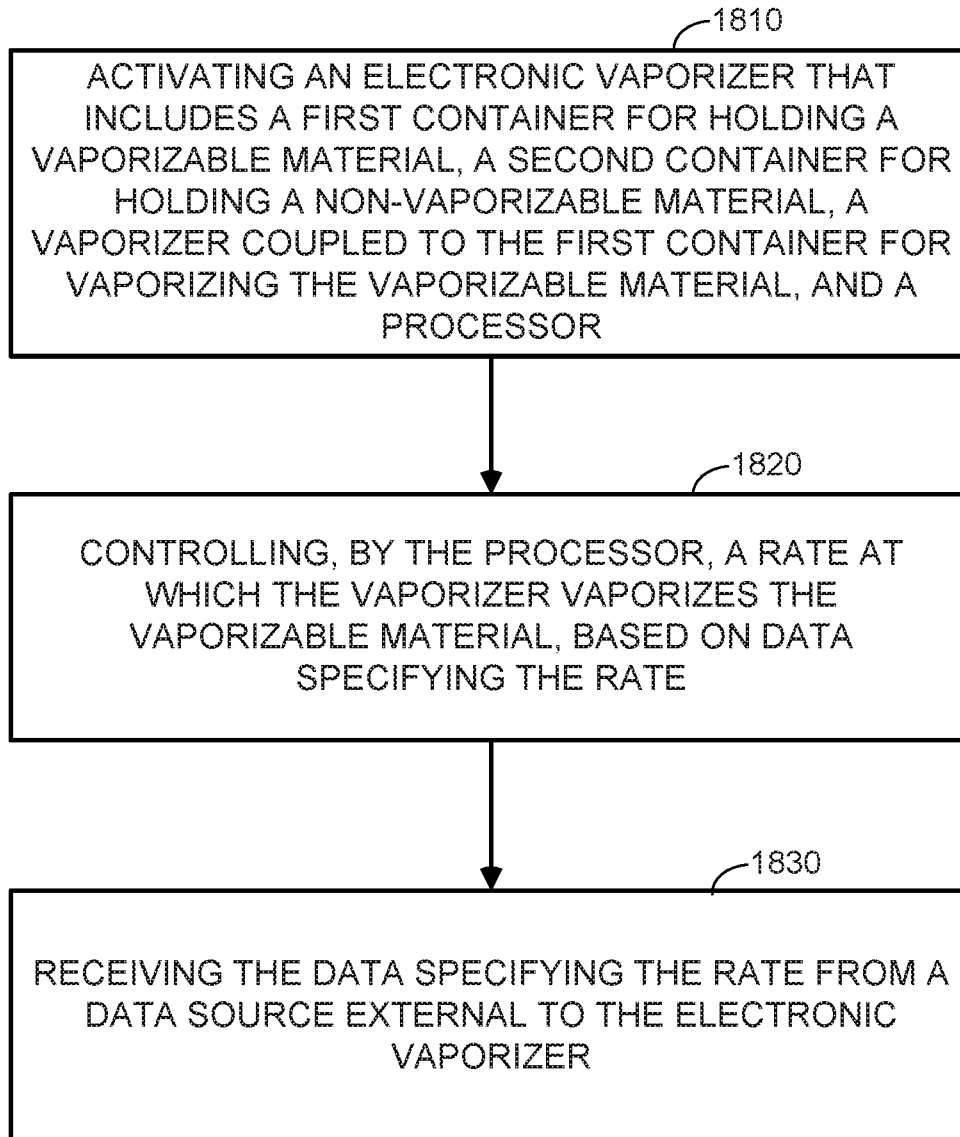

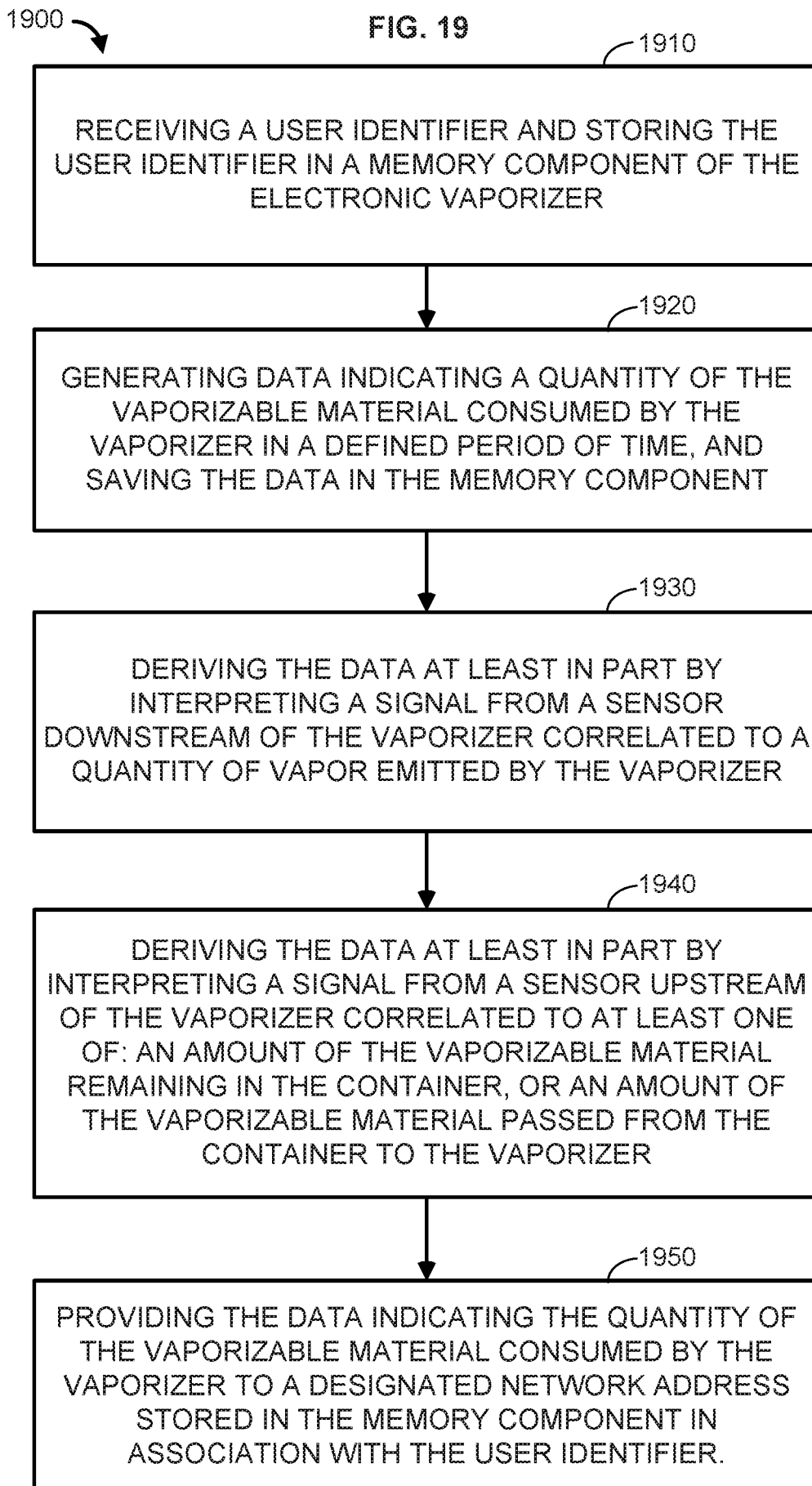
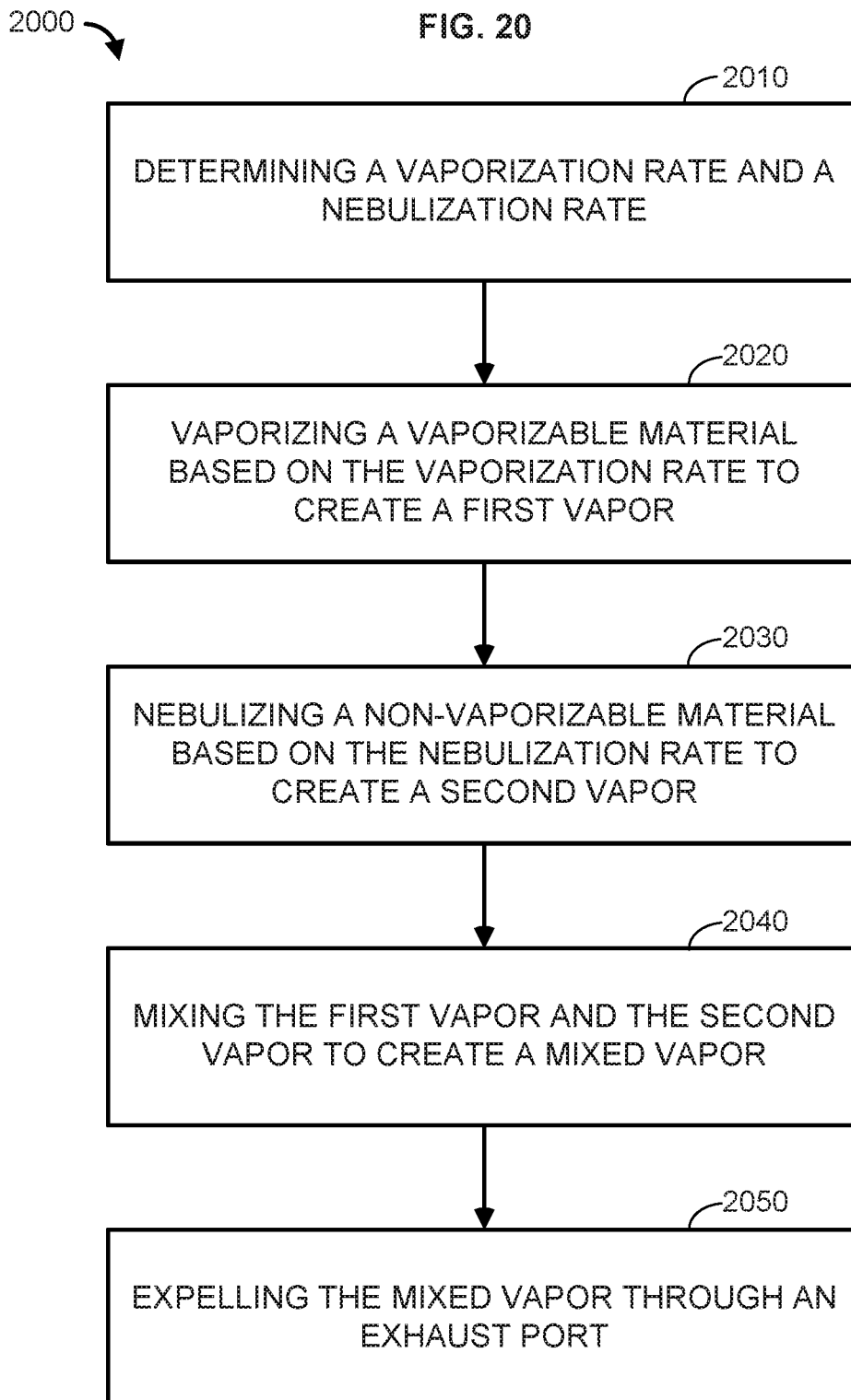

FIG. 18

1800 





INTERNATIONAL SEARCH REPORT

International application No.

PCT/US 16/32693

A. CLASSIFICATION OF SUBJECT MATTER

IPC(8) - A24B 15/18; A24D 1/00; A24F 47/00; A61M 16/14, 16/18; C23C 18/02; F02M 15/04 (2016.01)

CPC - A24F 47/002, 47/008; A61K 9/007; C23C 16/4486, 16/455, 16/46; G05B 15/02

According to International Patent Classification (IPC) or to both national classification and IPC

B. FIELDS SEARCHED

Minimum documentation searched (classification system followed by classification symbols)

IPC(8): A24B 15/18; A24F 47/00; A61M 16/14, 16/18; C23C 18/02; F02M 15/04 (2016.01)

CPC: A24F 47/002, 47/008; A61K 9/007; C23C 16/4486, 16/455, 16/46; G05B 15/02; USPC: 128/202.21; 261/142

Documentation searched other than minimum documentation to the extent that such documents are included in the fields searched

Electronic data base consulted during the international search (name of data base and, where practicable, search terms used)

PatSeer (US, EP, WO, JP, DE, GB, CN, FR, KR, ES, AU, IN, CA, Other Countries (INPADOC), RU, AT, CH, TH, BR, PH); EBSCO; PatentsGoogle; Google Scholar; sciencedirect.com; vaporizer, atomizer, rate, vaporizer component, nebulizer component, first container, second container, remote server, passcode, formula, vaporizable material, electronic vaporization device

C. DOCUMENTS CONSIDERED TO BE RELEVANT

Category*	Citation of document, with indication, where appropriate, of the relevant passages	Relevant to claim No.
X --- Y	WO 2014/201432 A 1 (PLOOM, INC.) 18 December 2014; figures 1-4; paragraphs [0002], [0013], [0035], [0058], [0061], [0067], [0076], [0078]-[0082], [00103]-[00104]	1-4, 13-15, 19-20 --- 5-12, 16-18, 21-23
Y	US 2013/0284192 A 1 (PELEG, E et al.) 31 October 2013; figure 7; paragraphs [0028], [0033], [0038]-[0039], [0045], [0055], [0058], [0060], [0063], [0081], [0085]	7-10, 21-22
Y	WO 2013/058980 A 2 (BROOKS INSTRUMENT, LLC) 25 April 2013; [0028], [0031]-[0033], [0037]	5-12, 16-17, 21-23
Y	(SCHRIPP, T et al.) Does e-cigarette consumption cause passive vaping. Indoor Air. 2013. vol. 23; table 1; page 27, paragraph 5	9, 10, 18
A	US 2005/0147749 A 1 (LIU, BYH et al.) 07 July 2005; entire document	1-23
A	US 2012/018301 A 1 (MONTASER, A) 17 May 2012; entire document	1-23
A	US 2011/0277757 A 1 (TERRY, NA et al.) 17 November 2011; entire document	1-23
A	US 2014/0001280 A 1 (FIELD, C et al.) 02 January 2014; entire document	1-23

 Further documents are listed in the continuation of Box C.
 See patent family annex.

* Special categories of cited documents:

"A" document defining the general state of the art which is not considered to be of particular relevance

"E" earlier application or patent but published on or after the international filing date

"L" document which may throw doubts on priority claim(s) or which is cited to establish the publication date of another citation or other special reason (as specified)

"O" document referring to an oral disclosure, use, exhibition or other means

"P" document published prior to the international filing date but later than the priority date claimed

"T" later document published after the international filing date or priority date and not in conflict with the application but cited to understand the principle or theory underlying the invention

"X" document of particular relevance; the claimed invention cannot be considered novel or cannot be considered to involve an inventive step when the document is taken alone

"Y" document of particular relevance; the claimed invention cannot be considered to involve an inventive step when the document is combined with one or more other such documents, such combination being obvious to a person skilled in the art

"&" document member of the same patent family

Date of the actual completion of the international search

13 July 2016 (13.07.2016)

Date of mailing of the international search report

19 AUG 2016

Name and mailing address of the ISA/

Mail Stop PCT, Attn: ISA/US, Commissioner for Patents
P.O. Box 1450, Alexandria, Virginia 22313-1450

Facsimile No. 571-273-8300

Authorized officer

Shane Thomas

PCT Helpdesk: 571-272-4300
PCT OSP: 571-272-7774