

J. L. Pijer. Truss Bridge.

N^o 2,538.
33,542.

Patented Oct. 22, 1861.

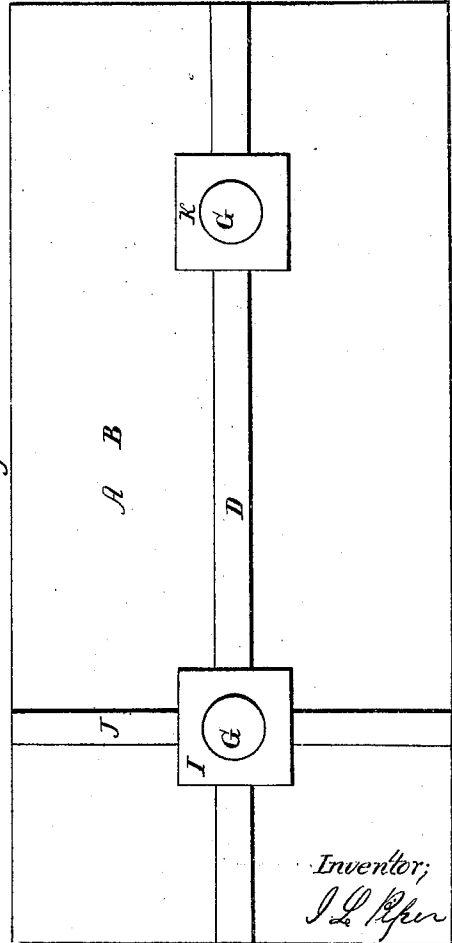
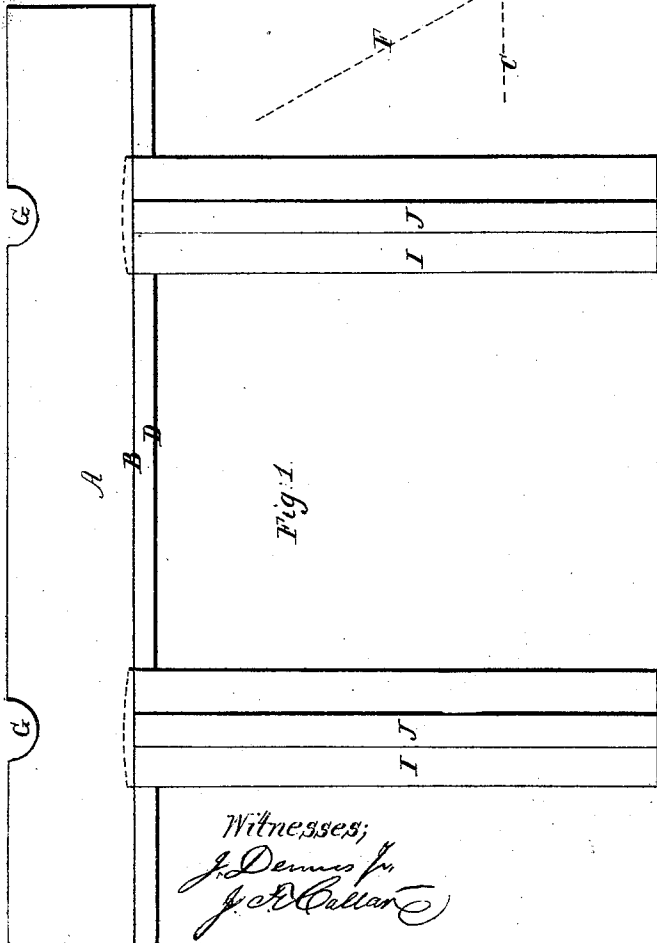
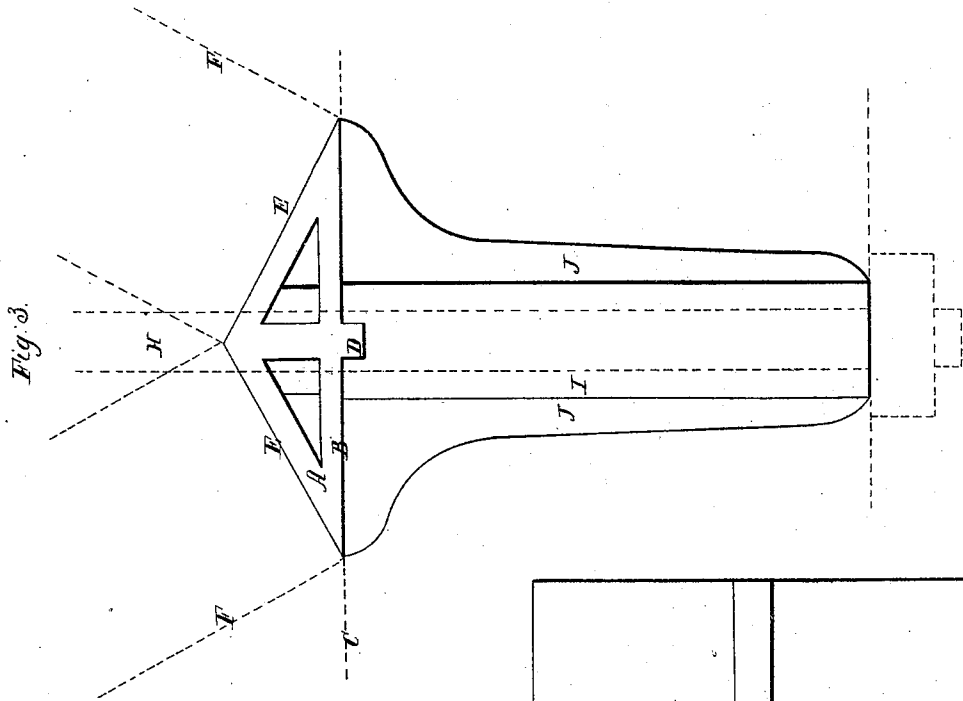

Witnesses;
J. Dennis for
J. L. Pijer

Inventor;
J. L. Pijer

UNITED STATES PATENT OFFICE.

JOHN L. PIPER, OF ALTOONA, PENNSYLVANIA.

IMPROVEMENT IN BEARING-BLOCKS FOR BRIDGE-TRUSSES.

Specification forming part of Letters Patent No. 33,542, dated October 22, 1861.

To all whom it may concern:

Be it known that I, JOHN L. PIPER, of Altoona, Blair county, and State of Pennsylvania, have invented a new, useful, and Improved Bearing-Block for the Braces of Bridges and Trusses; and I do hereby declare that the same is described and represented in the following specification and accompanying drawings.

The nature of my improved bearing-block for the braces of bridges and trusses consists in making the tubes for the bolts or tie-rods separate from the bed of the block, so that they will yield or vibrate when required without injuring or breaking either the bed or tube; also in rounding the ends of the tubes and fitting them to a curved seat in the bed, so that they will vibrate without materially lessening the bearing-surface between the bed and tube.

To enable others skilled in the art to make and use my improved bearing-block, I will proceed to describe it, referring to the accompanying drawings, in which the same letters indicate like parts in each of the figures.

Figure 1 is a side, and Fig. 2 an end, elevation of my improved bearing-block. Fig. 3 is a plan of the under side with one of the tubes removed.

In the drawings, A is the bed of the bearing-block, made of cast-iron in the form shown in the drawings or in such other form as will answer the purpose. The base B is designed to rest on the chords or string-pieces C. (Shown by dotted lines in Fig. 2.) There is a rib D in the center to fit a score cut across the chord C. The angles E E of the top of the bearing-block receive the ends of the braces F F. (Shown by dotted lines in Fig. 2.) This bearing-block is perforated at G G for the bolts or tie-rods of the truss, one of which rods is shown at H, Fig. 2, which rod passes down through the tube I and is provided with a screw-nut which acts against the end of the tube and is not affected by the shrinking of the wood of the chord C. These tubes I I are made in the form shown or in such other form as will answer the purpose, and provided with a hole for the bolts H. These tubes I I have flanges J J projecting from two sides and made in the form shown in the drawings, and

the upper end of the tube is rounded across the top, as shown by dotted lines in Fig. 1. This rounded end of the tube is fitted to a curved seat or mortise K, Fig. 3. These tubes and also the bed A may be cast hollow by using cores in the molds to make them so. When the chords or string-pieces of the bridge are fastened together, I cut some places to receive the tubes I I and drive them in, and then apply the bed on the top of them and put the bolts or rods through and apply the braces, and then screw up the nuts on the bolts. By making the tubes separate from the bed they can be fitted close and driven in tight with far less labor and made to fit much closer than if the tubes and bed were in one piece, for when the tubes and bed are in one piece it is very difficult to fit them to the chords so that they will bear uniformly, and still more difficult to screw up the bolts to the required pressure without breaking the tubes or bed. Hence it often happens that the structure has to be taken apart to remove a broken bearing-block and supply its place with a whole one; but by my improved bearing-block, with tubes made separate from the bed, all the difficulty and inconvenience are avoided and remedied, because the tubes yield or vibrate independent of the bed, and therefore neither of them is liable to be broken in screwing up the bolts or in applying them to the chords.

I believe I have described and represented my improved bearing-block for the braces of bridges and trusses so as to enable any person skilled in the art to make and use it.

I will now state what I desire to secure by Letters Patent, to wit:

1. Making the tubes for the bolts separate from the bed of the block, so that they can yield or vibrate when required without injuring or breaking either the bed or table.
2. Rounding the ends of the tubes and fitting them to a curved seat in the bed, so that they can vibrate without materially lessening the bearing-surface between the bed and tube, substantially as described.

JOHN L. PIPER.

Witnesses:

J. DENNIS, Jr.,
J. F. CALLAN.