

H. J. BAYARD.
CAR BRAKE.

APPLICATION FILED FEB. 23, 1904.

NO MODEL.

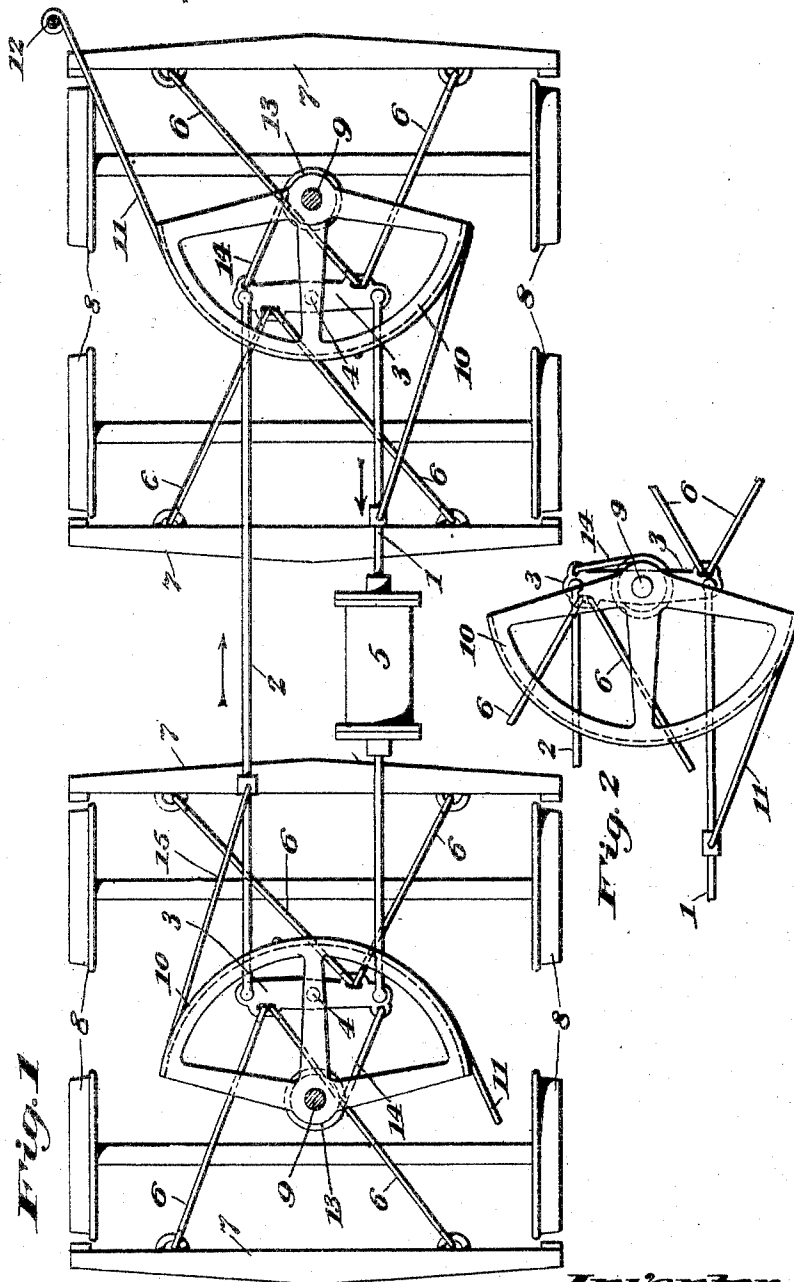

Witnesses

J. H. Bruce
C. S. Kelly

Inventor

Henry J. Bayard

By *J. B. Caplinger*
Attorney.

UNITED STATES PATENT OFFICE.

HYRAM J. BAYARD, OF CHICAGO, ILLINOIS.

CAR-BRAKE.

SPECIFICATION forming part of Letters Patent No. 776,717, dated December 6, 1904.

Application filed February 23, 1904. Serial No. 194,726. (No model.)

To all whom it may concern:

Be it known that I, HYRAM J. BAYARD, a citizen of the United States of America, and a resident of Chicago, Cook county, Illinois, have invented certain new and useful Improvements in Car-Brakes, of which the following is a specification.

This invention relates to certain improvements in car-brakes, and has for its object to provide a brake mechanism which shall be adapted for operation by hand or for connection with an air-brake system for securing a greatly-increased leverage and consequent increased efficiency without multiplication of levers, such as are commonly employed for effecting such results, the structure being of an extremely simple and inexpensive nature and being also of exceeding strength and durability by reason of the absence of such multiplication of levers.

The invention consists in certain novel features of the construction, combination, and arrangement of the several parts of the improved brake mechanism, whereby certain important advantages are attained and the device is rendered simpler, cheaper, and otherwise better adapted and more convenient for use, all as will be hereinafter fully set forth.

The novel features of the invention will be carefully defined in the claims.

In the accompanying drawings, which serve to illustrate my invention, Figure 1 is a plan view of the brake mechanisms as they appear beneath the car when the platform and body are removed therefrom, the various parts being illustrated somewhat diagrammatically. Fig. 2 is a partial view showing a modified form of the improved brake mechanism.

As seen in the views, 1 and 2 are two rods extended lengthwise beneath the platform of a car, one of such rods, as 1, being adapted for operation from an air-brake cylinder in a well-known way, so that it may, by means of such cylinder, be moved longitudinally to set and release the brakes. Adjacent to opposite ends of the car the said rods 1 and 2 have connection with opposite ends of two levers 3 3, centrally pivoted, as seen at 4, beneath the car-platform. The pivots 4 4 of levers 3 3, may, if desired, be extended up from the car-

truck frames, (not shown,) or, as seen in Fig. 2, in certain instances said levers 3 3 may be pivotally mounted on the king-bolts 9 9, whereon said truck-frames are commonly pivoted also.

From opposite ends of each lever 3 are extended oppositely-directed links or connections 6 6, arranged in two pairs, and each such pair of links or connections 6 6 has connection with one of the brake-beams 7 7, the ends of each brake-beam 7 carrying shoes designed to be pressed upon the treads of the wheels 8 8 when the levers 3 are swung pivotally and to be withdrawn from engagement with the wheels when the levers are swung pivotally in an opposite direction.

9 9 represent the king-bolts whereon the truck-frames (not shown) are pivotally mounted, and on these king-bolts 9, above such truck-frames, are held for turning movement segment-shaped parts 10 10, having grooved peripheries and connected with drums 13 of less radius than the segmental parts, on which drums 13 are secured and adapted to be wound in rotative movement of the drums in one direction and to be unwound therefrom in opposite rotative movements flexible connections or chains 14, which are each connected with an end of the adjacent lever 3 in such a way that when the connection 14 is wound on the drum it will exert a draft upon the lever 3 to swing the same pivotally in a direction adapted to set the brake-shoes on the trucks 8, and when the connection 14 is unwound from drum 13 the lever 3 will be permitted to swing in a reverse direction to release the brake-shoes from the trucks.

Each of the segmental parts 10 has at one side of its grooved perimeter an attached chain or connection 11, and at its opposite side a similar attached chain or connection 15, and these chains or connections are adapted when drawn upon to turn the segmental parts 10 upon the king-bolts 9 in such a way as to wind up the connections 14 on drums 13 and set the brakes, and when the brakes are released and drum 13 moves in a reverse direction to unwind connection 14 it will be obvious that since part 10 is connected and moves with the drum the chains or connections 11

55

60

65

70

75

80

85

90

95

100

and 15 will be wound on the grooved perimeter of such part 10.

The connections 11 11 of the respective segmental parts 10 have ends connected to and adapted to be wound on brake-staffs 12 in a well-known way, which staffs are adapted to be turned by hand-power to set the brakes, and the connections or chains 15 of the respective segmental parts 10 are connected with levers 3 and through said levers with the respective rods 1 and 2 in such a way that when said rods are moved in one direction by actuation of the piston in the brake-cylinder 5, as indicated by the arrows, so as to pivotally move levers 3 and to set the brakes, a draft will be exerted upon the chains or connections 15 15 in such a way as to turn the parts 10 and drums 13 and wind the slack of the connections 14 upon said drums, and when the rods 1 and 2 are moved in a reverse direction the connections between said rods and the ends of levers 3 3 will reversely swing said levers to release the brakes and at the same time through connections 14 will reversely turn the drums 13 and parts 10. In this way it will be understood that when the brakes are set by hand a materially-increased leverage is exerted through the interposed parts 10, owing to their radii being much greater than the drums 13, whereon connections 14 are adapted to be wound, and in this way a greatly-increased power is permitted to be applied to the brake-beams to set the brakes without the interposition of levers such as are commonly employed for effecting a similar result, and since the parts 10, 13, and 3 are capable of being made of great strength and rigidity it will be evident that a greatly-improved result is attained over what is commonly attained by the employment of a multiplication of levers in brake mechanisms as heretofore devised.

From the above description it will be seen that the improved brake mechanism is of an extremely simple and inexpensive nature and is of great strength and durability, so as to be especially well adapted for use upon railway-cars and the like, and it will also be obvious from the above description that the device is capable of considerable modification without material departure from the principles and spirit of the invention, and for this reason I do not wish to be understood as limiting myself to the precise form and arrangement of the several parts of the device herein set forth in carrying out my invention in practice.

Having thus described my invention, what I claim, and desire to secure by Letters Patent, is—

1. In a brake mechanism for cars, the combination of brake-beams with shoes to engage the treads of the wheels, a rotatively-mounted

drum, a flexible connection with one end winding on the drum, and the other end connected with the brake-beams, a part mounted to rotate in unison with the drum and of greater radius than the same and adapted when operated to turn the drum and wind said connection thereon to set the brakes, a brake-staff mounted to turn and a flexible connection one end of which is connected to and arranged to wind on said brake-staff and the other end of which is connected with said rotatively-mounted part.

2. In a brake mechanism for cars, the combination of brake-beams with shoes to engage the treads of wheels, a drum mounted to turn, a flexible connection with one end winding on the drum and its other end coupled to the brake-beams, a segmental part connected to turn in unison with said drum and of greater radius than the same, and air-operated and hand-operated mechanism for moving the segmental part.

3. In a brake mechanism for cars, the combination of brake-beams with shoes to engage the treads of wheels, a drum mounted to turn, a lever also held to turn, links connecting opposite ends of the lever with the brake-beams, a connection one end of which is held to the lever and the other end of which is connected to wind on the drum, a rotatively-mounted part of greater radius than the drum and connected to turn in unison therewith for moving the same to wind up said connection and set the brakes, a brake-staff mounted to turn and a flexible connection one end of which is connected to and arranged to wind on said brake-staff and the other end of which is connected with said rotatively-mounted part.

4. In a brake mechanism for cars, the combination of brake-beams with shoes to engage the treads of wheels, a drum mounted to rotate, a flexible connection with one end winding on the drum and its other end coupled to the brake-beams, a part of greater radius than and mounted to rotate in unison with the drum, a brake-staff mounted to turn, a connection one end of which is connected with and arranged to wind on the brake-staff and the other end of which is connected with said rotatively-mounted part to turn the same to set the brakes when the brake-staff is turned in one direction, air-operated brake mechanism connected with the brake-beams and arranged to set the brakes and a connection extended from the air-operated mechanism to said rotatively-mounted part to return the same to position after the brakes are released.

Signed at Chicago this 16th day of December, 1903.

HYRAM J. BAYARD.

Witnesses:

J. D. CAPLINGER,
C. S. KELLEY.