



US00D644998S

(12) **United States Design Patent**
Purdy et al.

(10) **Patent No.:** **US D644,998 S**
(45) **Date of Patent:** **** Sep. 13, 2011**

(54) **CLOSED COMPRESSION-TYPE COAXIAL CABLE CONNECTOR**

(75) Inventors: **Eric Purdy**, Constantia, NY (US); **Chris Natoli**, Fulton, NY (US); **Noah Montena**, Syracuse, NY (US)

(73) Assignee: **John Mezzalingua Associates, Inc.**, East Syracuse, NY (US)

(**) Term: **14 Years**

(21) Appl. No.: **29/379,407**

(22) Filed: **Nov. 19, 2010**

(51) **LOC (9) Cl.** **13-03**

(52) **U.S. Cl.** **D13/151**

(58) **Field of Classification Search** D13/133,
D13/151, 153, 154, 156, 184; 439/180, 253,
439/254, 255, 256, 257, 378, 380, 447, 527,
439/533, 543, 578, 583, 584, 585, 623, 944

See application file for complete search history.

(56) **References Cited**

U.S. PATENT DOCUMENTS

D511,499 S	*	11/2005	Chung	D13/154
D543,948 S	*	6/2007	Montena	D13/154
D556,693 S		12/2007	Montena		
D571,732 S		6/2008	Chawgo et al.		
D572,197 S		7/2008	Chawgo et al.		
D572,198 S		7/2008	Chawgo et al.		
D572,199 S		7/2008	Chawgo et al.		
D572,200 S		7/2008	Chawgo		
D572,663 S		7/2008	Chawgo et al.		
D574,780 S		8/2008	Chawgo et al.		
D574,781 S		8/2008	Chawgo et al.		
D574,782 S		8/2008	Chawgo et al.		
D574,783 S		8/2008	Chawgo et al.		
D574,784 S		8/2008	Chawgo		
D577,681 S		9/2008	Amidon		
D577,682 S		9/2008	Amidon		
D577,683 S		9/2008	Chawgo et al.		
D578,073 S		10/2008	Amidon		
D578,077 S		10/2008	Amidon		

D578,482 S	10/2008	Amidon	
D578,488 S	10/2008	Amidon	
D580,874 S	11/2008	Amidon	
D580,875 S	11/2008	Amidon	
D596,579 S	7/2009	Chawgo et al.	
D596,580 S	7/2009	Chawgo et al.	
D596,581 S	7/2009	Amidon	
D603,802 S	11/2009	Amidon	
D603,803 S	11/2009	Amidon	
D605,136 S	12/2009	Amidon	
D607,820 S	* 1/2010	Thorner D13/133
D611,912 S	3/2010	Montena	
D617,286 S	6/2010	Montena	
D620,893 S	* 8/2010	Stock D13/151
2008/0113554 A1*	5/2008	Montena 439/585
2008/0194142 A1*	8/2008	Wlos 439/584
2010/0029131 A1*	2/2010	Eriksien 439/578
2010/0112855 A1*	5/2010	Paynter et al. 439/584

* cited by examiner

Primary Examiner — Daniel Bui

(74) *Attorney, Agent, or Firm* — Stephen R. Yoder, Esq.

(57) **CLAIM**

The ornamental design for a closed compression-type coaxial cable connector, as shown and described.

DESCRIPTION

FIG. 1 is a front perspective view of the present invention showing our design for a closed compression-type coaxial cable connector;

FIG. 2 is a back perspective view thereof;

FIG. 3 is a top view thereof, the claimed portion of which is a mirror image to a bottom view;

FIG. 4 is a right side view thereof, the claimed portion of which is a mirror image to a left side view;

FIG. 5 is a front view thereof;

FIG. 6 is a back view thereof; and,

FIG. 7 is a front perspective view thereof, in use condition.

The broken line portion of the figure drawings is included for the purpose of illustrating environment and forms no part of the claimed design.

1 Claim, 7 Drawing Sheets

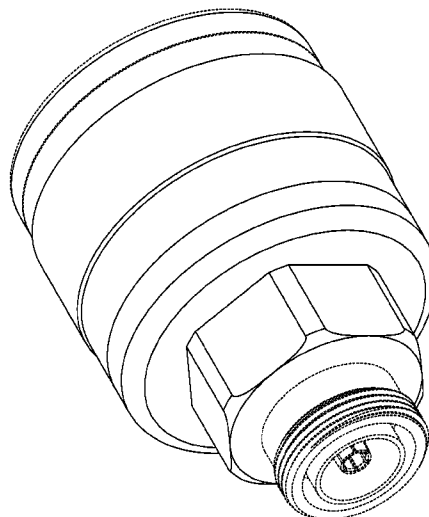

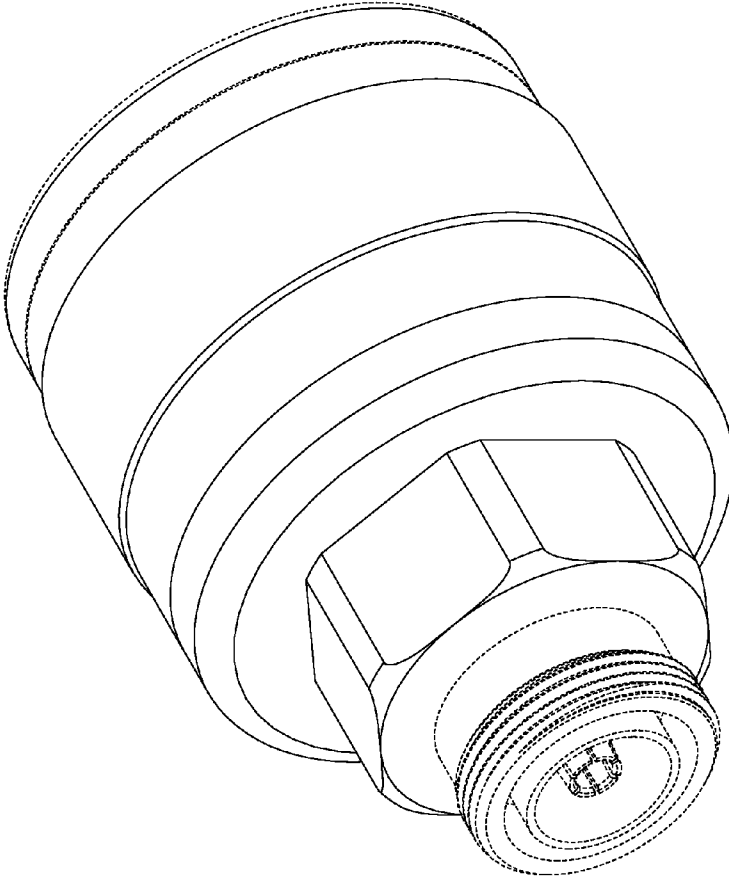

FIG. 1

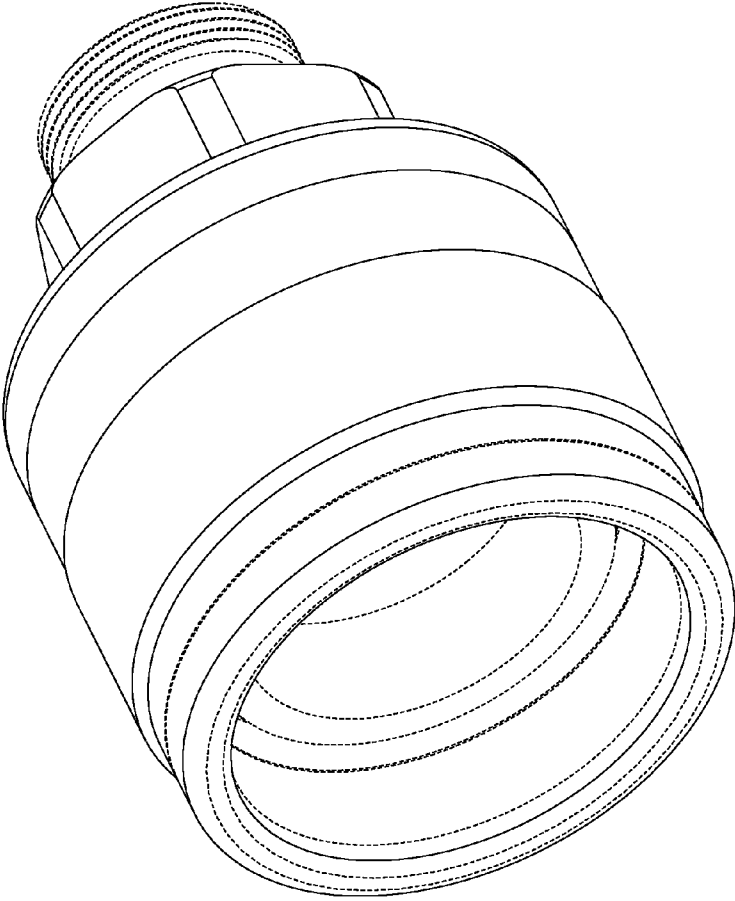

FIG. 2

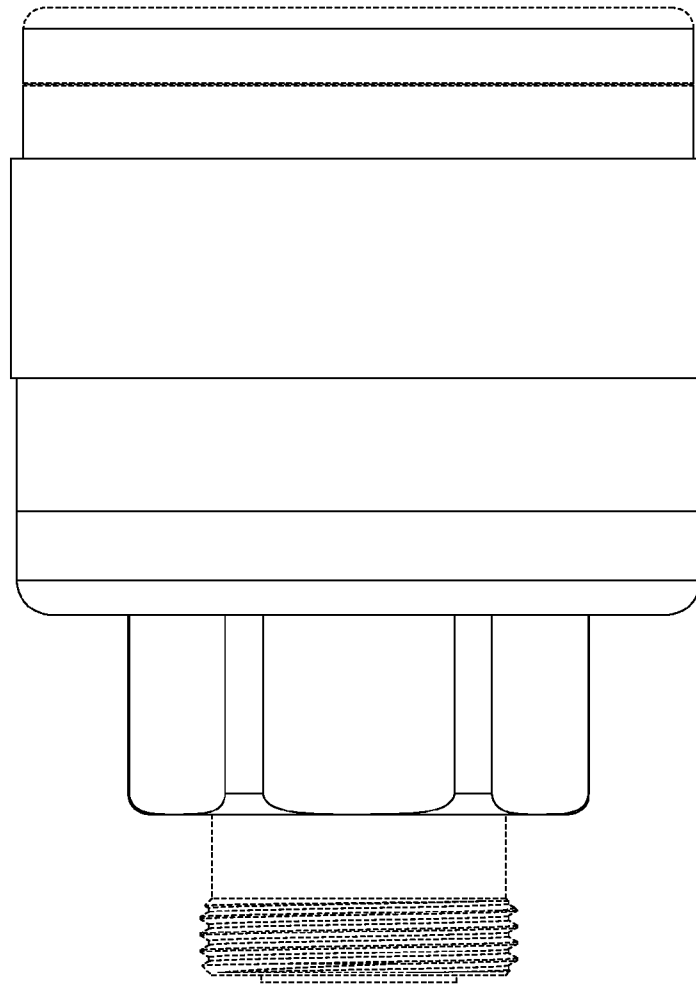

FIG. 3

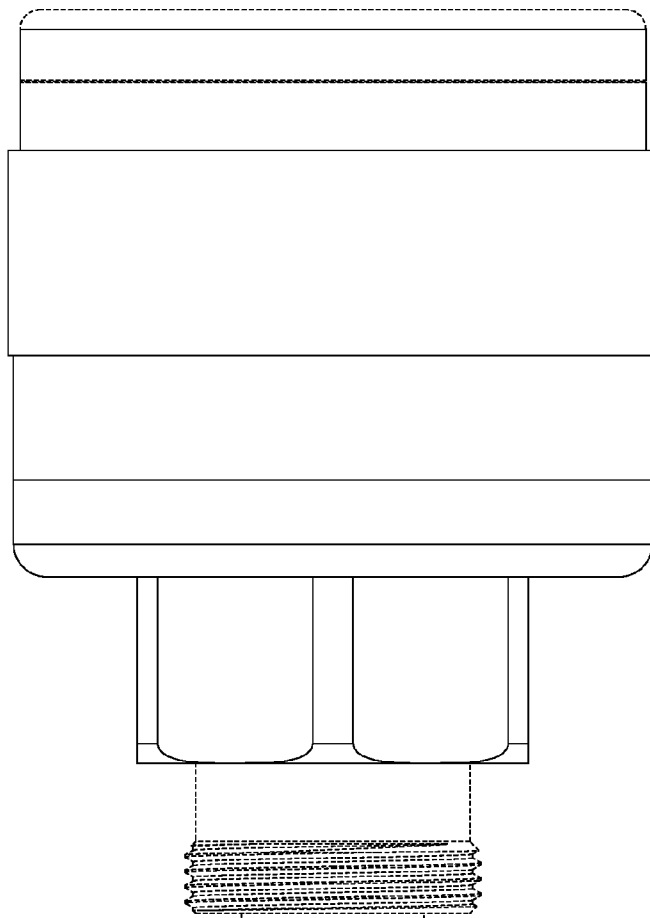

FIG. 4

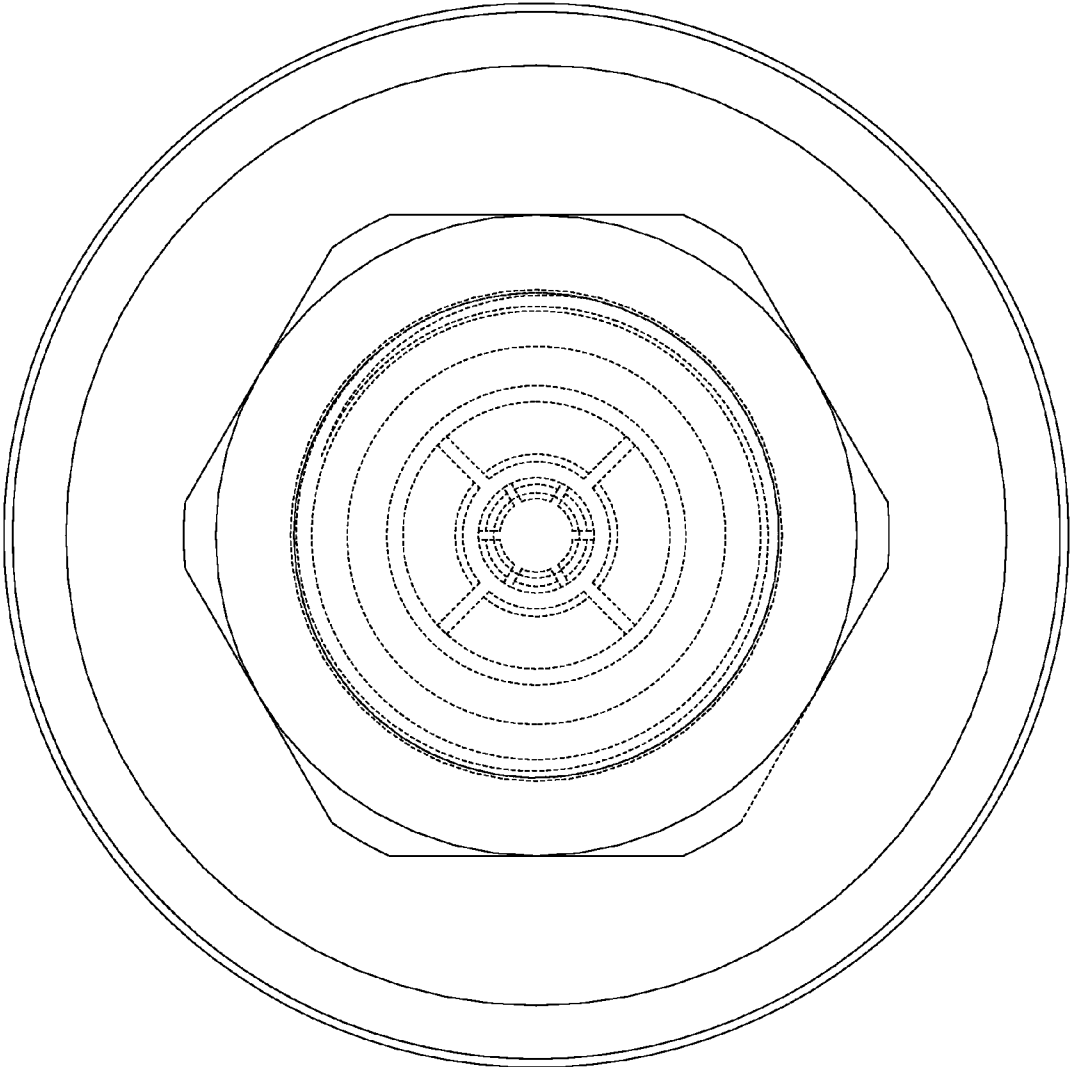

FIG. 5

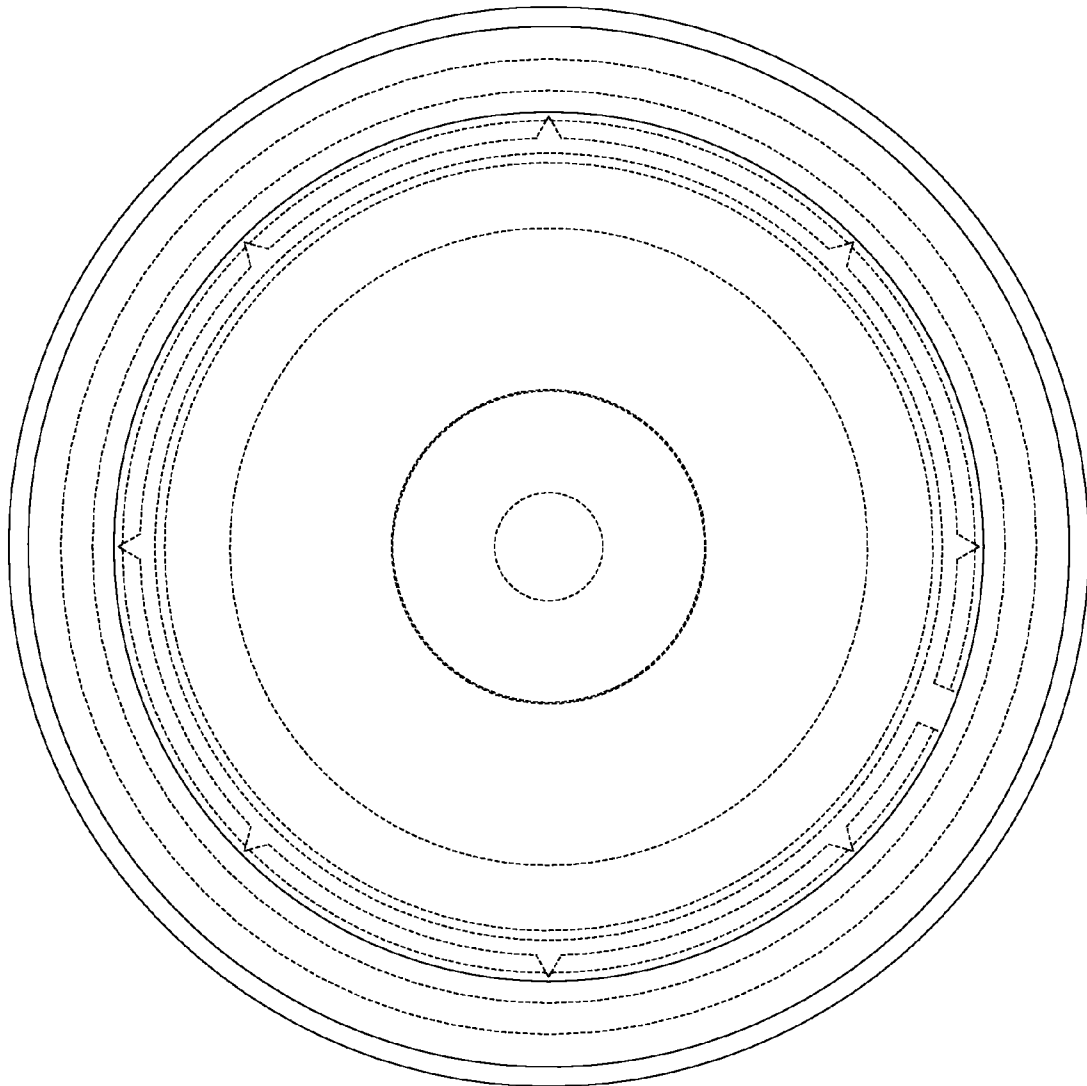

FIG. 6

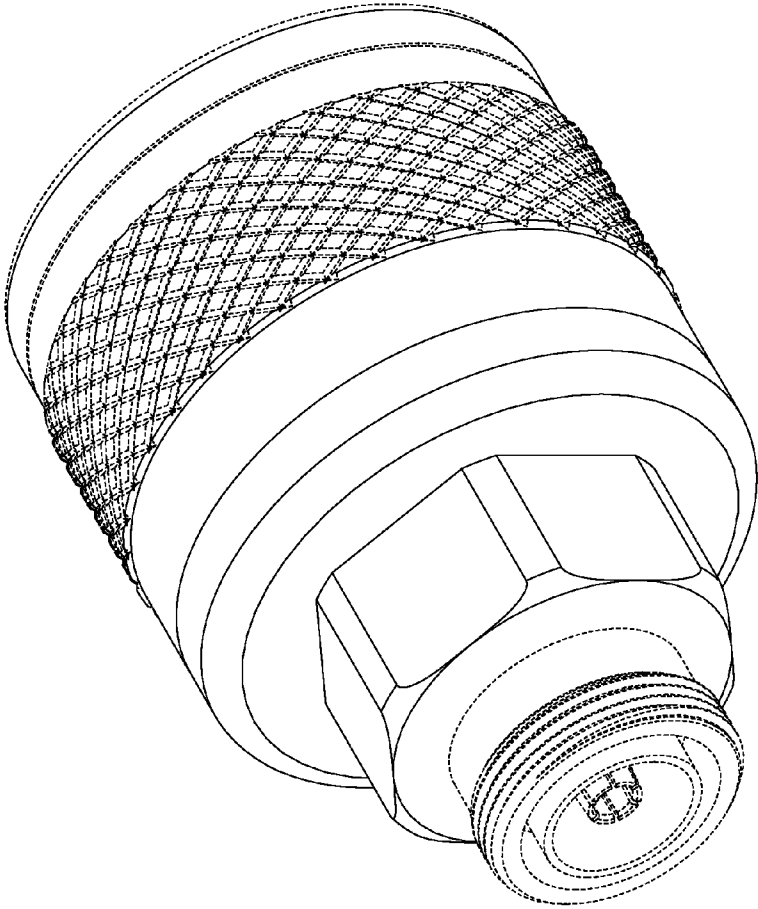

FIG. 7