

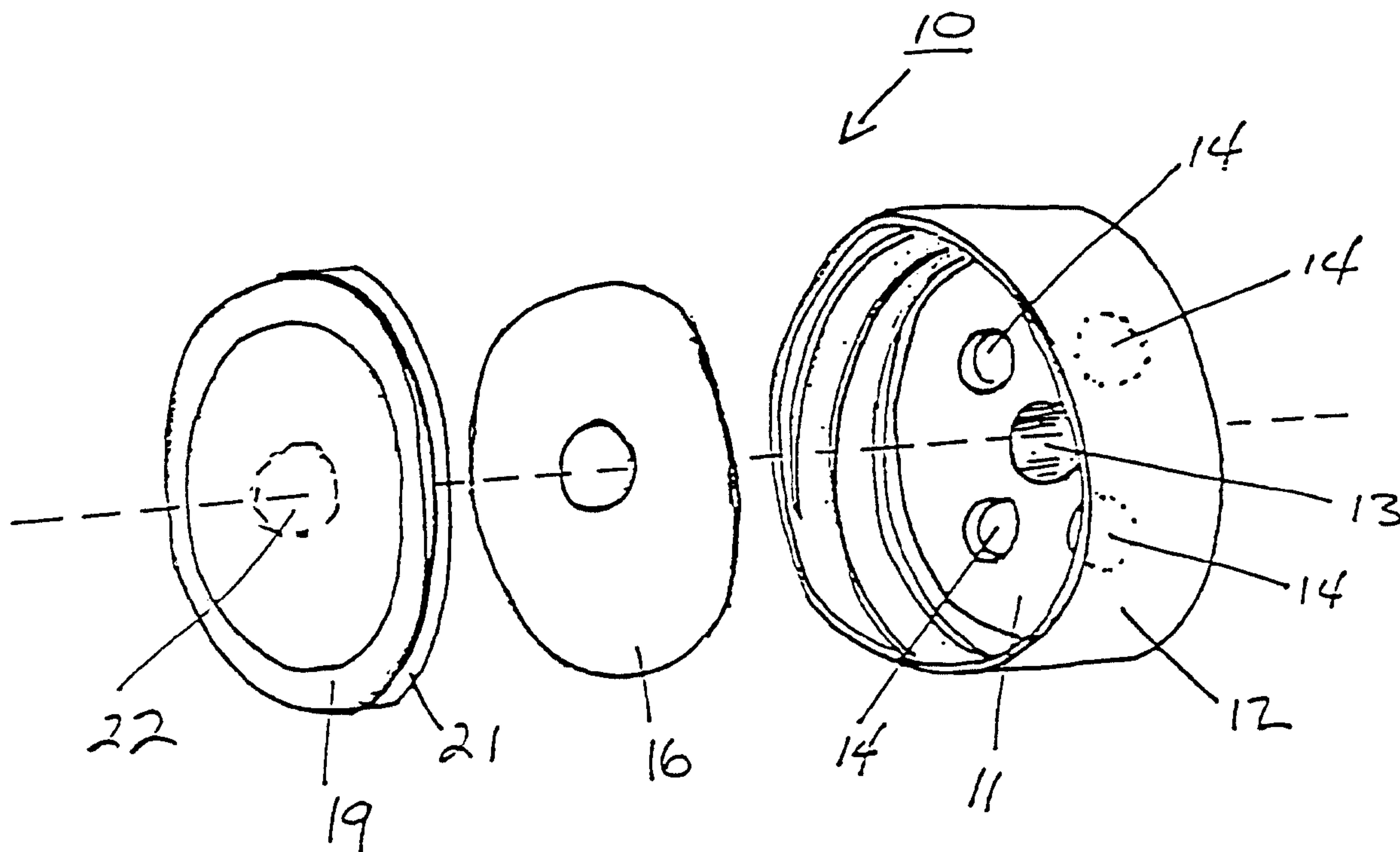

(22) Date de dépôt/Filing Date: 1991/11/05
 (41) Mise à la disp. pub./Open to Public Insp.: 1992/05/07
 (45) Date de délivrance/Issue Date: 2003/10/21
 (30) Priorité/Priority: 1990/11/06 (609,676) US

(51) Cl.Int.⁵/Int.Cl.⁵ A61M 39/00
 (72) Inventeurs/Inventors:
 RANI, ROBERT G., US;
 HAHN, DOUGLAS E., US
 (73) Propriétaire/Owner:
 NOVARTIS NUTRITION INC., CH
 (74) Agent: KIRBY EADES GALE BAKER

(54) Titre : DISPOSITIFS D'OBTURATION DE CONTENANTS DE FLUIDES ENTERIQUES
 (54) Title: CLOSURE DEVICES FOR ENTERAL FLUID CONTAINERS



(57) Abrégé/Abstract:

A closure device for connection to a fluid container which has an opening for receiving the device and a base section which may sealably cover the container opening; the base section having a spike receiving opening passing there through as well as at least one air vent which is spaced from the spike receiving opening and a hydrophobic air filter, associated with the air vent; adjoining the base section is an internal cover, which lies over the aperture, covering it and the base section, said internal cover having a pierceable portion which is in alignment with the spike receiving opening of the base section.

CLOSURE DEVICES FOR ENTERAL FLUID CONTAINERS

2054949

Abstract of the Disclosure

A closure device for connection to a fluid container which has an opening for receiving the device and a base section which may sealably cover the container opening; the base section having a spike receiving opening passing there through as well as at least one air vent which is spaced from the spike receiving opening and a hydrophobic air filter, associated with the air vent; adjoining the base section is an internal cover, which lies over the aperture, covering it and the base section, said internal cover having a pierceable portion which is in alignment with the spike receiving opening of the base section.

CLOSURE DEVICES FOR ENTERAL FLUID CONTAINERS

Background of the Invention

The present invention relates to fluid delivery systems. In one particular aspect, it relates to enteral fluid delivery systems utilizing closure devices for connection between an enteral fluid container and a patient feed line.

Summary of the Invention

Broadly, the present invention provides a closure device for connection to a fluid container which has an opening for receiving the device. The closure device has a base section which may sealably cover the container opening. The base section has a spike receiving opening passing there through with at least one aperture, e.g. an air vent on the base section which is spaced from the spike receiving opening. An air filter e.g., hydrophobic air filter, is associated with the air vent. Adjoining the base section is an internal cover, which lies over the aperture, covering it and the base section. The internal cover has a pierceable portion e.g., a weakened section, which is in alignment with the spike receiving opening of the base section. The pierceable portion is adapted to provide a hinge and a flap when pierced by a spike.

In a preferred embodiment of the invention, the closure device has a threaded wall portion projecting from the base section which wall portion is adapted to threadly receive a threaded connection of the fluid container. The fluid container may also have a pierceable seal covering the opening.

BRIEF DESCRIPTION OF THE DRAWINGS

2054949

Fig. 1 is an isometric view of a closure device of this invention.

Fig. 2 is a perspective view of the closure device of Fig. 1, showing the device in connection with a fluid container.

Fig. 3a, b, c and d are perspective views showing additional positions of the hydrophobic air filter.

Fig. 4 is a perspective view showing a gasket assembly of the closure device of this invention.

Fig. 5 is a perspective view showing the internal operation of a spike.

Fig. 6 is a perspective view showing the spike of Fig. 4 fully inserted in the device.

Fig. 7 is a Top View along the line 7-7 of Fig. 6 showing the rupture of seal 27.

Fig. 8 is a perspective view showing a snap-fit assembly of the closure device on a container.

Fig. 9 is a perspective view showing the closure device sealed across a container opening.

DETAILED DESCRIPTION OF THE PREFERRED EMBODIMENTS

Referring to Figs. 1 and 2, the closure device 10 generally comprises a base section 11 and a threaded wall portion 12. The base section 11 has a spike receiving

2054949

opening 13, and an air inlet aperture 14. There may be one or more air inlet apertures 14.

A hydrophobic air filter is associated with the air inlet apertures 14. The position and configuration of the filter may be varied depending upon the number of apertures 14. When multiple apertures are used, the filter may consist of a disk-like filter 16 as shown in Fig. 1. This filter 16 is preferably positioned on the inside of the closure device 10 (as shown in Fig. 1). It may also be positioned over the apertures on the outside of the closure device 10 (not shown).

One or more apertures 14 may also be covered by individual filters which may cover the apertures on the outside of the closure device 10, the inside of the closure device, or may lie within the apertures. These filter positions 16a, 16b, 16c and 16d are shown in Fig. 3a, b, c and d. Filter position 16d differs from position 16b, in that it is raised from the base section 11. The preferred filter position is on the inside of the closure device (16b). The individual filter may be secured to the closure device by any suitable means e.g., sonic welding, so that it will remain in position in relation to the aperture. Suitable hydrophobic air filters may be obtained from Pallflex Products Corp. (Pallflex EMFAB E01008E).

A spike receiving cylindrical member 17, aligned with the spike receiving opening 13, extends outwardly from the base section 11. The opening 13 and the cylindrical member 17 are adapted to receive a piercing spike 18.

An internal cover 19 lies over the filter 16 and the base section 11. The cover 19 may have a plurality of

rib members 20, to support and maintain the integrity of the cover. The cover may have a raised edge section 21 which may be adhered to the base section 11; and may have a center portion 22 which is in alignment with the spike receiving opening 13, and the cylindrical member 17, of the base section 11. Preferably, the internal cover 19 is concave in shape on its external surface, e.g., the surface facing away from the base section (see Fig. 2).

As shown in Fig. 2, the wall portion 12 of the closure device is threaded 23, to threadably receive the threaded neck 24 of a fluid container 26, e.g., an enteral fluid container. The container 26 has a seal 27, e.g., a foil seal, across the container opening. When the closure device 10 is attached to the container 26 (as shown in Fig. 2), the foil seal 27 contacts the cover 19.

In a preferred embodiment, the foil seal 27 may be adhesively sealed 25 to the cover 19. Preferably, the foil 27 is adhesively hot sealed (aseptically sealed) to the cover 19, by flowing a heated foodgrade hot melt adhesive between the foil seal 27 and the cover 19. The concave shape of the internal cover 19 insures that a thin layer of adhesive is placed between the cover and the foil seal. The cover 19 protects the apertures 14, and filters 16 from the adhesive, and also insures an open passage through the spike receiving opening 13. Suitable food contact adhesives which may be used are ethylene vinyl acetate based adhesive, (H.B.Fuller HL 7434); and polyethylene based adhesive, (H.B. Fuller HM 1002).

In an additional embodiment of the invention, a gasket 36 may be used in place of the hot melt adhesive (see Fig. 4). The gasket 36 may be formed in situ, or may be pre-formed, and is aseptically installed in the closure device 10.

The center portion 22 of the cover 19 is surrounded by a weakened area 28. It is preferred that the diameter of the weakened area 28 be larger than the piercing spike 18. The weakened area 28 breaks when the spike 18 is urged against it. As the spike 18 moves against the weakened area 28, the part closest to the tip 29 of the spike 18 breaks first (see Fig. 5). The weakened area 28 continues to break as the spike moves in the spike receiving opening 13.

As shown in Fig. 6, the weakened area 28 does not sever completely from the cover 19, but forms a hinge 31 on the side opposite the tip 29 of the spike 18. The hinge 31 and the center 22, thus form a flap 32 in the cover 19. As the flap 32 is raised by the spike 18, the seal 27 is ruptured, and the spike 18 enters the container 26. The flap 32 keeps the ruptured seal 27 away from the spike 18, insuring that air from the filter has access to the container 26. The spike 18 should penetrate sufficiently far into the container 26 so as not to draw air into the conventional central enteral fluid pathway of the spike. In a preferred embodiment of the flap 32, the innersurface of the center portion 22 e.g., the side facing the base section 11, is convex in shape 33. Thus, only the convex portion of the flap 32 rests on the spike 18, insuring that a sufficient air opening is maintained into the container, see Fig. 7. Though the cover 19 has been preferably described as having a center portion 22, with a circular weakened area 28, other spike penetrating weakened areas may be employed. For example, a weakened area in the form of a cross, triangle and the like, may be used. These alternate weakened areas sections are also pierceable by a spike, and provide air access to the container.

A cap 34 may be placed over the external end of the cylindrical member 17, to prevent contamination of the closure device 10 prior to use. The cap may be teathered to the

2054949

cylindrical member (not shown).

It is also within the scope of this invention, to use a snap-fit assembly of the closure device 10 and the container 26, thus, eliminating the threaded assembly. As shown in Fig. 8, a circumferential tab section 37 projecting from the base section 11, engages a rim 38 on the container 26, securing the closure device 10 to the container 26. After engagement, the closure device 10 may be further adhered to the container 26 by e.g., sonic welding.

The closure device 10 may also be sealed across a container opening without a threaded assembly, or snap-fit assembly by sealing e.g., sonic welding the base section 11 across the container opening, as shown in Fig. 9.

The closure device 10 of this invention when connected to an enteral fluid container, may be sterilized as a unit with the container. Alternately, the structure of the closure device 10 allows for it to be sterilized separate from an enteral fluid container. The internal cover 19 and cap 34, protects the internal portions of the device from contamination after sterilization.

To administer enteral fluid to a patient using the closure device of this invention, the cap 34 is removed, and a spike 18 (attached to an enteral delivery set) is plunged into the cylindrical member 17 and spike receiving opening 13 breaking the weakened area 28, and the container foil seal 27 as described above, thus releasing the enteral fluid to the patient, and allowing the fluid container to properly vent to the atmosphere.

CLAIMS:

1. A closure device for connection to a fluid container having an opening for receiving the device comprising;

a base section sealably covering the container opening, the base section having a spike receiving opening passing therethrough, and at least one aperture spaced from the spike receiving opening;

an air filter component associated with the at least one aperture;

an internal cover adjoining the base section, and covering the at least one aperture; the cover having a pierceable portion which is a weakened area in alignment with the spike receiving opening of the base section, said pierceable portion is adapted to provide a hinge and a flap when pierced by a spike.

2. The closure device of Claim 1, comprising a wall portion projecting from the base section, the wall portion being threaded and adapted to threadly receive a threaded connection of a fluid container.

3. The closure device of Claim 1, comprising a wall portion having a circumferential tab section projecting from the base section, the tab section being adapted to make a snap-fit with an external rim of a container.

4. The closure device of Claim 1, 2 or 3, having a plurality of apertures in the base section.

5. The closure device of any one of Claims 1 to 4, wherein the air filter is composed of hydrophobic material.

6. The closure device of any one of Claims 1 to 5, wherein the pierceable portion comprises a center portion surrounded by a weakened area, the weakened area adaptable to be pierced by a spike.

7. The closure device of Claim 6, wherein the inner-surface of the center portion is convex in shape.

- 8 -

8. The closure device of any one of Claims 1 to 7, having a cylindrical member aligned with the spike receiving opening of the base section.
9. The closure device of Claim 8, wherein the external end of the cylindrical member is covered by a cap.
10. The closure device of any one of Claims 1 to 9 connected to a container having a container seal across the container opening.
11. The closure device of Claim 10, wherein the container seal and the internal cover are adhesively sealed together with a food grade adhesive.
12. The closure device of Claim 10 or 11, wherein a gasket is in position between the container seal and the inner cover.

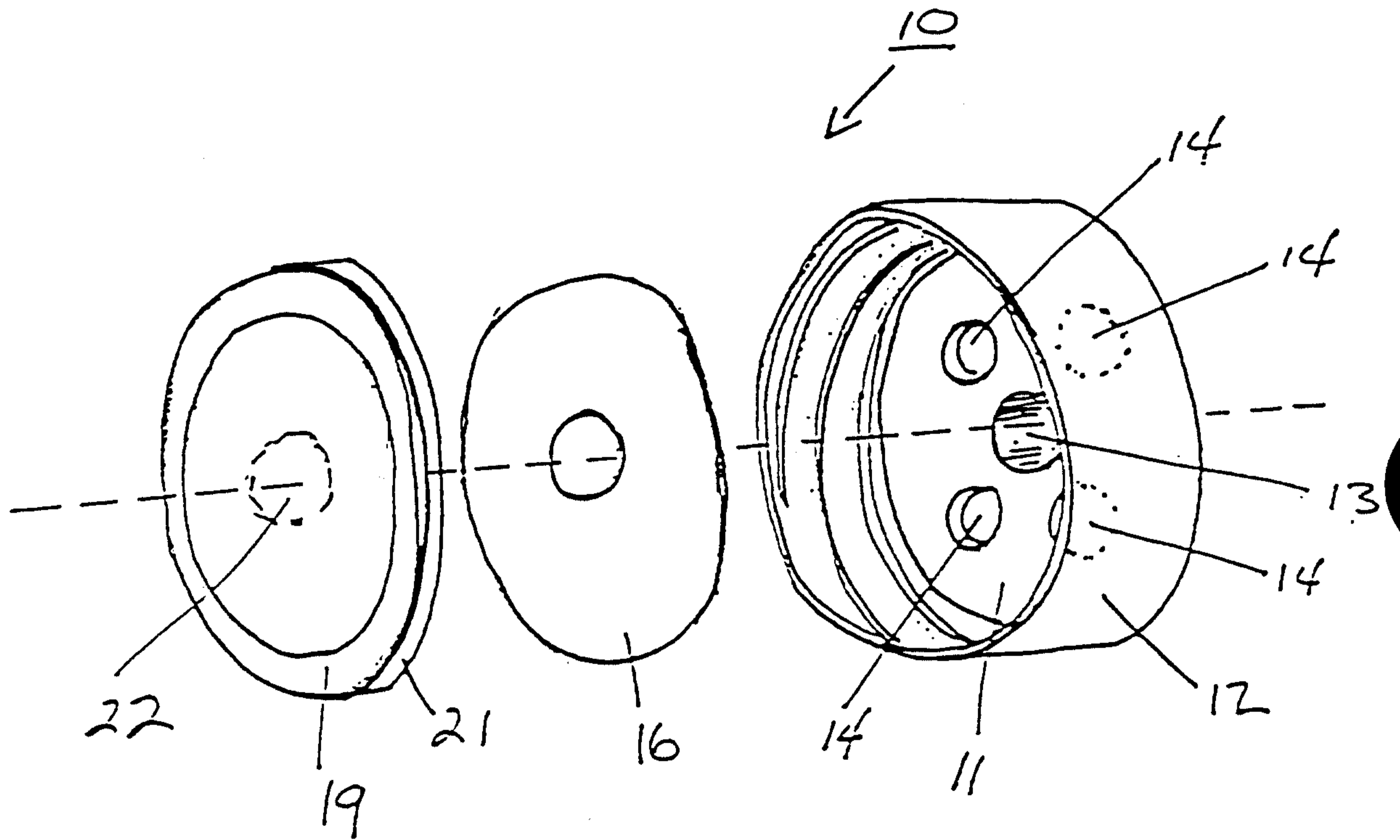

FIG. 1

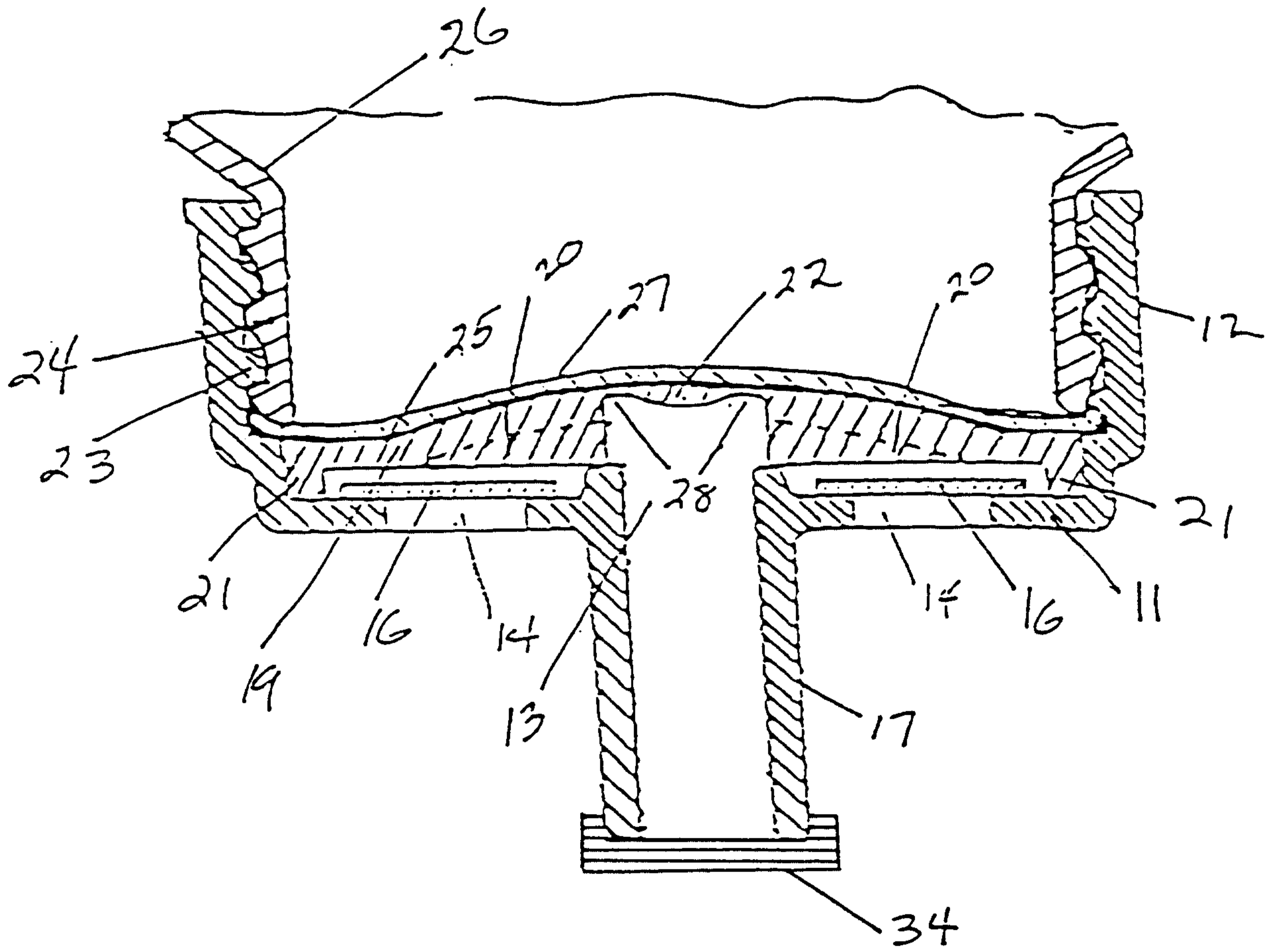

FIG. 2

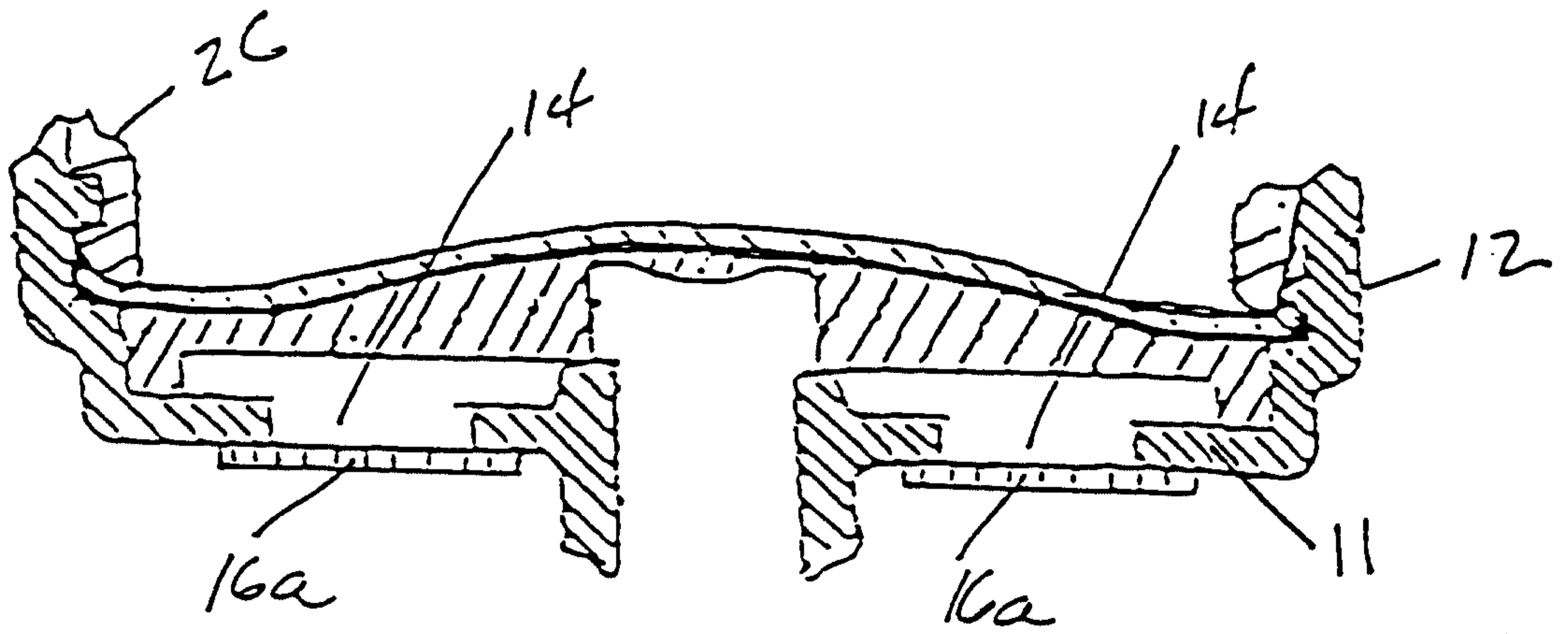

FIG. 3a

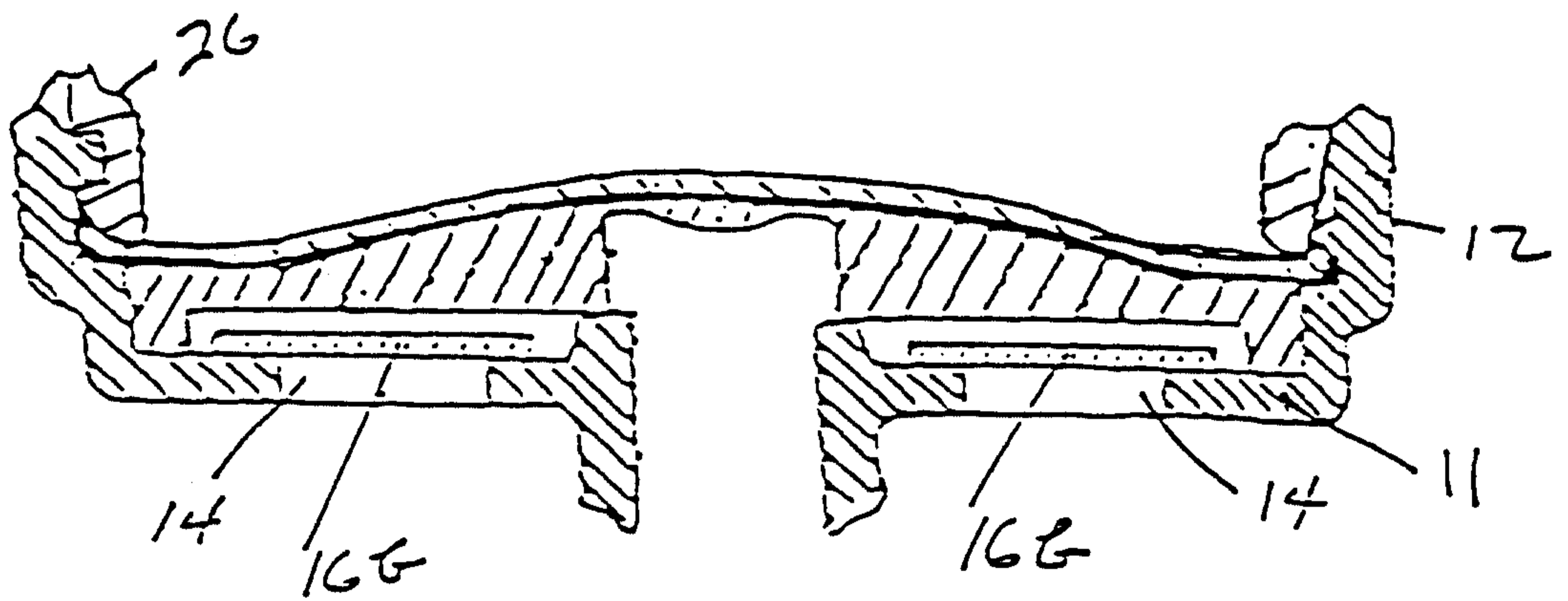

FIG. 3b

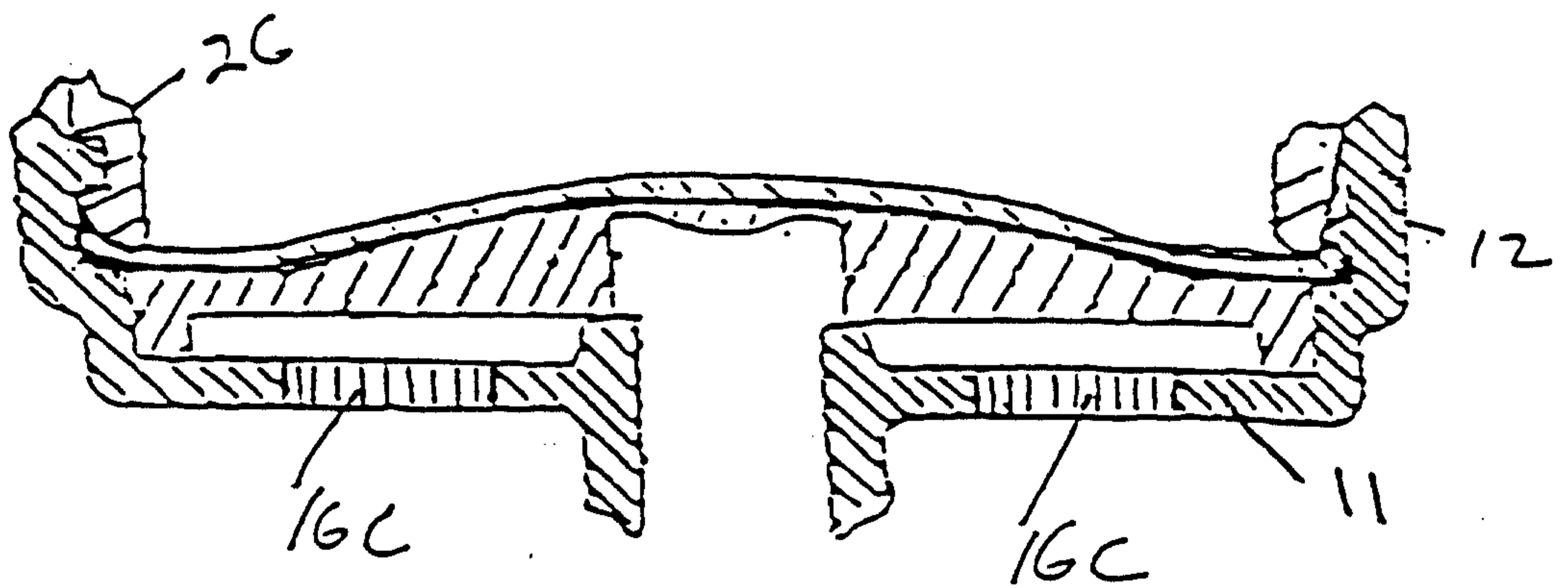

FIG. 3c

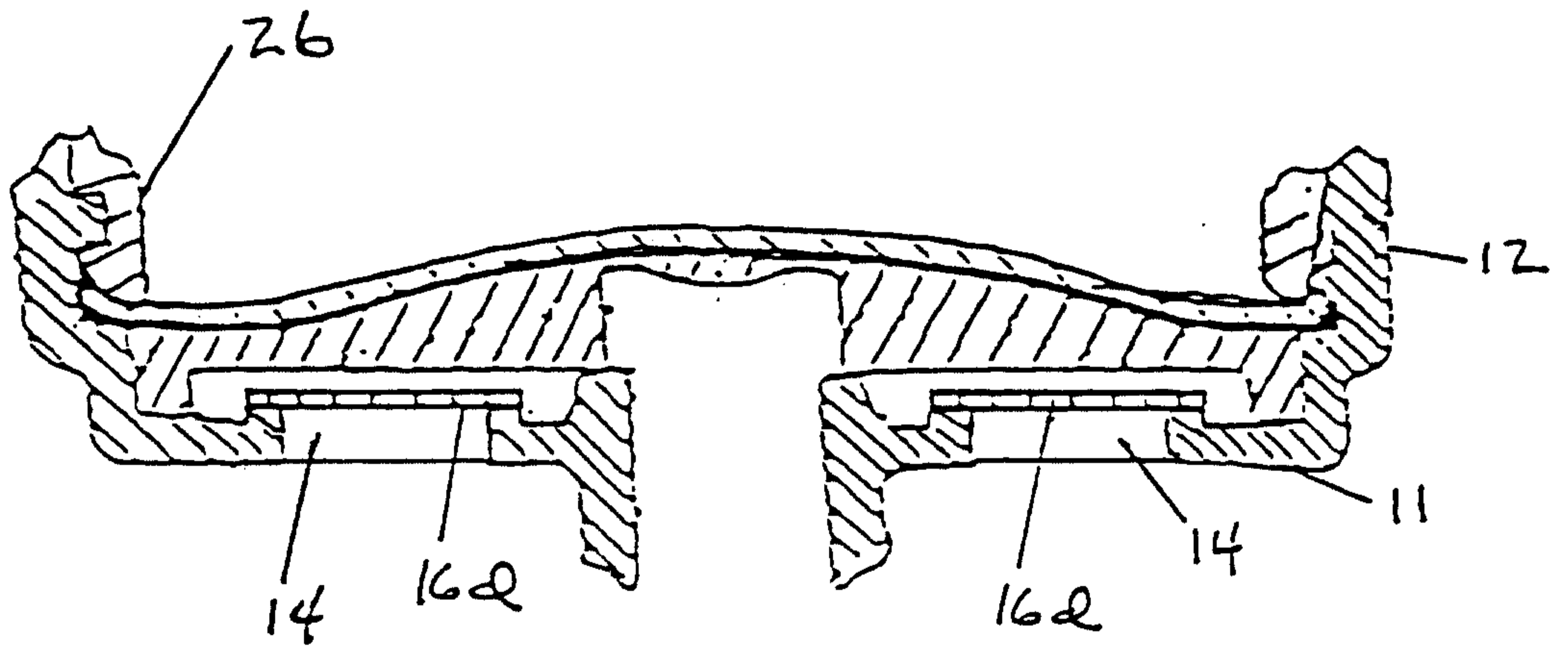

FIG. 3d

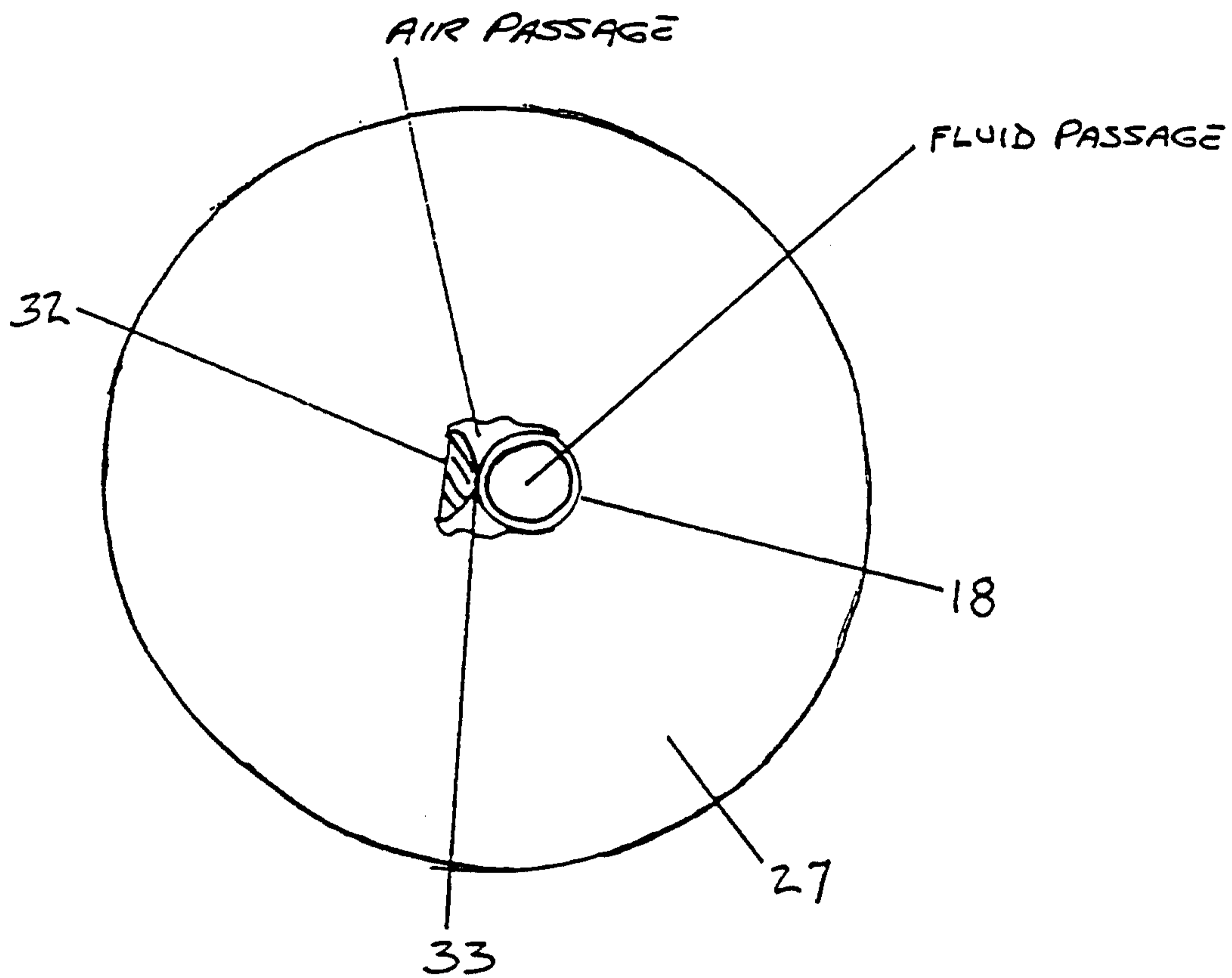

FIG. 7

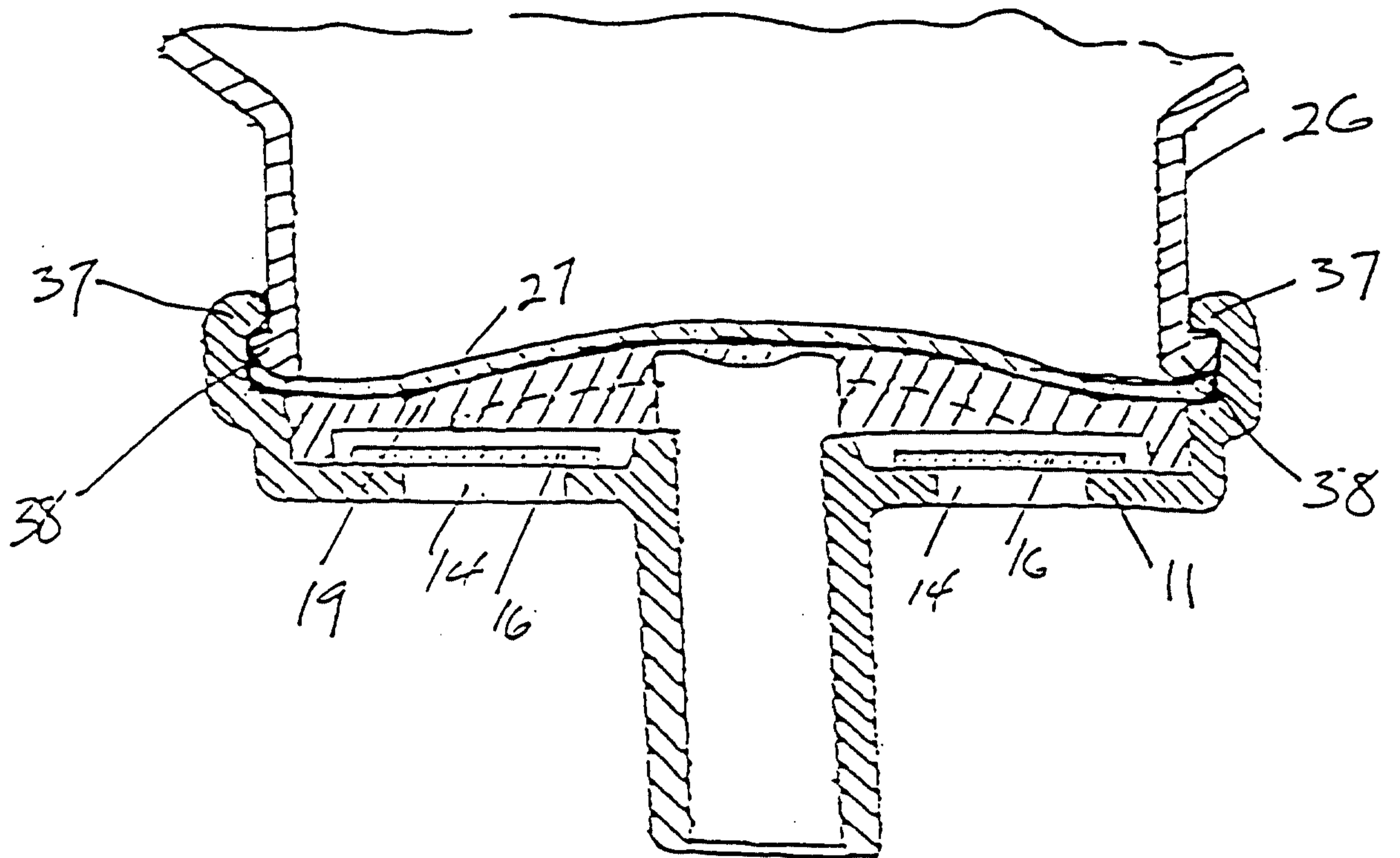

FIG. 8

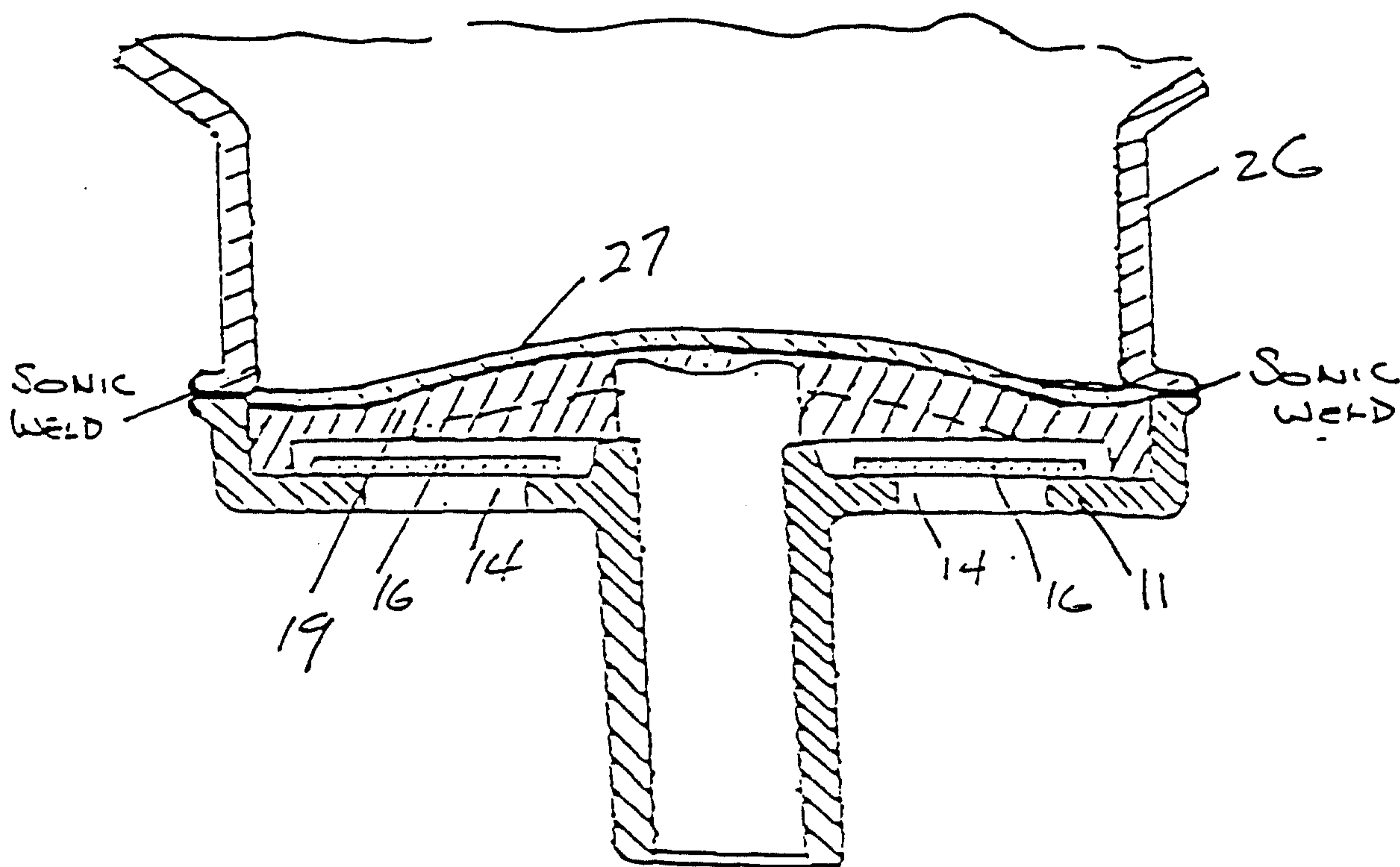

FIG. 9

