



US007745830B2

(12) **United States Patent**
Gu et al.

(10) **Patent No.:** **US 7,745,830 B2**
(45) **Date of Patent:** **Jun. 29, 2010**

(54) **LCD WITH INCREASED PIXEL OPENING SIZES**

4,731,610 A 3/1988 Baron et al.

(75) Inventors: **Tieer Gu**, Troy, MI (US); **Willem den Boer**, Troy, MI (US)

(Continued)

(73) Assignee: **LG Display Co., Ltd.**, Seoul (KR)

FOREIGN PATENT DOCUMENTS

(*) Notice: Subject to any disclaimer, the term of this patent is extended or adjusted under 35 U.S.C. 154(b) by 0 days.

DK 41-40-180 A1 12/1992

(21) Appl. No.: **12/453,344**

(Continued)

(22) Filed: **May 7, 2009**

OTHER PUBLICATIONS

(65) **Prior Publication Data**

US 2009/0256983 A1 Oct. 15, 2009

D. Perettie et al., "Benzocyclobutene as a Planarization Resin for Flat Panel Displays," Proceedings of the Spie, vol. 1665, Feb. 11-13, 1992, pp. 331-337.

Related U.S. Application Data

(Continued)

(63) Continuation of application No. 11/083,097, filed on Mar. 18, 2005, now Pat. No. 7,531,838, which is a continuation of application No. 10/052,767, filed on Jan. 23, 2002, now Pat. No. 6,870,188, which is a continuation of application No. 08/671,376, filed on Jun. 27, 1996, now Pat. No. 6,376,270, which is a continuation of application No. 08/470,271, filed on Jun. 6, 1995, now abandoned.

Primary Examiner—David S Blum

(74) *Attorney, Agent, or Firm*—McKenna Long & Aldridge

(51) **Int. Cl.**
H01L 31/0224 (2006.01)

(52) **U.S. Cl.** **257/72**; 257/E31.124; 349/42

(58) **Field of Classification Search** 257/72, 257/E31.124; 349/42

See application file for complete search history.

(57) **ABSTRACT**

A liquid crystal display having an increased pixel aperture ratio is disclosed along with a method of making same. An array of a-Si TFTs is deposited on a transparent substrate. Subsequently, an organic insulating layer (e.g. Benzocyclobutene) and a corresponding array of pixel electrodes are deposited over the TFT array so that the pixel electrodes overlap the display address lines thereby increasing the display's pixel aperture ratio. The low dielectric constant ϵ (e.g. about 2.7) and relatively high thickness (e.g. greater than about 1.5 μm) of the insulating layer reduce the pixel electrode-address line parasitic capacitance C_{PL} in the overlap areas thereby reducing cross-talk (or capacitive coupling) in the display. In sum, an increased pixel aperture ratio is achieved without sacrificing display performance.

(56) **References Cited**

U.S. PATENT DOCUMENTS

- 4,431,272 A 2/1984 Yazawa et al.
- 4,451,525 A 5/1984 Kawazoe et al.
- 4,636,038 A 1/1987 Kitahara et al.
- 4,672,454 A 6/1987 Cannella et al.
- 4,728,802 A 3/1988 Baron

17 Claims, 7 Drawing Sheets

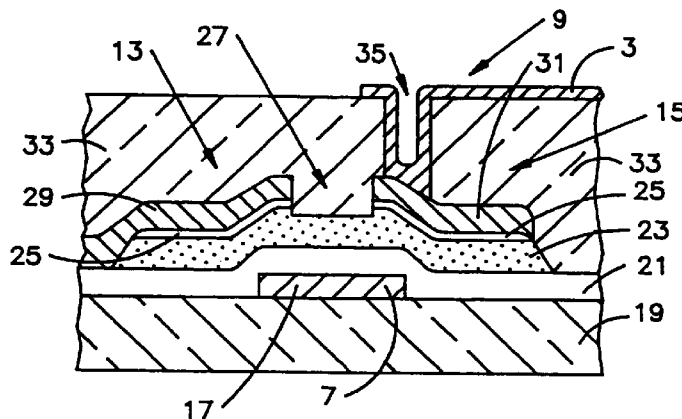

U.S. PATENT DOCUMENTS

4,868,616 A 9/1989 Johnson et al.
 4,943,838 A 7/1990 Ukai
 4,980,002 A 12/1990 Dzaroski, Jr. et al.
 5,003,356 A 3/1991 Wakai et al.
 5,045,905 A 9/1991 Motai et al.
 5,055,899 A 10/1991 Wakai et al.
 5,072,262 A 12/1991 Uekita et al.
 5,177,588 A 1/1993 Li et al.
 5,229,644 A 7/1993 Wakai et al.
 5,246,782 A 9/1993 Kennedy et al.
 5,281,546 A 1/1994 Possin et al.
 5,287,208 A 2/1994 Shimoto et al.
 5,294,820 A 3/1994 Gemma et al.
 5,302,987 A 4/1994 Kanemori et al.
 5,364,547 A 11/1994 Babb et al.
 5,396,072 A 3/1995 Schiebel et al.
 5,408,345 A 4/1995 Mitsui et al.
 5,409,777 A 4/1995 Kennedy et al.
 5,411,629 A 5/1995 Warfield
 5,414,278 A 5/1995 Kobayashi et al.
 5,459,596 A 10/1995 Ueda et al.
 5,463,230 A 10/1995 Negoto et al.
 5,463,483 A 10/1995 Yamazaki
 5,463,484 A 10/1995 Brody
 5,466,355 A 11/1995 Ohhashi et al.
 5,466,535 A 11/1995 Higgins et al.
 5,477,359 A 12/1995 Okazaki
 5,477,360 A 12/1995 Sunohara et al.
 5,483,366 A 1/1996 Atherton
 5,486,493 A 1/1996 Jeng
 5,498,880 A 3/1996 Lee et al.
 5,500,750 A 3/1996 Kanbe et al.
 5,527,592 A 6/1996 Afzali-Ardakani et al.
 5,528,209 A 6/1996 MacDonald et al.
 5,559,055 A 9/1996 Chang et al.
 5,576,630 A 11/1996 Fujita
 5,585,951 A 12/1996 Noda et al.
 5,591,676 A 1/1997 Hughes et al.
 5,600,458 A 2/1997 Okano et al.
 5,641,974 A 6/1997 Den Boer et al.
 5,661,050 A 8/1997 den Boer et al.
 5,675,187 A 10/1997 Numata et al.
 5,682,211 A 10/1997 Yao et al.
 5,708,483 A 1/1998 Asai
 5,721,596 A 2/1998 Kochi
 5,721,601 A 2/1998 Yamaji et al.
 5,724,111 A 3/1998 Mizobata et al.
 5,734,455 A 3/1998 Yoshida et al.
 5,770,871 A 6/1998 Weisfield
 5,780,871 A 7/1998 den Boer et al.
 5,780,874 A 7/1998 Kudo
 5,821,621 A 10/1998 Jeng
 5,844,647 A 12/1998 Maruno et al.
 5,847,720 A 12/1998 Dunand
 5,872,370 A 2/1999 Gu et al.
 5,917,563 A 6/1999 Matsushima
 5,920,084 A 7/1999 Gu et al.
 5,955,744 A 9/1999 Gu et al.
 5,994,157 A 11/1999 Aggas et al.
 5,994,721 A 11/1999 Zhong et al.
 6,011,274 A 1/2000 Gu et al.
 6,038,008 A 3/2000 Kim et al.
 6,100,954 A 8/2000 Kim et al.

FOREIGN PATENT DOCUMENTS

EP 0-486-047 A3 5/1992
 EP 486-047 A2 5/1992
 EP 0 490 335 A2 6/1992
 EP 0-536-898 A1 4/1993
 EP 0-589-478 A2 3/1994

EP 0-589-478 A3 3/1994
 EP 0 603 866 A1 6/1994
 EP 0-616-241 A2 9/1994
 EP 0-714-140 A1 5/1996
 GB 2-311-653 10/1997
 JP 62-036687 2/1987
 JP 63-279228 11/1988
 JP 63-289965 11/1988
 JP 02308226 A 12/1990
 JP 04-068318 3/1992
 JP 04-086047 5/1992
 JP 04-163528 6/1992
 JP 04-257826 6/1992
 JP 04199029 A 7/1992
 JP 4-257826 A 9/1992
 JP 04268532 A 9/1992
 JP 04-307520 10/1992
 JP 41-40180 12/1992
 JP 05-036898 4/1993
 JP 05-203936 8/1993
 JP 05326636 A 12/1993
 JP 05326641 A 12/1993
 JP 05-089478 3/1994
 JP 06-107958 4/1994
 JP 06123873 A 5/1994
 JP 06123878 A 5/1994
 JP 0603866 6/1994
 JP 06208137 A 7/1994
 JP 6-235929 8/1994
 JP 06-016241 9/1994
 JP 06-242433 9/1994
 JP 6-258662 9/1994
 JP 07028093 A 1/1995
 JP 07128670 A 5/1995
 JP 07146491 A 6/1995
 JP 07-014140 5/1996
 JP 0762184 3/1997
 JP 02-311653 10/1997
 JP 10-133165 5/1998

OTHER PUBLICATIONS

Abstract of Japanese Patent Publication No. 06242467, dated Sep. 2, 1994.
 Abstract of Japanese Patent Publication No. 02196221, dated Aug. 2, 1990.
 Abstract of Japanese Patent Publication No. 04163528; dated Jun. 9, 1992.
 Abstract of Japanese Patent Publication No. 04291240; dated Oct. 15, 1992.
 Abstract of Japanese Patent Publication No. 03242625, dated Oct. 29, 1991.
 M.J. Radler et al., Cyclotene Advanced Electronics Resins for High-Aperture AMLCD.; SID 96 Applications Digest, pp. 33-36 (1996).
 Eric P. Finchem et al., *A Multi-Level High Density Interconnect Process Designed & Developed for Manufacturability*, TriQuint Semiconductor, Inc., Beaverton, OR, USA.
 M.J. Radler et al., *Benzocyclobutene Dielectric Resins for Flat Panel Display Applications*, Proceedings of the 3rd Annual Display Manufacturing Technology Conference, pp. 123-124, 1996 (Conference date: Feb. 6-8, 1996).
 Stanley Wolf et al., *Silicon Processing for the VLSI Era*, vol. 1, Process Technology, Lattice Press, Sunset Beach, CA., 1986.
 Tadanori Shimoto et al. *High Density Multilayer Substrate Using Benzocyclobutene Dielectric*, IMC 1992 Proceedings, Yokohama, Jun. 3-5, 1992, pp. 325-330.
 Willem den Boer et al., *High Aperture TFT LCD using Polymer Interlevel Dielectric*, OIS Optical Imaging Systems, Inc., Northville, MI, USA.
 M.W. Friends, *Determination of Dielectric Constant for Fuji Clear*, Mar. 7, 1996, pp. 1-2, including Table.
 Willem den Boer, *A Two-Diode Pixel Circuit and Addressing Method for MIM LCDs*, OIS Optical Systems, Inc., Northville, MI, USA.

Tech Notes, Advanced Electronics Resins, *Processing Guide for Photo-Imageable BCB*, Dow Chemical Co., pp. 1-4.

Michael Schier, *Reactive Ion Etching of Benzocyclobutene Using a Silicon Nitride Dielectric Etch Mask*, J. Electrochem. Soc., vol. 142, No. 9, Sep. 1995, pp. 3238-3240.

Donald Peretrie, et al., *Benzocyclobutene as a Planarization Resin for Flat Panel Displays*, SPIE Vo., 1965, Liquid Crystal Materials, Device, and Applications (1992), pp. 331-337.

Wolf et al., "Silicon Processing for the VLSI Era", vol. 1, pp. 407-408, 418-421, 428-429, 1986.

"A Multi-Level High Density Interconnect Process Designed & Developed for Manufacturability" by Finchem, et. al.

"Reactive Ion Etching of Benzocyclobutene Using a Silicon Nitride Dielectric Etch Mask" by Schier, J. Electrochem Soc., vol. 142, No. 9, Sep. 1995.

"High Density Multilayer Substrate Using Benzocyclobutene Dielectric" by Shimoto, et al., IMC 1992 Proceedings, Yokohama, Jun. 3-5, 1992.

"Optimization of Very Small Pitch Active Matrix LCD for Projection" by Vignolle, et. al., IEEE, 1991.

"A High-Aperture-Ratio 3-In.-Diagonal YGA a-Si Light Valve with Pixel/Data and Pixel/Gate Lines Overlapping" by Sakamoto, et al. SID 1996 Digest.

"High Aperture and Fault-Tolerant Pixel Structure for TFT-LCDs" by Kim, et al. SID 1995 Digest.

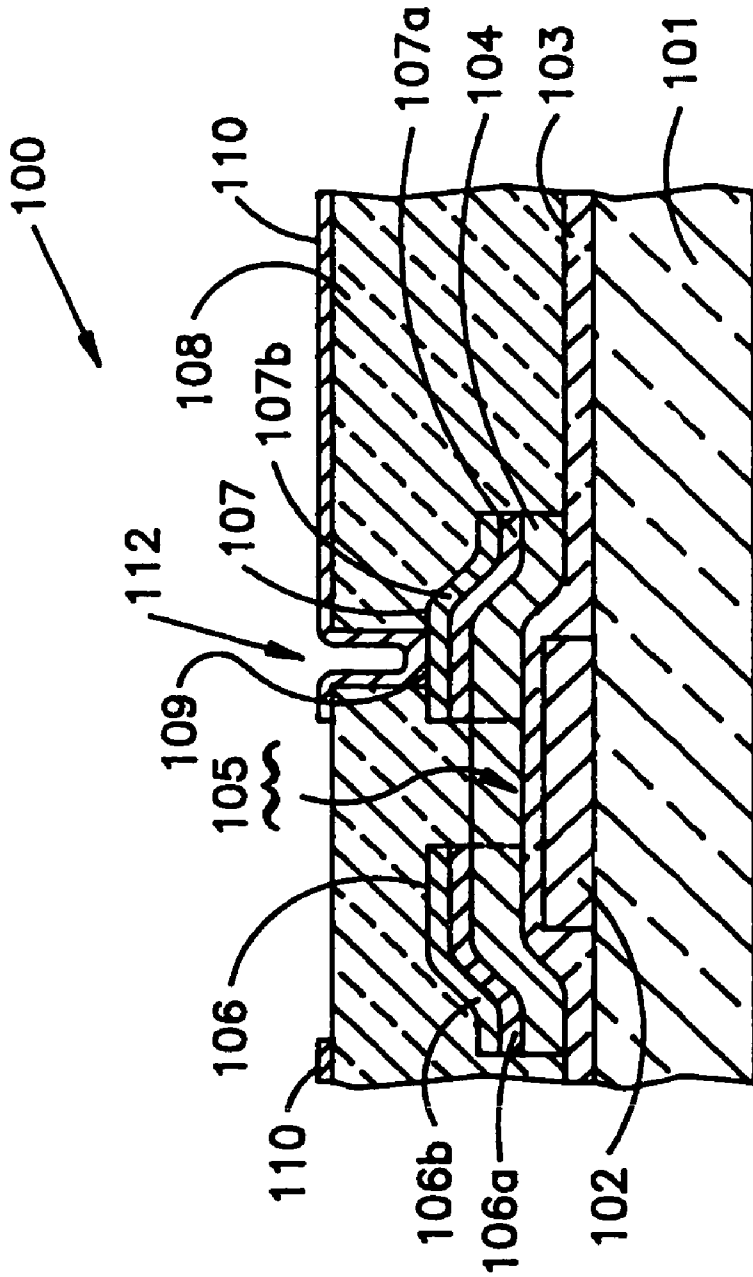

FIG. 1
(Prior Art)

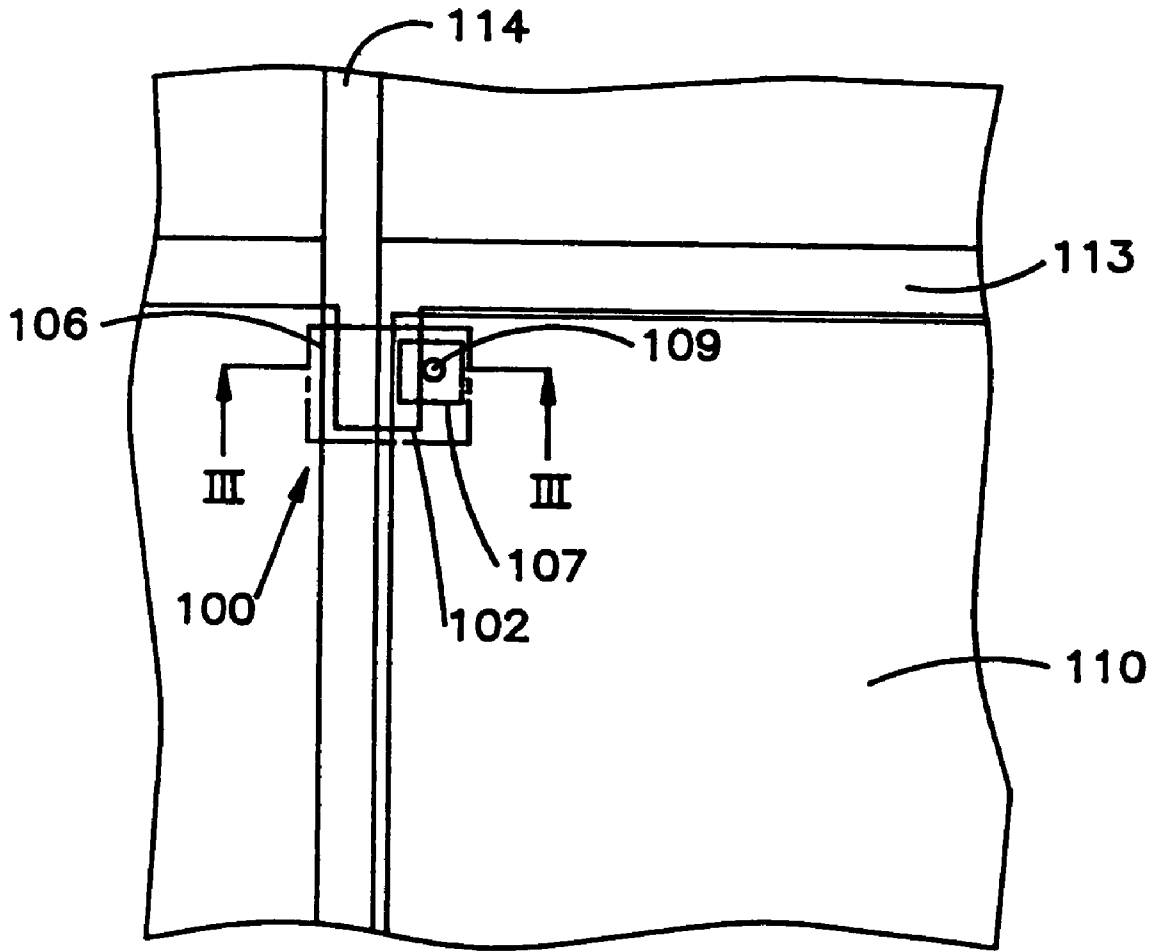

FIG. 2
(Prior Art)

FIG. 3

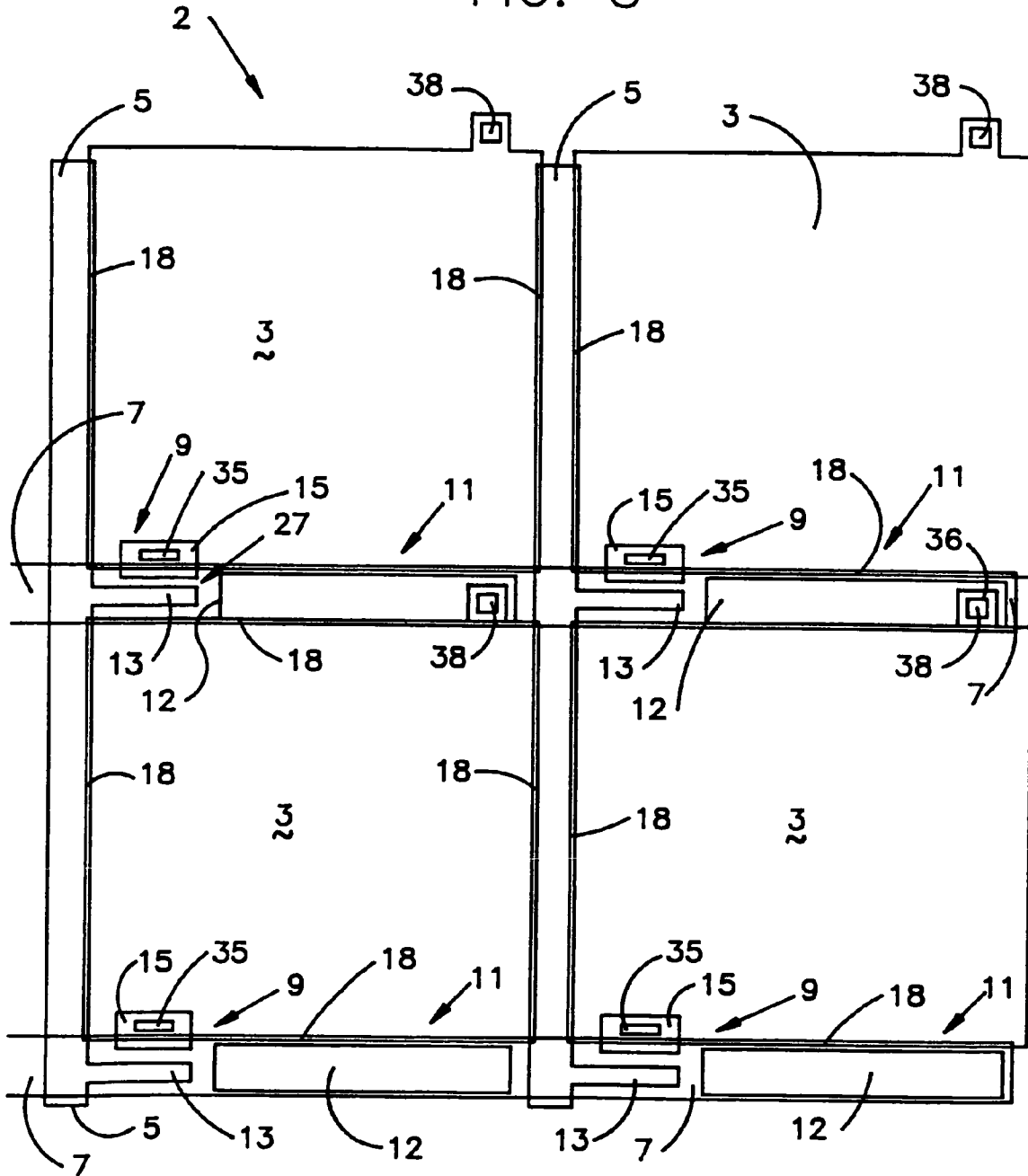

FIG. 4

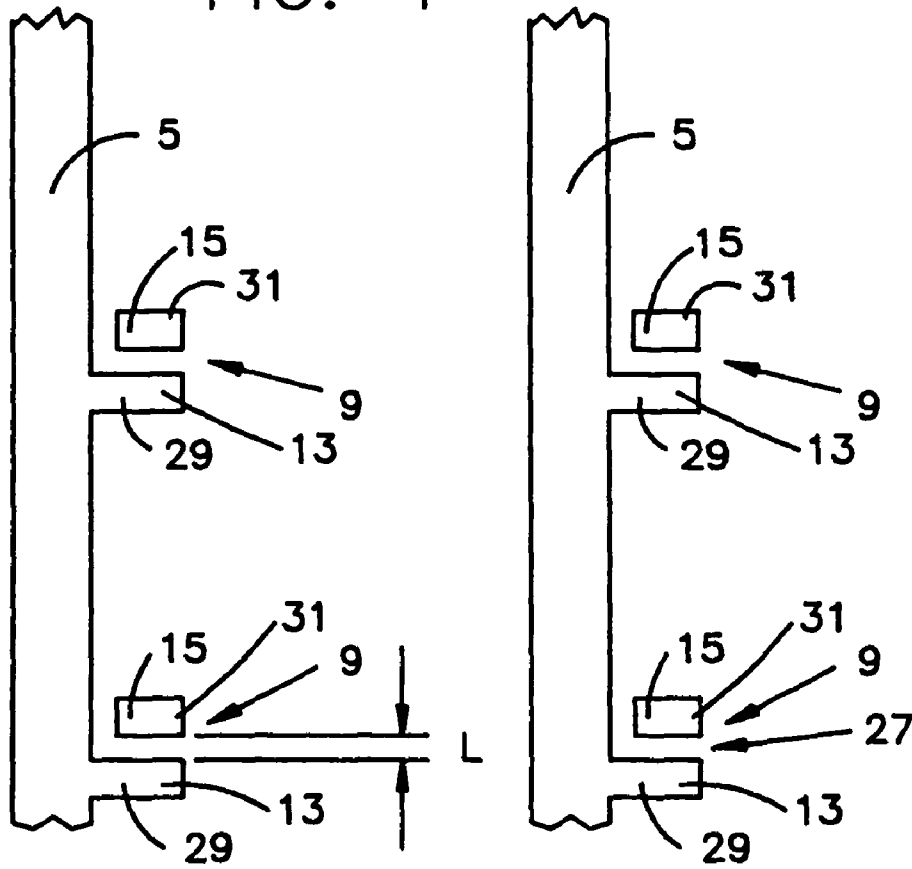

FIG. 5

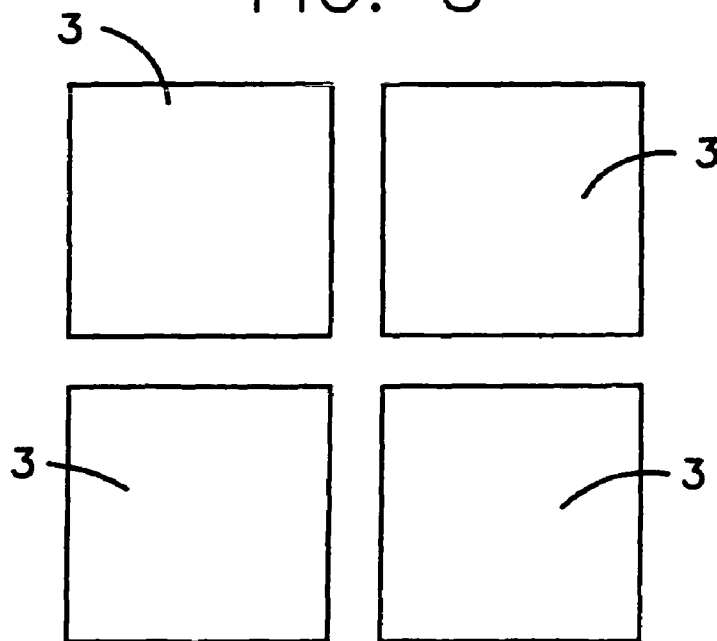

FIG. 6

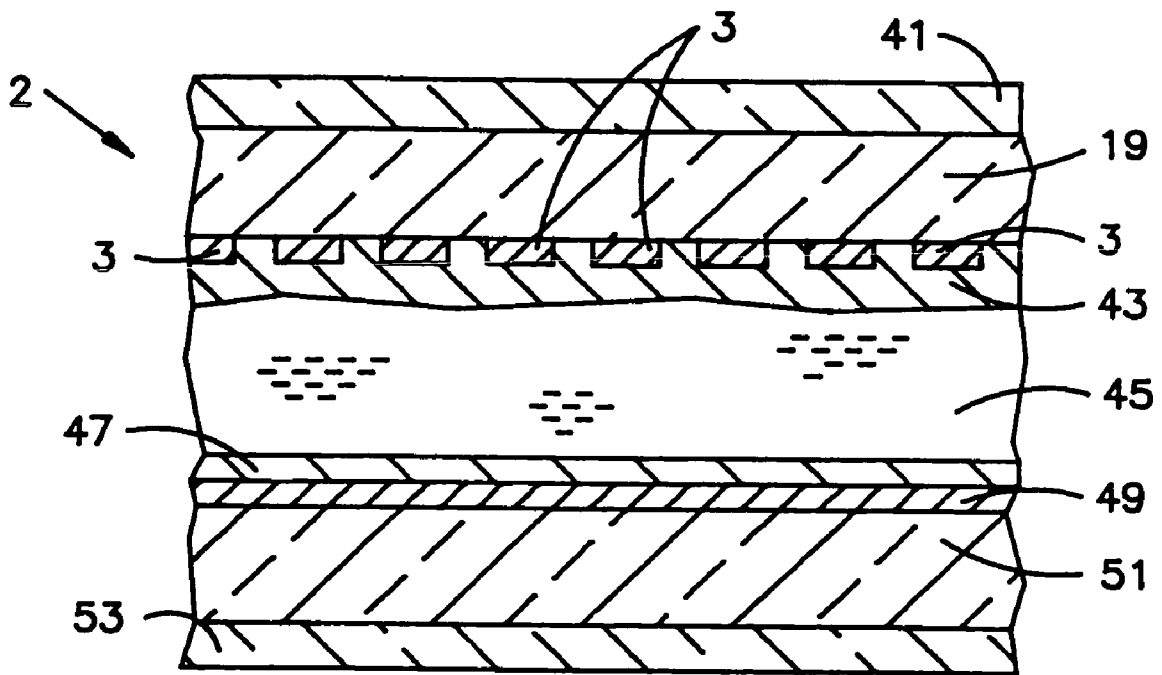
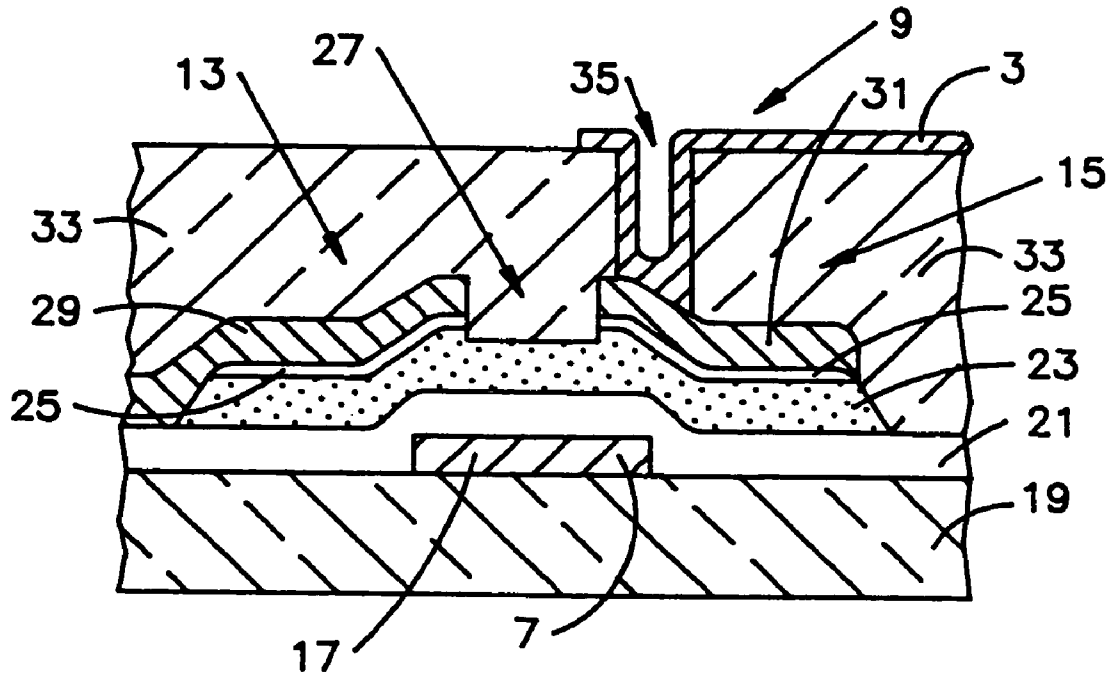
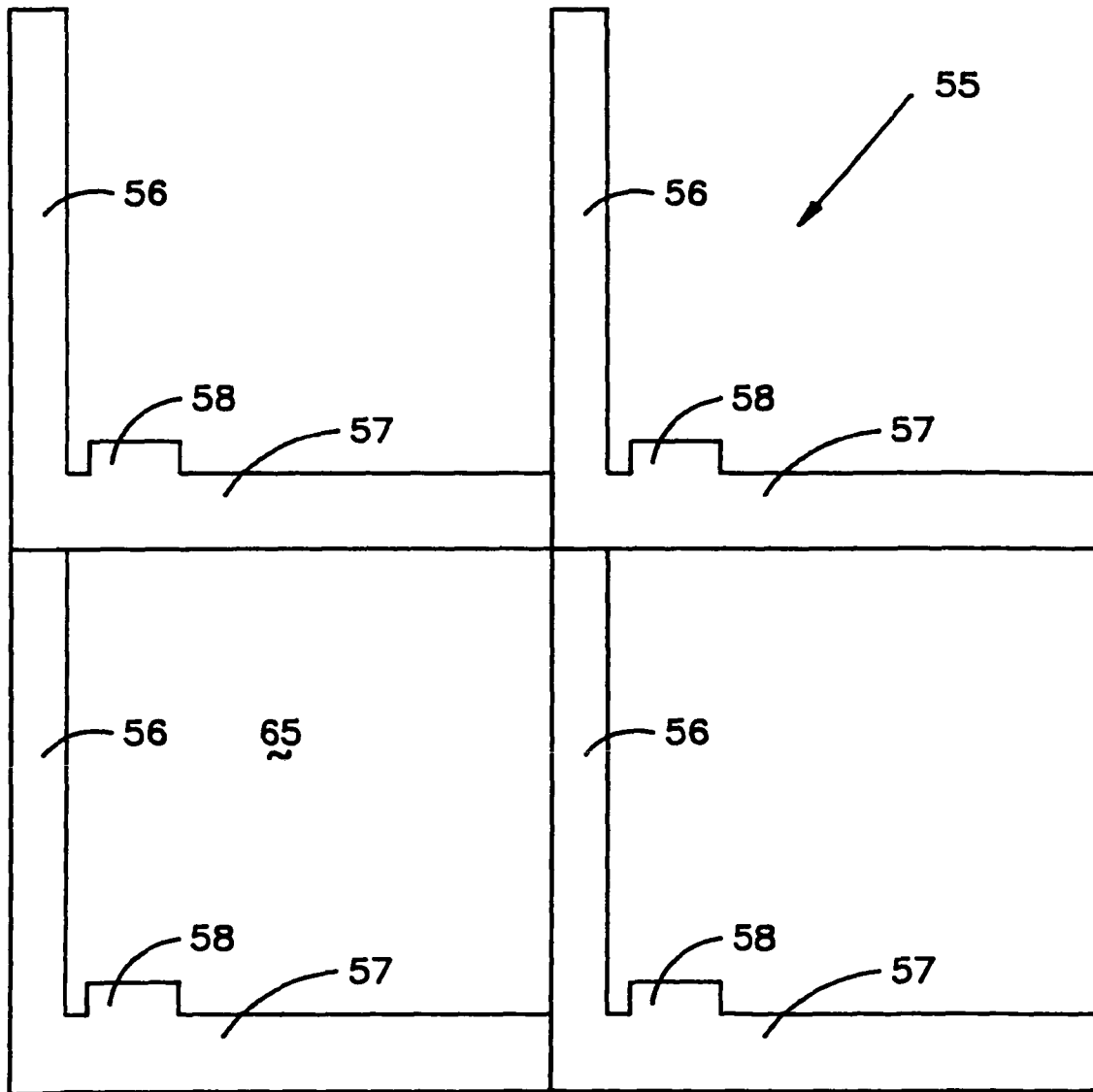

FIG. 7

FIG. 8



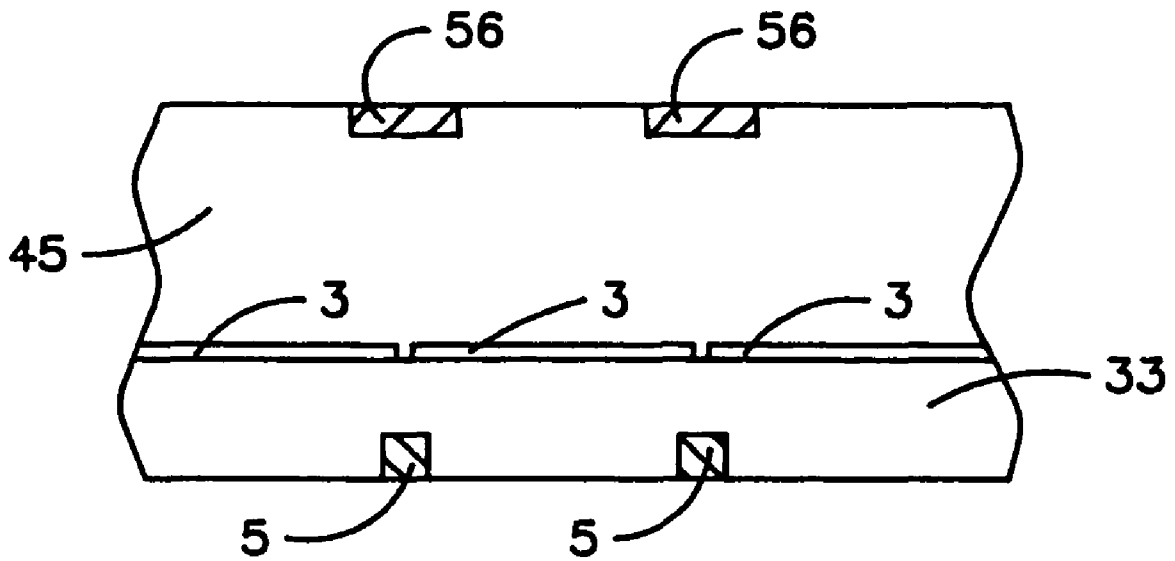

FIG. 9

LCD WITH INCREASED PIXEL OPENING SIZES

This application is a continuation of U.S. patent application Ser. No. 11/083,097, filed on Mar. 18, 2005, now U.S. Pat. No. 7,531,838 which is a continuation of U.S. patent application Ser. 10/052,767, filed Jan. 23, 2002, now U.S. Pat. No. 6,870,188, issued on Mar. 22, 2005, which is a continuation of U.S. patent application Ser. No. 08/671,376, filed Jun. 27, 1996, now U.S. Pat. No. 6,376,270, issued on Apr. 23, 2002, which is a continuation of U.S. patent application Ser. No. 08/470,271 filed on Jun. 6, 1995, now abandoned all of which are hereby incorporated by reference in their entirety for all purposes as is set forth herein.

This invention relates to a liquid crystal display (LCD) having an increased pixel aperture ratio. More particularly, this invention relates to a liquid crystal display including an array of TFTs (and method of making same) wherein an insulating layer having a plurality of contact vias or apertures etched therein is disposed between the TFTs and the pixel electrodes so that the pixel electrodes of the display are permitted to overlap the row and column address lines without exposing the display to capacitive cross-talk.

BACKGROUND OF THE INVENTION

Active matrix liquid crystal display (AMLCD) devices are typically composed of a matrix of liquid crystal pixels arranged horizontally in rows and vertically in columns. Such devices typically include first and second opposing polarizers, a liquid crystal layer disposed between the polarizers, and substantially transparent electrodes mounted on opposite sides of the liquid crystal (LC) layer so as to selectively energize same in order to create an image for a viewer.

Electronic matrix arrays find considerable applications in AMLCDs. Such AMLCDs generally include X and Y (or row and column) address lines which are horizontally and vertically spaced apart and cross at an angle to one another thereby forming a plurality of crossover points. Associated with each crossover point is an element (e.g. pixel) to be selectively addressed. These elements in many instances are liquid crystal display pixels or alternatively the memory cells of an electronically adjustable memory array.

Typically, a switching device such as a thin film transistor (TFT) is associated with each array element or pixel. The isolation device permit the individual pixels to be selectively addressed by the application of suitable potentials between respective pairs of the X and Y address lines. Thus, the TFTs act as switching elements for energizing corresponding pixel electrodes.

Amorphous silicon (a-Si) TFTs have found wide usage for isolation devices in LCD arrays. Structurally, TFTs generally include substantially co-planar source and drain electrodes, a semiconductor material (e.g. a-Si) disposed between the source and drain electrodes, and a gate electrode in proximity to the semiconductor but electrically insulated therefrom by a gate insulator. Current flow through the TFT between the source and drain is controlled by the application of voltage to the gate electrode. The voltage to the gate electrode produces an electric field which accumulates a charged region near the semiconductor-gate insulator interface. This charged region forms a current conducting channel in the semiconductor through which current is conducted.

Typically, pixel aperture ratios (i.e. pixel openings) in non-overlapping AMLCDs are only about 50%. As a result, either display luminance is limited or backlight power consumption is excessive, thereby precluding or limiting use in portable

applications. Thus, it is known in the art that it is desirable to increase the pixel aperture ratio or pixel opening size of LCDs to as high a value as possible so as to circumvent these problems. The higher the pixel aperture ratio (or pixel opening size) of a display, the higher the display transmission. Thus, by increasing the pixel aperture ratio of a display, transmission may be increased using the same backlight power, or alternatively, the backlight power consumption may be reduced while maintaining the same display transmission.

Currently, a common way of making AMLCDs is to pattern the ITO pixel electrodes at a distance or gap of about 5-10 μm from the bus lines which results in the LC material in this gap area not being activatable. Thus, the black matrix is required on the passive plate to overlap the pixel electrodes by about 5-10 μm so as to avoid light leakage in these areas and to compensate for potential plate misalignment. Thus, there exists a need in the art to eliminate this problem while simultaneously increasing pixel size.

For example, "High-Aperture TFT Array Structures" by K. Suzuki discusses an LCD having an ITO shield plane configuration having a pixel aperture ratio of 40% and pixel electrodes which overlap signal bus lines. An ITO pattern in Suzuki located between the pixel electrodes and the signal lines functions as a ground plane so as to reduce coupling capacitance between the signal lines and the pixel electrode. Unfortunately, it is not always desirable to have a shield electrode disposed along the length of the signal lines as in Suzuki due to production and cost considerations. The disposition of the shield layer as described by Suzuki requires extra processing steps and thus presents yield problems. Accordingly, there exists a need in the art for a LCD with an increased pixel aperture ratio which does not require an ITO shield plane structure to be disposed between the signal lines and pixel electrode.

FIG. 1 is a side elevational cross-sectional view of prior art linear thin film transistor (TFT) **100** of U.S. Pat. No. 5,055, 899. A plurality of TFTs **100** are typically arranged on transparent insulating substrate **101** in the form of a matrix array as set forth in the '899 patent. Each TFT **100** includes gate electrode **102** connected to gate address line **113** (see FIG. 2) extending in the row direction, drain electrode **106** connected to drain line **114** extending in the column direction, and source electrode **107** connected to transparent pixel electrode **110** independently formed in the pixel area defined between the array of gate lines **113** and drain lines **114**. Pixel electrode **110** operates in conjunction with an opposing common electrode (not shown) on the other side of the liquid crystal layer (not shown) so as to selectively drive the pixel enabling the respective polarizers to transmit or absorb light rays in order to create an image for the viewer. A TFT electrode, to which a data signal is supplied, will be referred to hereinafter as a drain electrode, while the TFT electrode attached to the pixel electrode will be referred to as a source electrode.

More specifically, as shown in prior art FIGS. 1-2, gate electrode **102** of prior art TFT **100** is formed on clear substrate **101**. Gate insulating film **103**, made of silicon oxide, for example, is formed or deposited on substrate **101** over top of gate electrode **102**. Semiconductor film **104**, made of amorphous silicon (a-Si), for example, is deposited on substrate **101** over top of gate insulating film **103** and gate **102**. Drain and source electrodes **106** and **107** respectively are deposited on substrate **101** over top of layers **103** and **104**. The linear-shaped source and drain electrodes are separated from one another by a predetermined distance forming TFT channel **105**. Drain and source electrodes **106** and **107** respectively utilize doped a-Si contact layers **106a** and **107a** in combina-

tion with drain-source metal layers **106b** and **107b** so as to form electrical connections with semiconductor layer **104**.

Insulating film **108** is deposited on substrate **101** over the source and drain electrodes to a thickness falling within the range of 2,000 to 8,000 Å, preferably about 3,000 Å. Insulating layer **108** may be an organic insulating film obtained by spin-coating and baking polyimide or an acrylic resin, or a silicon oxide inorganic insulating film (SOG film) obtained by spin-coating and baking a silanol compound. Subsequent to the deposition of insulating film **108** on the source and drain electrodes, vias **112** are formed in layer **108** for the purpose of allowing substantially transparent pixel electrodes **110** to contact source electrodes **107**. Thus, when a pixel electrode **110** is deposited and patterned over top of insulating layer **108**, a portion of it is formed in via **112** as shown in FIG. **1** so as to contact source **107** at point **109**. Pixel electrode **110** may be indium-tin-oxide (ITO), for example, and is sputtered on the surface of insulating layer **108** and in via **112** to a thickness of about 1,000 Å.

As can be seen in FIG. **2**, pixel electrode **110** in certain embodiments of the '899 patent is located completely within the confines of gate line **113** and drain line **114**. In other words, as illustrated in FIG. **2**, pixel electrode **110** does not overlap either of the address lines. However, it is stated in column 7 of the '899 patent that "transparent electrode **110** may be arranged so as to overlap the drain and gate lines **114** and **113**." It is further stated that "hence a maximum effective display area can be obtained . . . an opening ratio of 70% can be realized." In other words, the '899 patent discloses as an alternative embodiment forming pixel electrode **110** so that it overlaps address lines **113** and **114** for the purpose of increasing the pixel opening size or pixel aperture ratio of the AMLCD.

Unfortunately, if pixel electrode **110** of the '899 patent AMLCD is arranged so as to overlap address lines **113** and **114**, an undesirably high parasitic capacitance results in the overlap areas between pixel electrode **110** and the address lines. In other words, in the overlap areas, pixel electrode **110** forms a capacitor in combination with the overlapped address lines. The resulting parasitic capacitance C_{PL} between the pixel electrode **110** and the address lines in the overlap areas is defined as follows:

$$C_{PL} = \frac{(\epsilon \cdot \epsilon_0 \cdot A)}{d}$$

where "ε" is the dielectric constant of insulating layer **108**, "ε₀" is a constant value of 8.85×10⁻¹⁴ F/cm, "A" is the area of the resulting capacitor in the overlap area, and "d" is the thickness of insulating layer **108** in the overlap area.

Because of the above-referenced thin profile of insulating layer **108** in the '899 patent, the resulting parasitic capacitance C_{PL} created by the overlap is undesirably high thereby resulting in capacitive cross-talk in the LCD. Such cross-talk results when the signal voltage intended to be on a particular pixel is not there. Thus, when C_{PL} is too high, the voltage on the pixel is either higher or lower than intended depending upon how much voltage the other pixels on the signal address line received. In other words, the pixel is no longer satisfactorily isolated when C_{PL} is too high.

In view of the above with respect to the '899 patent, it is clear that there exists a need in the art for a liquid crystal display having both an increased pixel aperture ratio and reduced capacitive cross-talk in overlap areas so as to simultaneously properly isolate each pixel and increase the pixel

openings in order to allow the LCD to be easily used in portable applications with reduced power consumption.

Further with respect to U.S. Pat. No. 5,055,899, the disclosure of this patent does not appreciate the importance of the dielectric constant ε of insulating layer **108**. While referencing numerous materials including SiO₂ which may be used for layer **108**, the '899 patent does not discuss either the dielectric constant values ε of these materials or their importance in helping reduce C_{PL} in overlap areas. For example, the dielectric constant ε of SiO₂ (which the '899 patent states may be used as layer **108**) is undesirably high (about 3.9) thereby causing C_{PL} to be too high. When ε of the insulating layer is too high, capacitive cross-talk results in the display. In view of this, it is apparent that there exists a need in the art for an insulating layer to be disposed between the TFT electrodes (and address lines) and the pixel electrodes, this insulating layer having a dielectric constant value sufficient to reduce C_{PL} in overlap areas thereby substantially eliminating cross-talk problems in LCDs where the pixel electrodes overlap the address lines.

U.S. Pat. No. 5,182,620 discloses an AMLCD in which the pixel electrodes at least partially overlap the signal lines and an additional capacitor common line thereby achieving a larger numerical aperture for the display.

Unfortunately, the '620 patent suffers from at least the following problems. Firstly, the problems discussed above with respect to the '899 patent are all applicable to the '620 patent. Secondly, due to the additional capacitor common lines of the '620 patent, the pixel aperture ratio of the display is limited to about "48%". This is caused by the AMLCD design where the storage capacitor address lines are separate lines parallel to the column address lines thus resulting in reduced pixel aperture ratios. The AMLCD of the '620 patent uses the additional storage capacitor lines to suppress the effect of C_{PL} in the overlap area between the pixel electrode and the source. However, the presence of the additional storage capacitor lines is undesirable in that it reduces pixel aperture ratios and increases manufacturing costs.

Additional problems of the AMLCD of the '620 patent are that the pixel aperture ratio is not as great as would otherwise be desired in view of the fact that the pixel electrode does not overlap all address lines, and the required presence of three insulating layers.

It is apparent from the above that there exists a need in the art for an LCD having an increased pixel aperture ratio and substantially no capacitive cross-talk problems which is commercially feasible to manufacture, and a method of making same. Additionally, there exists a need in the art for a TFT and method of making same for implementing the increased pixel aperture ratios and the virtual elimination of cross-talk problems into the display.

It is a purpose of this invention to fulfill the above-described needs in the art, as well as other needs which will become apparent to the skilled artisan from the following detailed description of this invention.

SUMMARY OF THE INVENTION

Generally speaking, this invention fulfills the above-described needs in the art by providing a liquid crystal display with a large pixel aperture ratio comprising:

a liquid crystal layer sandwiched between first and second substrates;

an array of thin film transistors (TFTs) and corresponding pixel electrodes mounted on the first substrate, each of the thin film transistors including a semiconductor layer, a gate electrode connected to a gate address line, a drain electrode

5

connected to a drain address line, and a source electrode connected to one of the corresponding pixel electrodes, and wherein the pixel electrode connected to the source electrode overlaps the gate and drain address lines along longitudinal edges thereof; and

a substantially continuous insulating layer having a dielectric constant ϵ no greater than about 3.0 disposed between the pixel electrode and the address lines in sufficient thickness so as to reduce capacitive cross-talk in the display by reducing the pixel electrode-address line parasitic capacitance C_{PL} in the areas of overlap.

This invention further fulfills the above-described needs in the art by providing a thin film transistor (TFT) structure comprising:

- a substantially transparent substrate;
- a gate electrode located on the substrate and adapted to be connected to a first address line;
- a semiconductor layer located on the substrate over the gate electrode;
- a drain electrode located on the substrate over the semiconductor layer and adapted to be connected to a second address line;

- a source electrode located on the substrate over the semiconductor layer and spaced from the drain electrode so as to define a transistor channel, the source electrode adapted to be electrically connected to a pixel electrode;

- and insulating layer located on the substrate over the source and drain electrodes, the insulating layer being of sufficient thickness "d" and having a sufficiently low dielectric constant value ϵ so that when the pixel electrode overlaps one of the first and second address lines, the resulting pixel electrode-address line parasitic capacitance C_{PL} is sufficiently low so as to substantially eliminate cross-talk.

This invention further fulfills the above-described needs in the art by providing a liquid crystal display comprising:

- a liquid crystal layer;
- a substantially transparent substrate adjacent the liquid crystal layer;
- an array of thin film transistors disposed on the substrate, the thin film transistors connected to address lines and acting as switching elements for energizing corresponding pixel electrodes;

- a substantially transparent planarization layer disposed on the array of transistors, the planarization layer being located between the pixel electrodes and the address lines; and

- wherein the planarization layer includes Benzocyclobutene (BCB) and has a dielectric constant of less than about 3.0.

This invention still further fulfills the above-described needs in the art by providing a method of making a liquid crystal display including an array of TFTs, the method comprising the steps of:

- providing a substantially transparent first substrate;
- disposing a gate metal layer on the first substrate and patterning an array of TFT gate electrodes and gate address lines therefrom;

- disposing a semiconductor layer on the first substrate over the gate electrodes and patterning the semiconductor layer to form TFT areas;

- disposing and patterning drain and source electrodes on the substrate over the semiconductor layer;

- providing drain address lines for addressing the drain electrodes;

- disposing a substantially continuous organic insulating layer on the substrate over the address lines and the drain and source electrodes to a thickness of at least about 1.5 μm ; and

6

disposing and patterning an array of substantially transparent pixel electrodes on the substrate over the insulating layer so that the pattern pixel electrodes overlap at least one of the gate and drain lines in order to increase the displays pixel aperture ratio.

This invention will now be described with reference to certain embodiments thereof as illustrated in the following drawings.

IN THE DRAWINGS

FIG. 1 is a side elevational cross-sectional view of a prior art linear TFT.

FIG. 2 is a top view of the prior art TFT of FIG. 1 connected to gate and drain address lines and a corresponding pixel electrode in a prior art LCD application.

FIG. 3 is a top view of an AMLCD according to this invention, this figure illustrating pixel electrodes overlapping surrounding row and column address lines along their respective lengths throughout the pixel area so as to increase the pixel aperture ratio of the display.

FIG. 4 is a top view of the column (or drain) address lines and corresponding drain electrodes of FIG. 3, this figure also illustrating the TFT source electrodes disposed adjacent the drain electrodes so as to define the TFT channels.

FIG. 5 is a top view of the pixel electrodes of FIG. 3.

FIG. 6 is a side elevational cross-sectional view of the linear-shaped thin film transistors (TFTs) of FIGS. 3-4.

FIG. 7 is a side elevational cross-sectional view of the liquid crystal display of FIG. 3.

FIG. 8 is a top or bottom view of the optional black matrix to be located on a substrate of the LCD of FIGS. 3-7, the black matrix to be located on the substrate not having the TFT array disposed thereon.

FIG. 9 is a side cross-sectional view of a portion of the LCD of FIGS. 3-8, this figure illustrating the pixel electrodes overlapping the column address lines.

DETAILED DESCRIPTION OF CERTAIN EMBODIMENTS OF THIS INVENTION

Referring now more particularly to the accompanying drawings in which like reference numerals indicate like parts throughout the several views.

FIG. 3 is a top view of four pixels in active matrix liquid crystal display (AMLCD) 2 according to an embodiment of this invention. This portion of the display includes pixel electrodes 3, drain address lines 5, gate address lines 7, thin film transistors (TFTs) 9, and auxiliary storage capacitors 11. Each storage capacitor 11 is defined on one side by a gate line 7 and on the other side by an independent storage capacitor electrode 12. Storage capacitor electrodes 12 are formed along with drain electrodes 13 so that no additional address line is needed for the storage capacitors. As shown, the longitudinally extending edges of each pixel electrode 3 overlap drain lines 5 and gate lines 7 respectively along the edges thereof so as to increase the pixel aperture ratio (or pixel opening size) of the LCD.

In the areas of overlap 18 between pixel electrodes 3 and address lines 5, 7, a pixel-line (PL) capacitor is defined by an electrode 3 on one side and the overlapped address line on the other. The dielectric disposed between the electrodes of these PL capacitors is planarization layer 33 (see FIG. 6). The parasitic capacitance C_{PL} of these capacitors is defined by the equation:

7

$$C_{PL} = \frac{\epsilon \cdot \epsilon_0 \cdot A}{d}$$

where “d” is the thickness of planarization layer **33**, ϵ is the dielectric constant of layer **33**, ϵ_0 is the constant 8.85×10^{-14} F/cm (permittivity in vacuum), and “A” is the area of the PL capacitor in overlap areas **18**. It is important that C_{PL} be no greater than about 0.01 pF for a display with a pixel pitch of about 150 μm (i.e. not greater than in a conventional non-overlapping display where silicon nitride is used as a passivation layer between the pixel electrodes and the address lines). When the pixel pitch is smaller, C_{PL} should be scaled to a lower value as well because overlap areas **18** are smaller. Additionally, the pixel aperture ratio of an LCD decreases as the pixel pitch decreases as is known in the art. As will be appreciated by those of skill in the art, the importance of an acceptable (i.e. low) C_{PL} value becomes greater the higher the resolution (or smaller the pixel pitch) of the LCD. The pixel pitch of AMLCD **2** may be from about 40 to 5,000 μm according to certain embodiments of this invention. The pixel pitch as known in the art is the distance between centers of adjacent pixels.

FIG. **4** is a top view of drain address lines **5** of AMLCD **2** showing how extensions of address lines **5** form drain electrodes **13** of TFTs **9**. Each TFT **9** of AMLCD **2** includes source electrode **15**, drain electrode **13**, and gate electrode **17**. Gate electrode **17** of each TFT **9** is formed by the corresponding gate address line **7** adjacent the TFT.

FIG. **5** is a top view illustrating pixel electrodes **3** (absent their extension portions **38**) of AMLCD **2** disposed in array form. FIGS. **4-5** are provided so that FIG. **3** may be more easily interpreted.

FIG. **6** is a side elevational cross-sectional view of a thin film transistor (TFT) **9** of AMLCD **2**. Each linear TFT **9** has a channel length “L” defined by the gap **27** between source electrode **15** and drain electrode **13**. Source electrode **15** is connected to pixel electrode **3** so as to permit TFT **9** to selectively energize a corresponding pixel in AMLCD **2** in order to provide image data to a viewer. Thus, each TFT **9** effectively functions as a switch for the corresponding LCD pixel and pixel electrode. An array of TFTs **9** is provided as illustrated in FIG. **3** for AMLCD **2**.

Each TFT **9** structure includes substantially transparent substrate **19** (e.g. made of glass), metal gate electrode **17**, gate insulating layer or film **21**, semiconductor layer **23** (e.g. intrinsic amorphous silicon), doped semiconductor contact layer **25**, drain electrode **13**, source electrode **15**, planarization layer **33**, and a pixel electrode **3**. TFT channel **27** is of length “L” is defined between source **15** and drain **13**.

As shown in FIG. **6**, drain electrode **13** is made up of drain metal layer **29** (e.g. Mo) which is deposited on substrate **19** over top of doped contact layer **25**. Contact film or layer **25** may be, for example, amorphous silicon doped with an impurity such as phosphorus (i.e. n+ a-Si) and is sandwiched between semiconductor layer **23** and drain metal layer **29**. Source electrode **15** includes doped semiconductor contact layer **25** and source metal layer **31**. Metal layers **29** and **31** may be of the same metal and are deposited and patterned together according to certain embodiments of this invention. Alternatively, layer **29** may be deposited and patterned separately from layer **31** so that drain metal layer is of one metal (e.g. Mo) and source metal layer **31** is of another (e.g. Cr).

Substantially transparent planarization or insulating layer **33** having a low dielectric constant (less than about 3.0) is

8

deposited on substrate **19** so as to cover TFTs **9** and address lines **5** and **7**. Layer **33** is continuous in the viewing area of the display except for vias formed to allow pixel electrodes **3** to contact the TFT source electrodes and the storage capacitor electrodes. Planarization layer **33** has a dielectric constant ϵ less than or equal to about 3.0 according to certain embodiments of this invention. In more preferred embodiments, layer **33** has a dielectric constant of about 2.7 and is made of Benzocyclobutene (BCB) for the purpose of reducing capacitive cross-talk (or capacitive coupling) between pixel electrodes **3** and the address lines in overlap areas **18**. In other words, layer **33** has a low dielectric constant (e.g. 2.7) and relatively large thickness for the specific purpose of reducing C_{PL} in overlap areas **18**. BCB (an organic material) is produced and is commercially available from Dow Chemical. Other known substantially transparent planarization layers used in the semiconductor and MCM industries may also be used as layer **33** according to alternative embodiments of this invention.

Following the deposition of passivation or planarization layer **33** on substrate **19** over top of TFTs **9** and address lines **5** and **7**, substantially transparent pixel electrodes **3** (made of indium-tin-oxide or ITO) are deposited and patterned over layer **33** on substrate **19**. Apertures or vias **35** are formed in passivation layer **33** adjacent source electrodes **15** so that the pixel electrodes **3** can contact the corresponding source metal layers **31** of TFTs **9** as illustrated in FIG. **6**. Auxiliary vias **36** (see FIG. **3**) are formed in layer **33** so that pixel electrodes **3** can contact storage capacitor electrodes **12** via pixel electrode extension areas **38**.

Planarization layer **33** is deposited on substrate **19** over the address lines, storage capacitors, and TFTs to a thickness “d” of at least about 1.5 μm in overlap areas **18**. In preferred embodiments, the thickness “d” of planarization layer **33** is from about 2 to 3 μm and layer **33** has a degree of planarization of at least about 90% so as to maintain a substantially constant liquid crystal layer thickness across AMLCD **2**. An advantage of using planarization layer **33** is that liquid crystal layer disclinations induced at pixel electrode **3** edges by the topography of TFTs **9**, storage capacitors, and address lines are substantially eliminated by planarization (i.e. no hills and valleys are present in the top surface of layer **33**). Thus, the thickness of the LC layer is substantially maintained and display functionality is improved because electrodes **3** are substantially flat because of the planarization of the surface of layer **33** adjacent the pixel electrodes **3**.

Because of the low dielectric constant ϵ and relatively high thickness “d” of planarization layer **33**, the capacitive cross-talk problems of the prior art resulting from overly high C_{PL} values are substantially reduced in areas **18** where pixel electrodes **3** overlap address lines **5** and **7**. Thus, because layer **33** (with its relatively low dielectric constant and high thickness) is disposed between pixel electrodes **3** and the overlapped address lines, the capacitive cross-talk problems of the prior art are substantially reduced or eliminated and increased pixel openings are achievable without sacrificing display performance (e.g. pixel isolation). Additionally, no extra processing steps are required to deposit layer **33** as described herein according to certain embodiments of this invention.

Pixel opening sizes or the pixel aperture ratio of AMLCD **2** is at least about 65% (preferably at least about 75%) according to certain embodiments of this invention when the pixel pitch is about 150 μm . This will, of course, vary depending upon the pixel pitch of the display (pixel pitches of from about 40-500 μm may be used). Pixel electrodes **3** overlap address lines **5** and **7** along the edges thereof as shown in FIG. **3** by an amount up to about 3 μm . In certain preferred embodiments of

this invention, the overlap **18** of electrodes **3** over the edges of address lines **5** and **7** is designed to be from about 2 to 3 μm , with the end result after overetching being at least about 0.5 μm . According to certain other embodiments of this invention, the amount of overlap may be designed to be from about 2-3 μm , with the resulting post-processing overlap being from about 0 to 2 μm . The overlap amount may be adjusted in accordance with different LCD applications and pixel pitch sizes as will be appreciated by those of skill in the art.

In fact in certain situations, after etching and processing, pixel electrodes **3** may not overlap the address lines at all according to certain embodiments of this invention, although some overlap **18** is preferred. When no overlap occurs, the parasitic capacitance C_{PL} between the address lines and the adjacent pixel electrode **3** is still minimized or reduced due to the low dielectric constant of layer **33**.

Referring now to FIGS. **3-6**, it will be described how AMLCD **2** including the array of pixel electrodes **3** and corresponding address lines and TFTs **9** is formed according to an embodiment of this invention. Firstly, substantially transparent substrate **19** is provided. Next, a gate metal layer (which results in gate electrodes **17** and lines **7**) is deposited on the top surface (surface to be closest to the LC layer) of substrate **19** to a thickness of from about 1,000-5,000 \AA , most preferably to a thickness of about 2,500 \AA . The gate metal is deposited by way of sputtering or vapor deposition. The gate metal may be of tantalum (Ta) according to certain embodiments of this invention. Insulating substrate **19** may be of glass, quartz, sapphire, or the like.

The structure including substrate **19** and the deposited gate metal is then photomasked to provide a mask pattern corresponding to the desired gate electrode **17** and gate address line **7** configuration. The upper surface of the gate metal is exposed in a window where the photoresist has not been retained.

The gate metal (e.g. Ta) layer is then dry etched (preferably using reactive ion etching) in order to pattern the gate metal layer in accordance with the retained photoresist pattern. To do this, the structure is mounted in a known reactive ion etching (RIE) apparatus which is then purged and evacuated in accordance with known RIE procedures and etchants. This etching of the gate metal layer is preferably carried out until the gate metal is removed in center areas of the windows and is then permitted to proceed for an additional time (e.g. 20 to 40 seconds) of overetching to ensure that the gate metal is entirely removed from within the windows. The result is gate address lines **7** (and gate electrodes **17**) being left on substrate **19** as illustrated in FIGS. **3** and **6**.

After gate address lines **7** (and therefore electrodes **17**) are deposited and patterned on top of substrate **19** in the above-described manner, gate insulating or dielectric layer **21** is deposited over substantially the entire substrate **19** preferably by plasma enhanced chemical vapor deposition (CVD) or some other process known to produce a high integrity dielectric. Gate insulating layer **21** is preferably silicon nitride (Si_3N_4) but may also be silicon dioxide or other known dielectrics. Silicon Nitride has a dielectric constant of about 6.4. Gate insulating layer **21** is deposited to a thickness of from about 2,000-3,000 \AA (preferably either about 2,000 \AA or 3,000 \AA) according to certain embodiments.

It is noted that after anodization (which is optional), gate Ta layer **17** which was deposited as the gate electrode and gate line layer (when originally about 2,500 \AA thick) is about 1,800 \AA thick and a newly created TaO layer is about 1,600 \AA . Anodization takes place after the gate line patterning and before further processing. Thus, gate insulating layer **21** over gate lines **7** and electrodes **17** is made up of both the anod-

ization created TaO layer and the silicon nitride layer. Other metals from which gate electrode **17** and address line layer **7** may be made include Cr, Al, titanium, tungsten, copper, and combinations thereof.

Next, after insulating layer **21** has been deposited, semiconductor (e.g. intrinsic a-Si) layer **23** is deposited on gate insulating layer **21** to a thickness of about 2,000 \AA . Semiconductor layer **23** may be from about 1,000 \AA to 4,000 \AA thick in certain embodiments of this invention. Then, doped (typically phosphorous doped, that is n+) amorphous silicon contact layer **25** is deposited over intrinsic a-Si layer **23** in a known manner to a thickness of, for example, about 500 \AA . Doped contact layer **25** may be from about 200 \AA to 1,000 \AA thick according to certain embodiments of this invention.

Gate insulating layer **21**, semiconductor layer **23** and semiconductor contact layer **25** may all be deposited on substrate **19** in the same deposition chamber without breaking the vacuum according to certain embodiments of this invention. When this is done, the plasma discharge in the deposition chamber is stopped after the completion of the deposition of a particular layer (e.g. insulating layer **21**) until the proper gas composition for deposition of the next layer (e.g. semiconductor layer **23**) is established. Subsequently, the plasma discharge is re-established to deposit the next layer (e.g. semiconductor layer **23**). Alternatively, layers **21**, **23**, and **25** may be deposited in different chambers by any known method.

Thereafter, a source-drain metal layer (which results in drain metal layer **29** and source metal layer **31**) is deposited on substrate **19** over top of semiconductor layer **23** and contact layer **25**. This source-drain metal layer may be chromium (Cr) or molybdenum (Mo) according to certain embodiments of this invention. When chromium, the layer is deposited to a thickness of about 500-2,000 \AA , preferably about 1,000 \AA according to certain embodiments. When molybdenum, the layer is deposited to a thickness of from about 2,000 to 7,000 \AA , preferably about 5,000 \AA . The deposited source drain metal layer is then patterned (masked and etched) to form the source, drain, and storage capacitor electrodes.

Alternatively, a first metal layer may be deposited and patterned to form drain electrode portion **29** and storage capacitor electrode **12**, and a second metal layer may be deposited and patterned to form source electrode portion **31**. Thus, for example, source metal layer **31** may be chromium (Cr) while drain metal and storage capacitor electrode layer **29** is Mo according to certain embodiments of this invention. Other metals which may be used for the source and drain metals include titanium, Al, tungsten, tantalum, copper, or the like.

After patterning of source and drain portions **29** and **31**, contact layer **25** is etched in the channel **27** area and inevitably a bit of semiconductor layer **23** is etched along with it. The result is TFT **9** with channel **27** as shown in FIG. **6**.

Substantially transparent planarization or insulating layer **33** is then deposited over substantially the entire substrate **19** by way of spin-coating and curing in a nitrogen atmosphere according to certain embodiments of this invention. Planarization layer **33** fills recesses generated upon formation of TFTs **9** and flattens the surface above substrate **19** at least about 90% according to certain embodiments.

Vias or apertures **35** are then formed in planarization layer **33** over top of (or adjacent) each source metal layer **31** so as to permit the pixel electrodes **3** to electrically contact source electrodes **15** through these vias **35**. Simultaneously, vias **36** (see FIG. **3**) and lead openings adjacent the edges of the panel are formed in layer **33** over storage capacitor electrodes **12**.

After vias **35** and **36** are formed in layer **33**, a substantially transparent conducting layer (e.g. ITO) which results in pixel

electrodes **3** is deposited and patterned (photomasked and etched) on substrate **19** over top of planarization layer **33**. After patterning of this substantially transparent conducting layer, pixel electrodes **3** are left as shown in FIGS. **3** and **6**. As a result of vias **35** and **36** formed in layer **33**, each pixel electrode **3** contacts a source metal layer **31** as shown in FIG. **6** and contacts a storage capacitor electrode **12** as shown in FIG. **3**. The result is the active plate of FIGS. **3** and **6**. The pixel electrode layer (when made of ITO) is deposited to a thickness of from about 1,200 to 3,000 Å (preferably about 1,400 Å) according to certain embodiments of this invention. Other known materials may be used as pixel electrode layer **3**.

After formation of the active plate, liquid crystal layer **45** is disposed and sealed between the active plate and the passive plate as shown in FIG. **7**, the passive plate including substrate **51**, polarizer **53**, electrode **49**, and orientation film **47**.

As shown in FIG. **3**, pixel electrodes **3** are patterned to a size so that they overlap both drain address lines **5** and gate address lines **7** along the edges thereof so as to result in an increased pixel aperture ratio for AMLCD **2**. The cross-talk problems of the prior art are substantially eliminated due to the presence of layer **33** with its relatively high thickness and low dielectric constant disposed in overlap areas **18** between pixel electrodes **3** and the address lines.

FIG. **7** is a side elevational cross-sectional view of AMLCD **2** (absent the TFTs, address lines, and black matrix). As shown, the twisted nematic display includes from the rear forward toward the viewer, rear polarizer **41**, substantially transparent substrate **19**, pixel electrodes **3**, rear orientation film **43**, liquid crystal layer **45**, front orientation film **47**, common electrode **49**, front substantially transparent substrate **51**, and finally front polarizer **53**. Polarizers **41** and **53** may be arranged so that their transmission axes are either parallel or perpendicular to each other so as to define a normally black or normally white color AMLCD respectively. optionally, retarder(s) may also be provided.

Typically, a backlight is provided rearward of polarizer **41** so that light emitted therefrom first goes through polarizer **41**, then through liquid crystal layer **45** and finally out of front polarizer **53** toward the viewer. Pixel electrodes **3** selectively work in conjunction with common electrode **49** so as to selectively apply voltages across liquid crystal layer **45** so as to cause an image (preferably colored according to certain embodiments) to be viewed from the front of the display.

FIG. **8** illustrates an optional black matrix (BM) pattern **55** to be disposed on front substrate **51** for the purpose of overlapping address lines **5** and **7** and TFT channels **27**. When the ITO of the pixel electrodes **3** overlaps the address lines, the address lines themselves are effectively the black matrix blocking light in the interpixel areas. However, low reflectance black matrix **55** with a larger than normal opening is still useful on the top (or passive) plate in order to reduce specular reflectance and to prevent ambient light incidence on the TFT channels. Therefore, the pixel aperture ratio of the display can be made larger because the pixel electrode area is larger and the overlap between the pixel electrodes on the active plate and black matrix **55** on the passive plate can be reduced.

Black matrix structure **55** includes vertically extending regions **56** and horizontally extending regions **57**. Regions **56** are aligned with drain lines **5** while regions **57** are aligned with gate lines **7** so as to prevent ambient light from penetrating the display. Additionally, black matrix **55** includes channel covering portions **58** which are aligned with TFT channels **27** for the purpose of preventing ambient light from reaching amorphous silicon semiconductor layer **23** through the chan-

nels. As commonly known in the art, the pixel openings **65** of the display are substantially defined by black matrix regions **56** and **57**.

FIG. **9** is a side elevational cross-sectional view of a portion of AMLCD **2**. As shown, the central pixel electrode **3** illustrated in FIG. **9** overlaps both column or drain address lines **5** thereby increasing the pixel electrode size relative to that of many prior art displays. Also, black matrix portions **56** line up with address lines **5** so that the pixel aperture or opening for the center electrode **3** is defined by the distance between black matrix members **56**. Black matrix portions **56** and address lines **5** are both arranged so that their central axes correspond with the gaps between pixel electrodes **3** according to certain embodiments of this invention. The presence of layer **33** substantially reduces the parasitic capacitance of the capacitor created between pixel electrodes **3** and address lines **5** in the overlap areas **18** as set forth above.

Once given the above disclosure, many other features, modifications, and improvements will become apparent to the skilled artisan. Such other features, modifications, and improvements are, therefore, considered to be a part of this invention, the scope of which is to be determined by the following claims.

We claim:

1. A liquid crystal display comprising:

a liquid crystal layer between first and second substrates; a plurality of gate address lines and a plurality of data address lines crossing each other to define a plurality of pixel regions on the first substrate;

a thin film transistor and a pixel electrode in each pixel region, the thin film transistor including a semiconductor layer, a gate electrode connected to one of the plurality of gate address lines, a drain electrode connected to one of the plurality of data address lines, and a source electrode connected to the pixel electrode, the pixel electrode overlapping the gate and data address lines; and an insulating layer between the pixel electrode and the data address lines,

wherein $A/d < 418.5 \mu\text{m}$, where A is the area of a portion of where the pixel overlaps the gate and data address lines and d is a thickness of the insulating layer in the overlapping areas.

2. The liquid crystal display of claim 1, wherein $A/d < 376.6 \mu\text{m}$.

3. The liquid crystal display of claim 1, wherein the pixel electrode overlaps the gate and drain address lines along substantially their entire lengths so as to increase the pixel aperture ratio.

4. A liquid crystal display comprising:

a liquid crystal layer between first and second substrates; a plurality of gate address lines and a plurality of data address lines crossing each other to define a plurality of pixel regions on the first substrate;

a thin film transistor and a pixel electrode in each pixel region, the thin film transistor including a semiconductor layer, a gate electrode connected to one of the plurality of gate address lines, a drain electrode connected to one of the plurality of data address lines, and a source electrode connected to the pixel electrode, the pixel electrode overlapping the gate and data address lines; and an insulating layer between the pixel electrode and the data address lines,

wherein $A \in < 3389.8 \mu\text{m}^2$, where A is the area of a portion of where the pixel overlaps the gate and data address lines and \in is a dielectric constant of the insulating layer in the overlapping areas.

13

5. The liquid crystal display of claim 4, wherein $A < 2259.9 \mu\text{m}^2$.

6. The liquid crystal display of claim 4, wherein $A < 1694.9 \mu\text{m}^2$.

7. The liquid crystal display of claim 4, wherein $1694.9 \mu\text{m}^2 < A < 2259.9 \mu\text{m}^2$.

8. The liquid crystal display of claim 4, wherein the pixel electrode overlaps the gate and drain address lines along substantially their entire lengths so as to increase the pixel aperture ratio.

9. A liquid crystal display comprising:
 a liquid crystal layer between first and second substrates;
 a plurality of gate address lines and a plurality of data address lines crossing each other to define a plurality of pixel regions on the first substrate;
 a thin film transistor and a pixel electrode in each pixel region, the thin film transistor including a semiconductor layer, a gate electrode connected to one of the plurality of gate address lines, a drain electrode connected to one of the plurality of data address lines, and a source electrode connected to the pixel electrode, the pixel electrode overlapping the gate and data address lines; and

14

an insulating layer between the pixel electrode and the data address lines, wherein $A < 1255.5 \mu\text{m}^2$, where A is the area of a portion of where the pixel overlaps the gate.

10. The liquid crystal display of claim 9, wherein $A < 1129.9 \mu\text{m}^2$.

11. The liquid crystal display of claim 9, wherein $A < 837 \mu\text{m}^2$.

12. The liquid crystal display of claim 9, wherein $A < 753.3 \mu\text{m}^2$.

10 13. The liquid crystal display of claim 9, wherein $A < 627.7 \mu\text{m}^2$.

14. The liquid crystal display of claim 9, wherein $A < 565.0 \mu\text{m}^2$.

15 15. The liquid crystal display of claim 9, wherein $837 \mu\text{m}^2 < A < 1255.5 \mu\text{m}^2$.

16. The liquid crystal display of claim 9, wherein $753.3 \mu\text{m}^2 < A < 1129.9 \mu\text{m}^2$.

20 17. The liquid crystal display of claim 9, wherein the pixel electrode overlaps the gate and drain address lines along substantially their entire lengths so as to increase the pixel aperture ratio.

* * * * *