

P. YOE.

INDICATOR LOCK.

No. 274,875.

Patented Mar. 27, 1883.

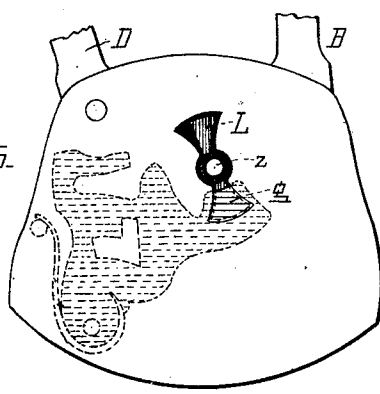
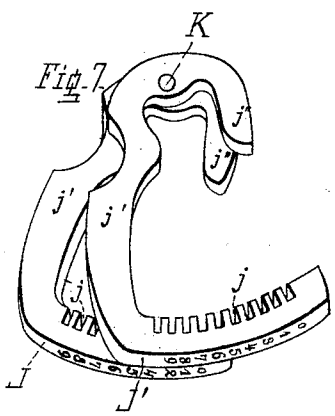
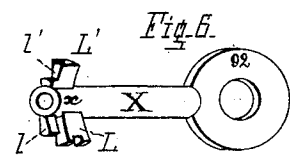
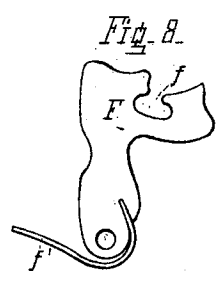
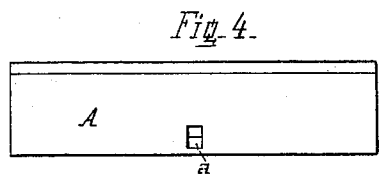
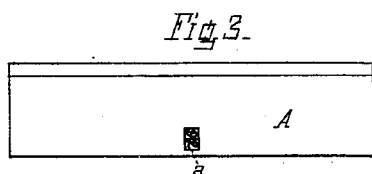
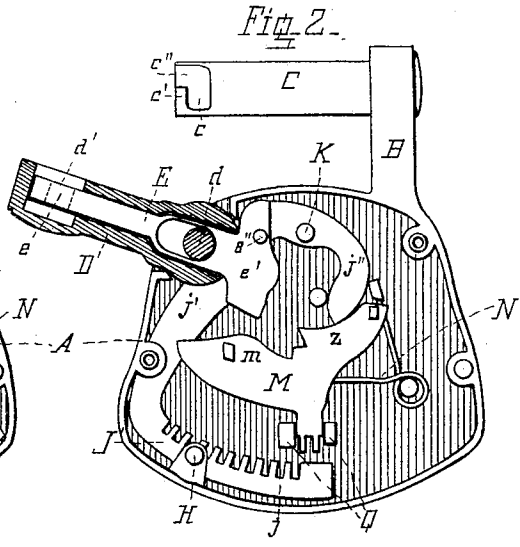
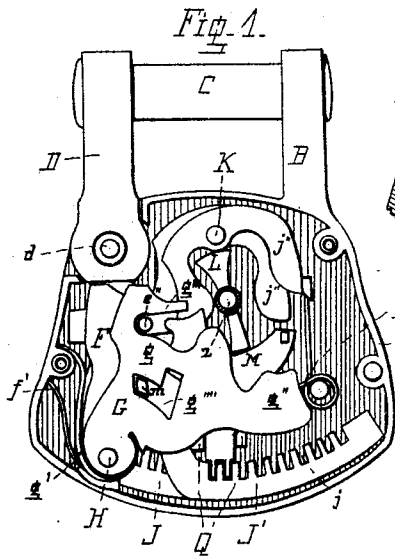

Attest
 Carl Spengel
Chas. J. Fayer.

Inventor
 Philip Yoe
 by Knight Bros.
 Atty's.

P. YOE.
INDICATOR LOCK.

No. 274,875.

Patented Mar. 27, 1883.

Fig. 9.

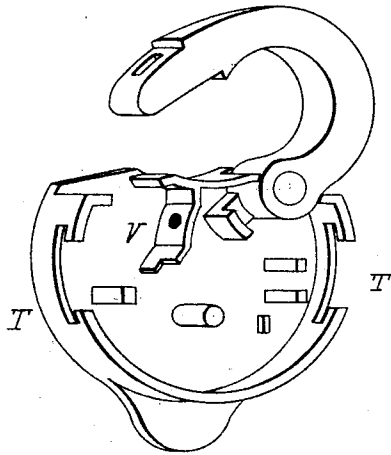

Fig. 10.

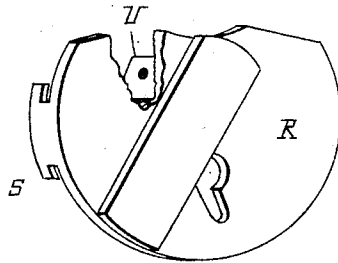
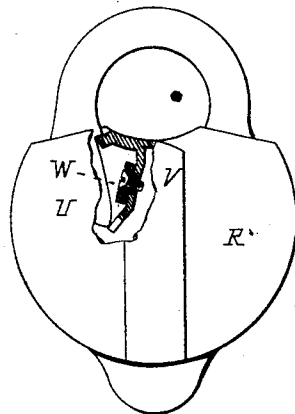

Fig. 11.



Attest.
Carl Spengel
Wm. J. Fayard

Inventor
Philip Yoe
by Knight Bros.
Atty's.

UNITED STATES PATENT OFFICE.

PHILIP YOE, OF CINCINNATI, OHIO, ASSIGNOR TO THE INDICATOR LOCK COMPANY, OF BLOOMINGTON, ILLINOIS.

INDICATOR-LOCK.

SPECIFICATION forming part of Letters Patent No. 274,875, dated March 27, 1883.

Application filed August 25, 1882. (Model.)

To all whom it may concern:

Be it known that I, PHILIP YOE, of Cincinnati, Hamilton county, Ohio, have invented new and useful Improvements in Indicator-Locks, of which the following is a specification.

My invention relates to improvements in locks such as described in Reissued Patent No. 9,300, granted, July 13, 1880, to the Russell Indicator Lock Company, in which a single lock designed to be controlled by several persons is provided with mechanism which indicates by specific arrangements of numbered tablets by which one of a given set or series of keys the lock was last unlocked.

My improvements are designed to secure a more positive, certain, and invariable operation of the indicator-tablets with any particular key with less liability to subsequent disarrangement incident to violent concussions or other accidents.

The indicator mechanism of my lock is so arranged as to indicate what key had been last used to lock it.

A leading feature of my improvement consists of a peculiarly-formed double-bitted key, which, in association with the peculiar crossier-shaped tablets and deeply-notched positively-moved dog, secures absolute accuracy and stability of registration in respect to the key last used to lock it.

While, in respect to some of its features, my invention may be regarded as an improved and simplified form of the indicator-lock described in Reissue No. 9,300, it is in other respects radically different. For example, its construction is purposely such as to make it impossible to put the lock in condition for closure of the shackle by the use of a "master-key" such as described in said reissue, because the key cannot complete its movement without depressing the pawl or dog, and this cannot be effected without registration of the tablets, nor can the key be withdrawn until the complete resetting of the indicator-tablets and the closure of the shackle, which a master-key working independently of the registering mechanism could not do. The means by which these objects are attained and other devices subsid-

iary thereto will be found explained in the sequel.

In the accompanying drawings, Figure 1 is a front view of a lock embodying my improvements, the lock being shown in its locked condition and with the cap removed. Fig. 2 is a front view of the indicating-tablets and the dog in their retracted conditions, the latch-arm being shown in section and in the released condition. Figs. 3 and 4 are bottom views of the lock in its registered and unregistered conditions, respectively. Fig. 5 is a front view of the lock with the inserted key and with the tumbler retracted, so as to imprison the key. Fig. 6 may represent one of the operating-keys. Fig. 7 represents the indicator-tablets, and Fig. 8 the rear tumbler. Fig. 9 represents the case or shell, and Fig. 10 the cap of a secret fastened cap-lock. Fig. 11 is a front view of the same with the cap in position. In Figs. 10 and 11 a portion of the cap is broken away to expose the fastening-screw.

I will premise by describing a lock mechanism proper with which my indicator mechanism is preferably associated.

A may represent the case or shell of a padlock whose shackle is preferably a rigid projection from the case, and consists of a standard, B, whose lateral tongue C has on one side of it, near its rear extremity, a cavity, *c*, whose terminal lip *c'* extends about half-way up, so as to leave at its upper part a gate or opening, *c''*.

Attached to case A by hinge *d* is an arm, D, whose cavity *d'* receives the extremity of the rigid shackle B C. The arm D is tubular, and contains a sliding dog, E, whose tusk *e* is capable, when said dog is in its most protracted position, of traversing the gate *c''*, and in its most retracted condition of engaging behind the lip *c'*, so as to prevent the release of the shackle when the device is locked. That part of the dog E which extends into the lock-case has a claw, *e'*, whose impact with the customary bit, *x*, which is the same on every key of the set or series, of which X may represent one particular key—say key No. 50—in the act of unlocking, causes, first, the protraction of the dog until tusk *e* is opposite gate

c'' , and, secondly, enables the key, in its continued rotation, to swing the arm and its inclined dog clear away from the shackle, so as to free the latter by a strictly direct and positive operation of the key without the necessity of a shackle-spring. A stud, e'' , on dog E occupies gates f and g in a pair of tumblers, F and G, which vibrate upon a pin, H, that projects from the lock-case. Except at the instant of being pushed back by the action of the customary bit, x , on the key X, said tumblers are held to their normal or locked positions by springs f' and g' . An extension, g'' , on tumbler G serves, when the tumbler is pushed back by the key, to imprison the latter within the lock, so as to make its withdrawal impossible until the closure of the lock. When left at liberty the inclined spur g''' on tumbler G operates on stud e'' to draw back the dog into engagement with the shackle.

The registering or indicating mechanism is as follows: I employ two or more segment racks or tablets, J J', which vibrate upon stud K, and whose peripheries are marked each with a series of equidistant numerals or other symbols—as, for example, the consecutive digits from 0 to 9, inclusive. The peripheries of said tablets and the adjacent bottom of the lock-case are cylindrical segments concentric with stud K. An oblong window, a , in said case-bottom enables whatever numbers are placed opposite the opening to be observed. The concave portions of the tablets have deep radial notches j , which correspond in number and circumferential position with the numerals on the convex portions. The arm j' of each tablet has a crosier-shaped hook or return portion, j'' , so as to form a yoke, $j' j''$, between which the supplementary or tablet-operating wards $l' l''$ of the key-bits L L' fit and play snugly, so as to secure an accurate and positive motion of the tablets. The bits L L' are curved to correspond with an arc concentric with the center of vibration of the tablets at the distance of the pin or stud Z, upon which the key vibrates. The opposing surfaces of the tablet-yokes have the convex contour shown.

M is a pawl or tablet-dog (whose thickness equals the aggregate thickness of the tablets) restricted to a vertical path, radial with respect to the tablet-racks, by stumps Q, and has a stud, m , which, engaging in the L-formed slot g'''' of the tumbler G, is thereby held by the latter to proper engagement with said racks. Said pawl is preferably retracted by the same spring, N, that serves to retract the tablets, and is at the proper moment forced into mesh with the latter by positive action of the key, the curved peripheries of whose bits are prolonged sufficiently to hold down the pawl while the lock is being locked, and until assumption of control of the pawl by the tumblers G and release of the key therefrom enable the withdrawal of the latter. The pre-

cise and positive movements of the parts enable the pawl-teeth and corresponding tablet-notches to be formed by the represented deep radial indentations, which form, in conjunction with the immobility of the sprung tumbler-detent G, holds the tablets immovably to the position at which they have been placed by the key last in use, and renders impossible any disturbance or disarrangement of registration (so as to cause it to "lie") to which those indicator-locks have been subject, which depend for dogging the tablets on the force of a spring, when such locks are, by accident or design, subjected to a sudden blow or concussion.

Inasmuch as the necessarily nice and somewhat complex structure of my indicator-lock, and the importance of its efficient action, require occasional inspection, cleansing, repair, lubrication, &c., and inasmuch as the nature of its use requires it to be absolutely inseparable when locked, I have devised a secret fastened cap, R, capable of being used with indicator-locks, dovetail projections S on which engage in corresponding mortises, T, in the shell. Perforated flanges U V on cap and shell receive a screw, W, by which removal of the cap is made impossible when the lock is closed.

I claim as new and of my invention—

1. In an indicator-lock, one or more crosier-formed tablets, J, whose yokes $j' j''$ embrace on both edges any one of the appropriate series of described double-bitted keys X, employed to open and close the lock, said tablets being pivoted on a stud, K, with which the inscribed peripheries of the tablets and the perforated bottom of the lock-case are concentric, in combination with the spring-retracted and key-protracted dog M, which, on the return of the parts to the locked condition, is held in mesh with the tablet-racks by the action of slotted tumbler upon stud m of said dog, substantially as and for the purpose set forth.

2. In an indicator-lock, the crosier-shaped positively-actuated tablet-racks J, vibrating upon a stud, K, concentric with said racks, and with the curved and perforated bottom of the lock-case, in combination with the double-bitted key X, whose duplex supplementary bits L L' fit the yokes $j' j''$ of said tablet-racks, substantially as set forth.

3. In an indicator-lock, the combination of the rigid shackle B C, having the cavity e , the terminal lip e' , and the gate e'' , the tubular hinged arm D, having the opening d for the extremity of said shackle, and the sliding dog E within said arm, whose outer end has the tusk e for engagement with the shackle, and whose inner end has the claw e' for engagement with the bit proper, x , of the key X, substantially as and for the purposes set forth.

4. In an indicator-lock, the separable cap R, whose dovetailed projections S, from its rear side, engage in corresponding mortises, T, in the shell, and whose perforated flange U is

fastened to a flange, V, on the interior of the shell by a secret fastening-screw, W, accessible only when the lock is unlocked, as and for the purpose set forth.

5 5. In an indicator-lock, the combination, with the key X, whose bit proper, *x*, operates on the tumbler G, and shackle-dog E, and whose supplementary bits *l* *l'* operate on the indicator-tablets J, of the projection *g* from said tumbler

G, by which the key is detained within the lock until the setting of the tablets and the closure of the lock, in the manner set forth.

In testimony of which invention I hereunto set my hand.

PHILIP YOE.

Attest:

GEO. H. KNIGHT,
SAML. S. CARPENTER.