

April 19, 1932.

F. L. MILLS

1,854,479

COIN OPERATED MACHINE

Filed March 5, 1929

4 Sheets-Sheet 2

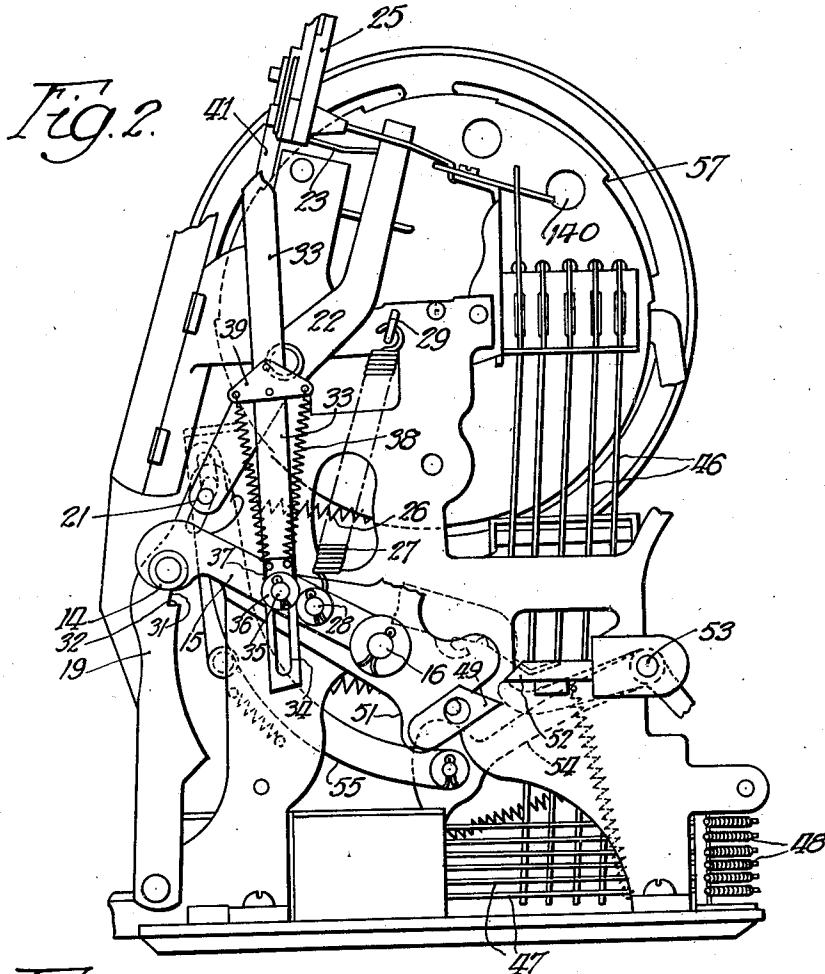
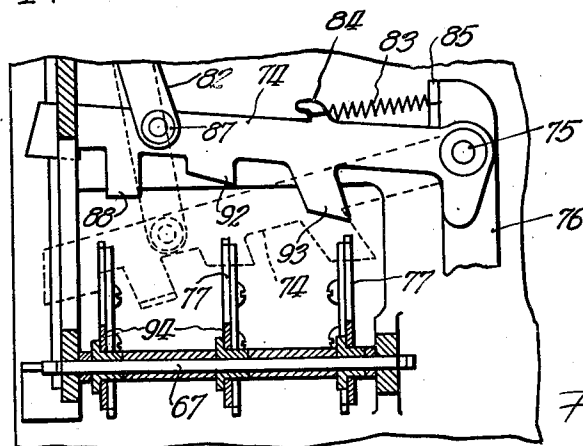

Fig. 4.



Inventor.
Fred L. Mills

April 19, 1932.

F. L. MILLS

1,854,479

COIN OPERATED MACHINE

Filed March 5, 1929

4 Sheets-Sheet 3

Fig. 3.

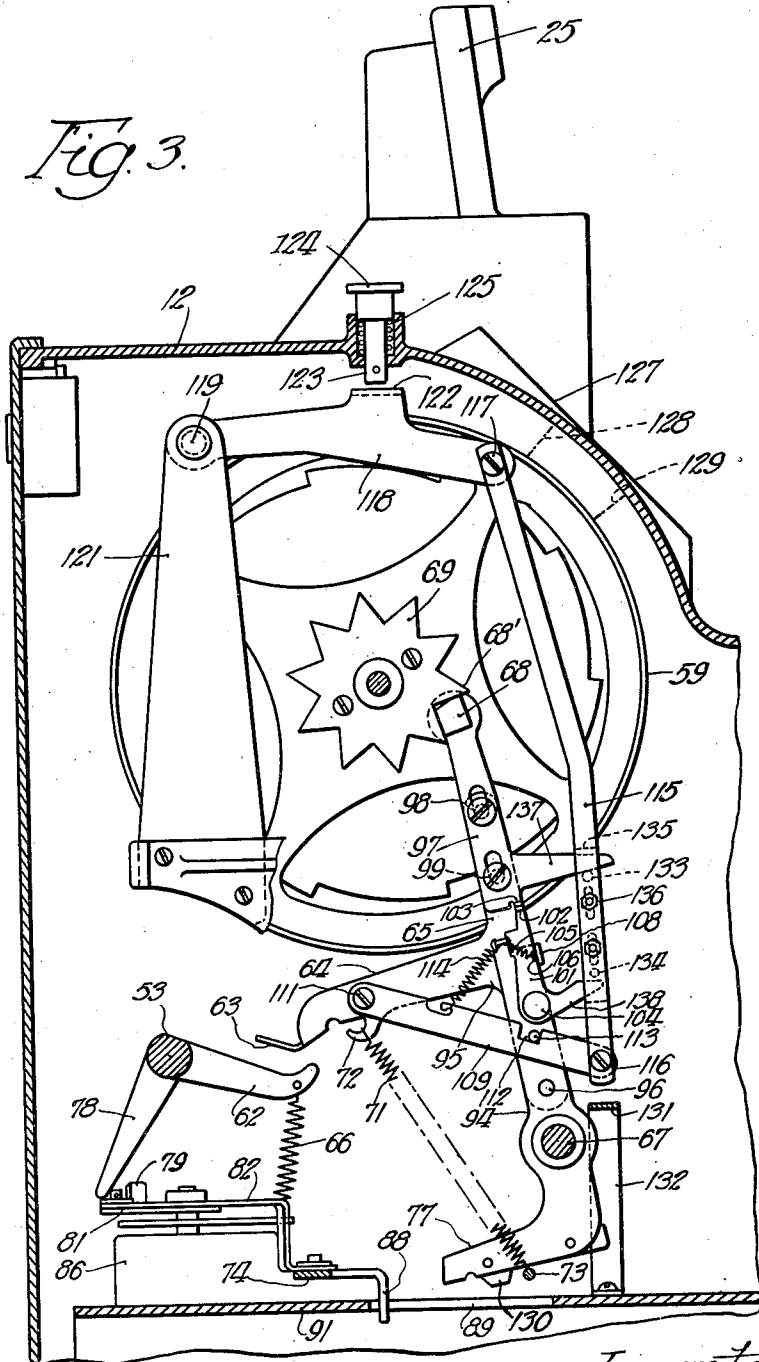

Inventor:
Fred L. Mills

UNITED STATES PATENT OFFICE

FRED L. MILLS, OF OAK PARK, ILLINOIS, ASSIGNOR TO MILLS NOVELTY COMPANY, OF CHICAGO, ILLINOIS, A CORPORATION OF ILLINOIS

COIN-OPERATED MACHINE

Application filed March 5, 1929. Serial No. 344,120.

This invention relates to coin-operated machines of the type in which a plurality of rotatable reels are employed in conjunction with dispensing mechanism controlled by the reels for delivering articles from the machine, the invention having particular reference to the stop mechanism of such a machine. In machines of this character, stop levers are employed for arresting the motion of the reels after predetermined rotation thereof and it has been proposed to employ, in conjunction with said stop levers which ordinarily operate automatically, at predetermined stages in the cycle of operations, skill control devices whereby the operator may cause said levers to operate in advance of the time for the automatic stop, thus enabling him to have some control over the final position of the reels according to the skill which is exercised in manipulating said devices. It has also been proposed to provide means in the machine for compelling the operator to use said skill control devices in order to produce operation of the dispensing mechanism, and in the invention of my Patent #1,805,837, mechanism was provided for stopping the reels in neutral or ineffective position in the event that the skill devices were not operated. The present invention is directed to a new mechanism for the last mentioned purpose. For the interrelationship between the reels and dispensing mechanism reference is made to Patent #1,697,537.

Other objects and advantages of the invention will be apparent as it is better understood from the following description which, taken in connection with the accompanying drawings, discloses a preferred embodiment thereof.

Referring to the drawings,

Fig. 1 is a front elevation of a machine in which my invention is embodied, the casing being removed and certain parts broken away for convention in illustration;

Fig. 2 is a side elevation thereof, taken from the right in Fig. 1;

Fig. 3 is a vertical sectional view, taken through the machine from front to back;

Fig. 4 is a plan view of the clock arm and

associated mechanism for controlling certain operations of the machine; and

Figs. 5 and 6 are detailed views showing different stages in the operation of the stop levers and the skill control devices.

The general construction of the machine is quite well known in the art. Referring first to Fig. 1, the usual operating lever 11 is mounted on the interior of a casing 12 and is adapted to be actuated by a hand lever or crank (not shown) disposed on the exterior of the casing and suitably connected with said operating lever. Said operating lever is provided with a lug 13 adapted to engage a projection 14 on a lever 15 pivotally secured at 16 (see Fig. 2) to a frame upright 17 (shown in Fig. 1), said lever being equipped with a laterally projecting lug 18 on the opposite side thereof from the projection 14, as clearly shown in said Fig. 1. The lug 18 normally engages the upper part of a lever 19 (Fig. 2) which has a pin and slot connection at 21 to intermediately pivoted lever 22, the upper end of which is provided with a pin 23 adapted to enter a coin slot 24 in a coin slot bracket 25 at the top of the machine. The upper end of the lever 19 is connected by a spring 26 with the frame and is thus held in engagement with a lug 18 on the actuating lever 15, said lever being normally held in raised position by means of a spring 27 connected at one end to said lever as indicated at 28 and at the other end to a fixed point on the frame, as indicated at 29.

Said lever 19 is curved outwardly from the point of normal engagement with the lug 18, as shown at 31 in Fig. 2, and is provided with a shoulder 32 just beneath the curved portion 31. Downward movement of the lever 15 produced by actuation of the crank on the outside of the casing permits the lever 19 to be drawn inwardly by means of the spring 26, provided there is no coin in the coin slot, and the downward movement of the lever 15 may continue only until the lug 18 engages the shoulder 32 on the lever 19. The inward movement of said lever 19 is accompanied by a pivotal movement of the lever 22, the pin 23 on said lever 22 being adapted to pass forwardly through the coin slot during this ac-

tion. If there be a coin in the slot, however, it obstructs the movement of said pin 23, holding the same and the levers 22 and 19 in the position shown in Fig. 2, and the lever 15 may then be moved downwardly past the shoulder 32, which will be cleared since the lever 19 is held in the outer position in the manner above described.

The lever 15 is connected with a link 33 which has a slot 34 at the lower end thereof within which is disposed a pin 35 which projects from the lever 15 and has thereon a washer 36 serving to hold the link 33 upon the pin 35, said pin also carrying a clip 37 which is connected by springs 38 with a clip 39 secured to an intermediate part of the link 33, thereby providing a yielding connection between the lever 15 and the link 33.

The upper end of the link 33 is turned, as indicated at 41, and is connected with a lever 42 which has a rearwardly turned end part 41' disposed in the slot 24 and adapted when moved downwardly to engage the coin which rests upon a yieldable support in the slot, downward movement of said lever 42 serving to force said coin through the slot.

A coin chute 43 is provided to receive the coins and direct them to a suitable coin box (not shown), and the machine is or may be also equipped with a tube or magazine 44 for receiving annular checks or tokens, the machine being adapted for operation by such checks or tokens as well as by coins.

The tube or magazine 44 leads to a series of delivery slides 45 which are adapted to be controlled by means of a series of actuating levers 46 (Fig. 2) which serve to actuate associated stop members 47 against the tension of springs 48 by which they are adapted to be actuated when released, this construction being well known and illustrated, for example, in my Patent #1,767,603.

If there be a coin in the slot when the machine is actuated, the lever 15, as previously stated, may be moved downwardly beyond the shoulder 32, and when so moved, an actuating pawl 49 (see Fig. 2) carried upon a member 51, which is rigid with the lever 15, engages an arm 52 which is carried upon a rock shaft 53 which serves to actuate the various instrumentalities of the machine. Said rock shaft 53 carries an arm 54 which is connected with an actuating pawl 55 which has a hook 56 at the upper end thereof adapted, when moved by the rotation of the shaft 53 as just described, to engage shoulders 57 on a series of disks 58 which are carried on a series of concentric shafts indicated generally at 60. Each of said shafts carries a reel 59, of which three are shown in the drawings, there being one of said reels and one of said disks 58 upon each shaft and the shafts being suitably bearinged in the upright 17 and an upright 61 at the opposite side of the machine.

After being rotated by means of the actu-

ating pawl 49, the rock shaft 53 and the actuating members carried thereby are adapted to be returned to normal position by spring means to be presently described, the return movement being through a quick snap action, which causes the pawl 55 to exert a quick jerk upon the disks 58, thereby starting rotation of the same and the reels 59.

The rock shaft 53 also carries a plurality of actuating cams 62, which, when raised by rotation of the rock shaft, are adapted to engage lips 63 upon laterally projecting arms 64 of stop levers 65 (which are clearly shown in Fig. 3), one of said stop levers being provided for each of the reels 59. Springs 66 connecting the cam members 62 with fixed points on the frame tend to draw said members 62 downwardly, thus serving to return the rock shaft 53 to normal position after actuation. Said stop levers 65, the construction of which will be presently described in detail, are pivoted on a fixed shaft 67, and as they are of duplicate construction, they will be described in the singular. A stop lug 68 is carried at the upper end of the lever 65 and is adapted to engage the teeth 68' of a star wheel 69 attached to the reel 59. A spring 71 connected at its upper end to a projection 72 on the arm 64 and at its lower end to a fixed rod 73, tends to hold said stop lever in the position shown in Fig. 3, with the stop lug 68 in engagement with the star wheel 69, thus holding the reel stationary.

Upon actuation of the rock shaft 53, the cam members 62 acting upon the arms 64 of the stop lever, causes the latter to turn on its pivot to the position shown in dotted lines in Fig. 5. At the same time, a clock arm 74, which is horizontally disposed in the lower part of the machine and pivoted at 75 to a fixed frame part 76 (see Fig. 4), is moved toward the right, viewing Figs. 3, 5 and 6, and is thus positioned beneath an angular extension 77 at the lower end of the stop lever 65 below the pivot 67 of the latter. Said clock arm is moved to the position just mentioned by means of an actuating arm 78 carried by the rock shaft 53 and adapted to engage a lug 79 on a horizontally pivoted lever 81 which is connected by an offset link 82 with said clock arm 74. After being moved forwardly to the dotted line position shown in Fig. 4, said arm is slowly returned to the full line position shown in said Fig. 4 by means of a spring 83 which is connected at one end to a hook 84 on the arm 74 and at the opposite end to a lug 85 on the frame part 76, the return movement being governed by means of a clock mechanism (not shown), the gearing of which is disposed within a housing 86. The link 82 is pivotally connected at 87 to said clock arm or bar 74, and said bar has a guide lug 88 extending forwardly therefrom and turned downwardly, the lower part thereof being disposed within a slot 89 in a floor

plate 91. There are only two other forwardly extending lugs 92 and 93 on said clock arm adapted respectively to be engaged by extensions 77 on the second and third stop levers 65, the construction and operation of the clock arm being such as to cause the stop lever at the left of Fig. 4 to first drop off said arm, thus permitting the stop lever to be drawn into engagement with the star wheel 69 by means of the spring 71, the middle member being next released for like action, which is followed by release of the third stop lever so that the reels, beginning with the one at the left in Fig. 1, are successively stopped automatically if they are not first manually stopped by means of skill control devices which will now be described.

Referring to Fig. 3, it will be noted that the stop lever 65 consists of a member 94 which is the part pivoted to shaft 67, a member 95, pivotally connected at 96 to member 94, and another part or section 97 which is secured to the part 95 by pin and slot connections as indicated at 98 and 99. It is the part 97 which carries the stop lug 68 adapted to engage the star wheel 69.

The member 97 is normally held in projected position by means of a bellcrank 101 which has flange 102 at the upper end thereof, adapted to engage a flange 103 on the member 97. The bellcrank 101 is pivoted at 104 to the lower member or section 94 of the stop lever and is normally held in the position shown in Fig. 3 by means of a spring 105 connected at one end to a lug 106 on the upper arm of said bellcrank 101 and at the opposite end to a lug 107 on the upper end of the member 94.

A lug 108 is provided on the member 94 and is normally engaged by the member 95, the members 94 and 95 being normally held in the relationship shown in Fig. 3 by means of a lock bar 109 pivoted at 111 to the arm 64 on the member 95 and having a notch 112 adapted to receive a pin 113 on the member 94. Said bar is normally held in locked position by means of a spring 114 connecting the same with the lug 107 on the upper end of the member 94. When thus connected, the entire stop lever assembly is adapted to act as a unit and will operate automatically to stop the reels when the extensions 77 drop off the clock arm 74.

Provision is made, however, to enable the operator to cause said stop levers to operate in advance of the time for the automatic stop through the exercise of skill. A link 115 is connected at 116 with lock bar 109 and the upper end of said link is connected at 117 with an arm 118 pivoted at 119 to a frame upright 121. The arms 118 have horizontal flange portions 122 (see Fig. 1) disposed above the reels 59 and are adapted to be depressed by means of plungers 123 having a finger piece or button 124 secured to the up-

per end thereof. Said plungers are normally held in outer position by springs 126 and are adapted to be depressed by the operator, it being understood that there is a separate plunger for each reel.

The reels have a series of symbols or legends 126 on their peripheries, and limited sectors of the reels are visible through windows provided in the upper front part 127 of the machine casing 12. The width of the window opening is indicated by dotted lines at 128 and 129 in Fig. 3. By watching these symbols as the reels rotate and by operating the plungers 123 with precision, the operator may control the stopping of the reels by releasing the stop levers in a manner which will next be described.

It will be noted that there are lugs 130 on the lower parts of the extensions 77 on the stop levers which hold the latter in the dotted line position shown in Fig. 5 until said lugs are freed from the clock arm 74 during the receding motion of the latter. Until said lug 130 drops off said clock arm, the stop lever is held in position so that the lower end of the link 115 is too close to a cross piece 131 separated from the floor plate by uprights 132 to permit sufficient depression of said link 115 to remove the lock bar from engagement with the pin 113. When, however, said lug 130 drops off the clock arm 74, the stop lever assembly moves forwardly to a limited extent and the operator may then, by depressing the plungers 123, disengage the lock bar 109 from the pin 113, which permits the section 95 of the stop lever to be actuated by the spring 71, thereby moving the stop lug 68 into engagement with the star wheel 69, as shown in full lines in Fig. 5.

Pins 133 and 134 are provided on the link 115, which has a bar 135 adjustably secured thereto, as indicated at 136. An extension 137 is provided on the lever section or member 97, and the end thereof is disposed above the pin 133. Lower arm 138 of the bellcrank 101 is disposed beneath the pin 134. It will now be apparent that downward movement of the link 115 will be accompanied by a turning of the bellcrank 101 on the pivot 104 from the position shown in Fig. 3 to that shown in Fig. 5, and that the lever section or member 97 will move downwardly on the member 95 by gravity, thus shortening the length of the lever. This results in a different point of engagement between the stop lever and the star wheel or stop member 69 on the reel, so that the reel will be stopped in a different series of positions when the skill devices are operated than when the stop levers operate automatically upon failure to utilize said skill devices. This means that different sectors of the reels will be visible through the windows in the casing, and the arrangement is preferably such that the symbols will appear in said window only in the event that the skill devices

are operated. Otherwise, blanks will appear and furthermore since the position of the reels 59 and the discs 58, which are provided with openings 140 (Fig. 2) cooperating with the levers 46, controls the operation of the delivery slides 45, the latter may thus be prevented from operating except when the reels are stopped in position with the symbols displayed through the window openings in member 127, which, as explained, can be accomplished only through operation of the manual skill devices.

After the parts have assumed the position shown in full lines in Fig. 5, the next action is for the extension 77 of the stop lever to drop off the clock arm 74, the parts then assuming the position shown in Fig. 6. It will be observed that in this position the notch 112 in the member 109 is immediately beneath the pin 113, and when the stop lever is disengaged from the star wheel 69 upon the next actuation of the machine, the movable member or section 97 of said lever will be again extended through the action of the spring 114 which raises the lock bar 109 and therewith the link 115, which through the action of the pin 133 on the arm 137 of said member 97 extends the latter to normal position, after which the cycle of operations will be repeated.

It is thought that the invention and many of its attendant advantages will be understood from the foregoing description, and it will be apparent that various changes may be made in the form, construction, and arrangement of the parts without departing from the spirit or scope of the invention, or sacrificing all of its material advantages, the form hereinbefore described being merely a preferred embodiment thereof.

I claim:

1. A coin-operated machine comprising a plurality of rotatable reels, dispensing mechanism controlled by said reels, means for setting the reels in motion, and devices for stopping said reels, comprising stop members on the reels, stop levers adapted to engage said members to stop said reels, said levers consisting of sections which are relatively movable whereby the levers may be lengthened or shortened, means for controlling said levers to cause the same to automatically stop the reels, and skill control devices whereby the operator may cause said levers to stop the reels in advance of the time for the automatic stop, operation of said skill devices changing the length of said levers and the point of engagement with the stop members, said reels being thus adapted to be stopped in one series of positions when said levers act automatically and in a different series of positions when said levers are operated through said skill devices, the former positions being ineffective and the latter effective to actuate said dispensing mechanism.

2. A coin-operated machine comprising a

plurality of rotatable reels, dispensing mechanism controlled by said reels, means for setting the reels in motion, and devices for stopping said reels, comprising stop members on the reels, stop levers adapted to engage said members to stop said reels, said levers being split and having one portion thereof mounted on the other with a pin and slot connection, means for controlling said levers to cause the same to automatically stop the reels, and skill control devices whereby the stop levers may be caused to operate in advance of the time for the automatic stop of the reels, operation of said devices producing relative movement of the pin-and-slot-connected portions of the levers and changing the point of engagement of the latter with said stop members whereby the reels are stopped in a different series of positions when the skill devices are operated than when the levers operate automatically.

3. A coin-operated machine comprising a plurality of rotatable reels, dispensing mechanism controlled by said reels, means for setting the reels in motion, and devices for stopping said reels, comprising stop members on the reels, stop levers adapted to engage said members to stop said reels, said levers being split and having one portion thereof mounted on the other with a pin and slot connection, means for controlling said levers to cause the same to automatically stop the reels, and skill control devices whereby the stop levers may be caused to operate in advance of the time for the automatic stop of the reels, operation of said devices producing relative movement of the pin-and-slot-connected portions of the levers and changing the point of engagement of the latter with said stop members whereby the reels are stopped in a different series of positions when the skill devices are operated than when the levers operate automatically, the reels causing operation of said dispensing mechanism only in the series of positions at which they are stopped by operation of said skill devices.

4. A coin-operated machine comprising a plurality of rotatable reels, dispensing mechanism controlled by said reels, means for setting the reels in motion, and devices for stopping said reels, comprising stop members on the reels, stop levers adapted to engage said members to stop said reels, said levers being formed in sections and the section thereof adapted to engage said stop members being slidably mounted upon another section, means for controlling said levers to cause the same to automatically stop the reels after predetermined rotation of the latter, and skill devices for causing operation of said levers in advance of the time for the automatic operation thereof, operation of said skill devices moving said movable sections of the levers to cause the same to stop the reels in a different series of positions than those in which

they are stopped by automatic operation of the levers.

those at which they are stopped when the skill devices are not operated.

5 5. The coin-operated machine comprising a plurality of rotatable reels, dispensing mechanism controlled by said reels, means for setting the reels in motion, and devices for stopping said reels, comprising stop members on the reels, stop levers adapted to engage said members to stop said reels, said levers formed in sections and the section thereof adapted to engage said stop members being slidably mounted upon another section, means for holding said movable section normally projected, means for controlling said levers to cause the same to automatically stop the reels after predetermined rotation of the latter, and skill devices for causing operation of said levers in advance of the time for the automatic operation thereof, operation of said skill devices retracting said movable sections of the levers to cause the same to stop the reels in a different series of positions than those in which they are stopped by automatic operation of the levers.

8. A coin-operated machine comprising a plurality of rotatable reels, means for setting said reels in motion and devices for arresting the motion of said reels, comprising stop members on the reels, stop levers adapted to engage said members to stop the reels, said levers being adjustable in length, means for controlling said levers to cause the same to automatically stop the reels after predetermined rotation of the latter, skill devices whereby earlier stopping of the reels may be effected, operation of said devices adjusting the length of the levers whereby the reels are stopped in a different series of positions when said levers are caused to operate through actuation of said skill devices than those at which they are stopped when the skill devices are not operated, and a casing in which said reels are mounted, said casing having a window through which small sectors of the reels are visible, said reels bearing a series of symbols about their peripheries and said symbols being visible only when the reels are in one of the positions at which they are stopped by operation of said skill devices.

25 6. A coin-operated machine comprising a plurality of rotatable reels, dispensing mechanism controlled by said reels, means for setting the reels in motion, and devices for stopping said reels, comprising stop members on the reels, stop levers adapted to engage said members to stop said reels, said levers being formed in sections and the section thereof adapted to engage said stop members being slidably mounted upon another section, means for holding said movable section normally projected, means for controlling said levers to cause the same to automatically stop the reels after predetermined rotation of the latter, skill devices for causing operation of said levers in advance of the time for the automatic operation thereof, operation of said skill devices retracting said movable sections of the levers to cause the same to stop the reels in a different series of positions than those in which they are stopped by automatic operation of the levers, and means for projecting said movable section of the levers upon each operation of the machine.

9. A coin-operated machine comprising a plurality of rotatable reels, means for setting said reels in motion and devices for arresting the motion of said reels, comprising stop members on the reels, stop levers adapted to engage said members to stop the reels, said levers being adjustable in length, means for controlling said levers to cause the same to automatically stop the reels after predetermined rotation of the latter, skill devices whereby earlier stopping of the reels may be effected, operation of said devices adjusting the length of the levers whereby the reels are stopped in a different series of positions when said levers are caused to operate through actuation of said skill devices than those at which they are stopped when the skill devices are not operated, and a dispensing mechanism controlled according to the position of rest of said reels and being operable only when the reels are in one of the positions in which they are stopped by operation of said skill devices.

50 7. A coin-operated machine comprising a plurality of rotatable reels, means for setting said reels in motion and devices for arresting the motion of said reels, comprising stop members on the reels, stop levers adapted to engage said members to stop the reels, said levers being adjustable in length, means for controlling said levers to cause the same to automatically stop the reels after predetermined rotation of the later, and skill devices whereby earlier stopping of the reels may be effected, operation of said devices adjusting the length of the levers whereby the reels are stopped in a different series of positions when said levers are caused to operate through actuation of said skill devices than

10. A coin-operated machine comprising a plurality of rotatable reels, means for setting said reels in motion and devices for arresting the motion of said reels, comprising stop members on the reels, stop levers adapted to engage said members to stop the reels, said levers being adjustable in length, means for controlling said levers to cause the same to automatically stop the reels after predetermined rotation of the latter, skill devices whereby earlier stopping of the reels may be effected, operation of said devices adjusting the length of the levers whereby the reels are stopped in a different series of positions when said levers are caused to operate through

actuation of said skill devices than those at which they are stopped when the skill devices are not operated, a dispensing mechanism controlled according to the position of rest of
5 said reels and being operable only when the reels are in one of the positions in which they are stopped by operation of said skill devices, and a casing in which said reels are mounted, said casing having a win-
10 dow through which small sectors of the reels are visible, said reels bearing a series of symbols about their peripheries, said symbols being visible only when the reels are stopped in position to cause operation of said dispensing mechanism.
15

11. A coin-operated machine comprising a plurality of rotatable reels provided with toothed wheels, means for setting said reels in motion, stop mechanism including levers
20 movable into engagement with said toothed wheels to stop the same during the normal cycle of operations of the machine, and devices under the control of the operator for causing actuation of said levers prior to the
25 time for normal operation thereof, the lengths of said levers being adjustable through the operation of said devices to change the points of engagement of said levers with the teeth of said wheels, thereby stopping the reels
30 in different positions than those in which they would be stopped by normal operation of said levers.

In witness whereof, I hereunto subscribe my name to this specification.

35

FRED L. MILLS.

40

45

50

55

60

65